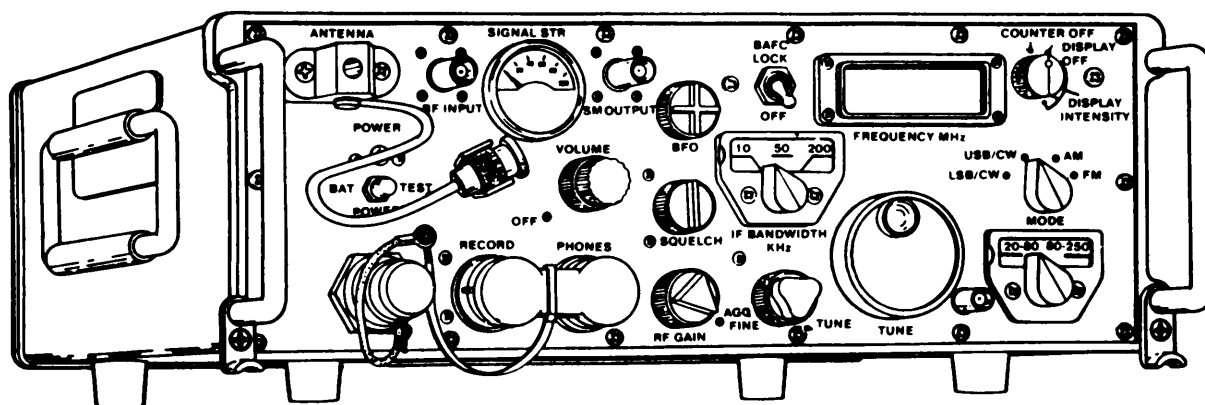

TECHNICAL MANUAL

OPERATOR'S, ORGANIZATIONAL, DIRECT SUPPORT AND GENERAL SUPPORT MAINTENANCE MANUAL



RECEIVER R-2200/GRR-8(V) (NSN 5895-01-060-6492)

Distribution authorized to the Department of Defense and DOD contractors only for official use or for administration or operational purposes. This determination was made on 11 January 1988. Other requests for this document will be referred to Commander, US Army Communications Electronics Command and Fort Monmouth, ATTN: AMSEL-ME-P, Port Monmouth, NJ 07703-5000.

DESTRUCTION NOTICE - Destroy by any method that will prevent disclosure of contents or reconstruction of the document.

Courtesy of <http://BlackRadios.terryo.org>

CHANGE

No. 1

HEADQUARTERS
DEPARTMENT OF THE ARMY
Washington, DC, 1 July 1989

OPERATOR'S, ORGANIZATIONAL,
DIRECT SUPPORT AND GENERAL SUPPORT
MAINTENANCE MANUAL

RECEIVER R-2200/GRR-8(V)
(NSN 5895-01-060-6492)

TM 11-5895-1227-14-1, September 1984, is changed as follows:

1. Remove old pages and insert new pages as indicated below. New or changed material is indicated by a vertical bar in the margin of the page. Added or revised illustrations are indicated by a vertical bar adjacent to the identification number.

Remove pages

Insert pages

| | |
|-----------------------------|-------------------------|
| A/(B blank) | A and B |
| i through vi | ...i through vi |
| 0-1 and 0-2 | ..0-1 and 0-2 |
| 0-3 and 1-0 | 0-3 and 1-0 |
| 3-5 and 3-6 | ..3-5 and 3-6 |
| 4-21/(4-22 blank) | ..4-21/(4-22 blank) |
| 4-37 and 4-38 | ..4-37 and 4-38 |
| 5-33 and 5-34 | ..5-32.1 through 5-34 |
| None | ..6-16.1/(6-16.2 blank) |

2. File this change sheet in the front of the publication for reference purposes.

Distribution authorized to the Department of Defense and DOD contractors only for official use or for administration or operational purposes. This determination was made on 7 March 1989. Other request for this document will be referred to Commander, US Army Communications-Electronics Command and Fort Monmouth, ATTN: AMSEL-LC-ME-P, Fort Monmouth, NJ 07703-5000.

DESTRUCTION NOTICE – Destroy by any method that will prevent disclosure of contents or reconstruction of the document.

By Order of the Secretary of the Army:

Official:

CARL E. VUONO
General, United States Army
Chief of Staff

WILLIAM J. MEEHAN II
Brigadier General, United States Army
The Adjutant General

DISTRIBUTED:

To be distributed in accordance with DA Form 12-51 operator, unit,
and DS/GS requirements for AN/GRR-8.



5

SAFETY STEPS TO FOLLOW IF SOMEONE IS THE VICTIM OF ELECTRICAL SHOCK

1

DO NOT TRY TO PULL OR GRAB THE INDIVIDUAL

2

IF POSSIBLE, TURN OFF THE ELECTRICAL POWER

3

IF YOU CANNOT TURN OFF THE ELECTRICAL POWER, PULL, PUSH, OR LIFT THE PERSON TO SAFETY USING A DRY WOODEN POLE OR A DRY ROPE OR SOME OTHER INSULATING MATERIAL

4

SEND FOR HELP AS SOON AS POSSIBLE

5

AFTER THE INJURED PERSON IS FREE OF CONTACT WITH THE SOURCE OF ELECTRICAL SHOCK, MOVE THE PERSON A SHORT DISTANCE AWAY AND IMMEDIATELY START ARTIFICIAL RESUSCITATION

WARNING

The Receiver uses voltages which may be fatal if contacted. Do not be misled by the term "Low Voltage." Potentials as low as 50 volts may cause death under adverse conditions. Extreme caution should be exercised when working this equipment. Death on contact may result if personnel fail to observe safety precautions

1. Do not work on electronic equipment unless there is another person nearby who is familiar with the operation and hazards of the equipment and who is competent in administering first aid.
2. Whenever possible, turn off the power supply to the equipment before beginning maintenance on the equipment.
3. Do not remove the protective covers to the equipment unless you are authorized to do SO.
4. When technicians are aided by operators, they must be warned about dangerous areas. A periodic review of safety precautions in TB 385-4, Safety precautions For Maintenance of Electrical/Electronic Equipment, is recommended.
5. Seek advice from your supervisor whenever you are in doubt about electrical safety conditions.
6. For Artificial Respiration, refer to FM 21-11.

WARNING

The batteries used in the Receiver are hazardous and may cause serious injury to personnel if safety precautions are not observed.

1. Remove batteries when receiver is not in operation. Leaving batteries in the equipment when it is not in use may result in a leakage or explosion.
2. Do not crush, puncture, disassemble, or otherwise mutilate batteries.
3. Do not attempt to recharge alkaline batteries.
4. Observe extreme caution when recharging nickel cadmium batteries by ensuring proper electrical connections and keeping chargers away from other equipment that may spark and cause explosion.

CAUTION

Extreme caution should be used in reseating the receivers main chassis into its protective case. A problem may be caused by the failure of A9, P1-J6 to properly mate. If this problem is encountered, remove the rear mounted battery cover and reconnect the plug manually.

TECHNICAL MANUAL

NO. 11-5895-1227-14-1

HEADQUARTERS
DEPARTMENT OF THE ARMY
Washington, D.C., 1 May 1988

Operator's, Organizational,
Direct Support, and General Support
Maintenance Manual

RECEIVER R-2200/GRR-8(V)
(NSN 5895-01-060-6492)

REPORTING ERRORS AND RECOMMENDING IMPROVEMENTS

You can help improve this manual. If you find any mistakes or if you know of a way to improve the procedures, please let us know. Mail your letter, DA Form 2028 (Recommended Changes to Publications and Blank Forms), or DA Form 2028-2 located in the back of this manual direct to: Commander, US Army Communications-Electronics Command and Fort Monmouth, ATTN: AMSEL-LC-ME-PS, Fort Monmouth, New Jersey 07703-5000. A reply will be furnished direct to you.

SECTION O
INTRODUCTION

| <u>Paragraph</u> | | <u>Page</u> |
|------------------|---|-------------|
| 0.1 | Scope | 0-1 |
| 0.1.1 | Type of Manual | 0-1 |
| 0.1.2 | Model Numbers and Equipment Names. | 0-1 |
| 0.1.3 | Purpose of Equipment. | 0-1 |
| 0.2 | Consolidated Index of Army Publications and Blank Forms | 0-1 |
| 0.3 | Maintenance Forms, Records and Reports | 0-1 |
| 0.3.1 | Reports of Maintenance and Unsatisfactory Equipment. | 0-1 |
| 0.3.2 | Reporting of Item and Packaging Discrepancies | 0-1 |
| 0.3.3 | Transportation Discrepancy Report (TDR)(SF 361) | 0-1 |
| 0.4 | Destruction of Army Electronics Materiel | 0-1 |
| 0.5 | Administrative Storage. | 0-2 |
| 0.6 | Tools and Test Equipment. | 0-2 |
| 0.7 | Official Nomenclature, Names and Designations. | 0-2 |
| 0.8 | Reporting Equipment Improvement Recommendations | 0-3 |
| 0.9 | Warranty Information. | 0-3 |

SECTION I
GENERAL DESCRIPTION

| <u>Paragraph</u> | | <u>Page</u> |
|------------------|--|-------------|
| 1.1 | Electrical Characteristics | 1-1 |
| 1.2 | Mechanical Characteristics | 1-1 |
| 1.3 | Equipment Supplied | 1-2 |
| 1.4 | Equipment Required But Not Supplied. | 1-2 |

**Section II
INSTALLATION AND OPERATION**

| <u>Paragraph</u> | | <u>Page</u> |
|------------------|---|-------------|
| 2.1 | Unpacking and Inspection | 2-1 |
| 2.2 | Installation and Removal Procedures | 2-1 |
| 2.3 | Operation | 2-4 |
| 2.4 | Preparation for Reshipment. | 2-6 |

**Section III
CIRCUIT DESCRIPTION**

| | | |
|--------|---|------|
| 3.1 | General | 3-1 |
| 3.2 | Functional Description | 3-1 |
| 3.3 | Detailed Circuit Description | 3-3 |
| 3.3.2 | Type 791783 Antenna Switch (A 1). | 3-3 |
| 3.3.3 | Type WJ-9120, WJ-9121, and WJ-9124 Tuner Assemblies (A2). | 3-3 |
| 3.3.4 | Type 791806 Counter Assembly (A3). | 3-4 |
| 3.3.5 | Type 791800-1 IF Demodulator (A4). | 3-6 |
| 3.3.6 | Type 79817 AGC Squelch (A5). | 3-9 |
| 3.3.7 | Type 791794 DC/DC Converter (A6). | 3-11 |
| 3.3.8 | Type 791784 FM Discriminator (A7). | 3-12 |
| 3.3.9 | Type 7464 Audio/Record Amplifier (A8). | 3-13 |
| 3.3.10 | Type 791795-1 D-Cell Insert (A9). | 3-13 |
| 3.3.11 | Type 791809-1 Front Panel Cover With Speaker (A10). | 3-13 |

**Section IV
MAINTENANCE**

| | | |
|--------|---|------|
| 4.1 | General | 4-1 |
| 4.2 | Cleaning and Lubrication | 4-1 |
| 4.3 | Inspection for Damage or Wear | 4-1 |
| 4.4 | Test Equipment Required | 4-1 |
| 4.4.1 | Depot Test Equipment | 4-1 |
| 4.4.2 | Direct Support Test Equipment | 4-2 |
| 4.5 | Troubleshooting Procedures | 4-2 |
| 4.6 | Performance Checks | 4-2 |
| 4.7 | Alignment Procedures | 4-11 |
| 4.8 | Subassembly Removal, Repair and Replacement | 4-19 |
| 4.8.1 | Battery Pack Jack (J6) Removal | 4-19 |
| 4.8.2 | Signal Strength Meter (M1) Removal. | 4-19 |
| 4.8.3 | Battery Test Switch (S6) Removal. | 4-19 |
| 4.8.4 | Battery Check Lamp (CR1) Removal | 4-19 |
| 4.8.5 | Record Control (R11) Removal | 4-19 |
| 4.8.6 | Battery Pack Plug (A9P 1) Removal | 4-20 |
| 4.8.7 | Speaker Cable and Plug (A10P1) Removal | 4-20 |
| 4.8.8 | Speaker (LS1) Removal | 4-20 |
| 4.8.9 | Audio Power Amplifier Board (10A1) Removal | 4-20 |
| 4.8.10 | Display Board (A3A1A1) Removal | 4-20 |
| 4.8.11 | Counter Board (A3A1) Removal | 4-21 |
| 4.8.12 | Wideband Amplifier Board (A3A2) Removal. | 4-21 |

Section V
PARTS LIST

| <u>Paragraph</u> | | <u>Page</u> |
|------------------|------------------------------------|-------------|
| 5.1 | Unit Numbering Method. | 5-1 |
| 5.2 | Reference Designation Prefix. | 5-1 |
| 5.3 | List of Manufacturers. | 5-1 |
| 5.4 | Parts List. | 5-4 |

Section VI
SCHEMATIC DIAGRAMS

APPENDIX A
REFERENCES

APPENDIX B
MAINTENANCE ALLOCATION CHART

APPENDIX C
BASIC ISSUE ITEMS

LIST OF ILLUSTRATIONS

| <u>Figure</u> | | <u>Page</u> |
|---------------|--|-------------|
| 1-1 | Type WJ-8640-1 VHF Portable Receiver. | 1-0 |
| 3-1 | Type WJ-8640-1 Simplified Block Diagram. | 3-0 |
| 4-1 | Test Setup, IF Rejection Circuit. | 4-3 |
| 4-2 | Test Setup, Image Rejection Circuit. | 4-4 |
| 4-3 | Test Setup, IF Bandwidth and Center Frequency Circuit. | 4-5 |
| 4-4 | Test Setup, RF Gain Control Range Circuit. | 4-6 |
| 4-5 | Test Setup, Fine Tuning Range. | 4-8 |
| 4-6 | Test Setup, DC-DC Converter (A6) Alignment. | 4-12 |
| 4-7 | Test Setup, IF Demodulator (A4) Alignment. | 4-13 |
| 4-8 | Test Setup, Product Detector (A4A7) Alignment. | 4-15 |
| 4-9 | Test Setup, Gain Adjustable Amplifier and Diode Switch (A4A3) Alignment. | 4-16 |
| 4-10 | Test Setup, 21.4/10 MHz Converter. Subassembly (A4A1) Alignment. | 4-17 |
| 4-11 | Test Setup, AGC/Squelch (A5) Alignment. | 4-17 |
| 4-12 | Test Setup, FM Discriminator (A7) Alignment. | 4-18 |
| 4-13 | Typical Response, FM Discriminator Output. | 4-19 |
| 5-1 | WJ-8640-1 VHF Portable Receiver, Front. View, Location of Components. | 5-8 |
| 5-2 | WJ-8640-1 VHF Portable Receiver, Rear View, Location of Components. | 5-8 |
| 5-3 | WJ-8640-1 VHF Portable Receiver, Top View, Location of Components. | 5-10 |
| 5-4 | WJ-8640-1 VHF Portable Receiver, Bottom View, Location of Components. | 5-12 |
| 5-5 | Type 791783 Antenna Switch (A1), Location of Components. | 5-14 |
| 5-6 | Type 791806 Counter Assembly (A3), Location of Components. | 5-16 |

LIST OF ILLUSTRATIONS (Continued)

| <u>Figure</u> | | <u>Page</u> |
|---------------|--|-------------|
| 5-7 | Type 791808 Counter Board (A3A1), Location of Components | 5-20 |
| 5-8 | Part 24947 Display Board (A3A1A1), Location of Components | 5-23 |
| 5-9 | Part 34912 Wideband Amplifier and First Counter (A3A2), Location of Components | 5-26 |
| 5-10 | Type 791800-1 IF Demodulator Assembly (A4), Top View, Location of Components | 5-28 |
| 5-11 | Type 791800-1 IF Demodulator Assembly (A4), Bottom View, Location of Components | 5-30 |
| 5-12 | Type 794485 -121.4 to 10 MHz Converter (A4A1), Location of Components | 5-32.1 |
| 5.12.1 | Type 794485 -121.4 to 10 MHz Converter (A4A1) Location of Components | 5-33 |
| 5-13 | Part 24996 BW Control (A4A2), Location of Components | 5-34 |
| 5-14 | Type 791802 Gain Bandwidth Compensation Amplifier (A4A3), Location of Components | 5-36 |
| 5-15 | Type 791803-1 IF Filters and Diode Switches (A4A4), Location of Components | 5-38 |
| 5-16 | Type 791804-1 10 MHz Amplifier (A4A5), Location of Components | 5-39 |
| 5-17 | Type 791790 AM Detector/Buffer (A4A6), Location of Components | 5-41 |
| 5-18 | Type 791785 Product Detector (A4A7), Location of Components | 5-43 |
| 5-19 | Type 791805 LSB/USB Filters (A4A9), Location of Components | 5-44 |
| 5-20 | Type 791817 AGC Squelch (A5), Location of Components | 5-46 |
| 5-21 | Type 791794 DC-DC Converter Board (A6A1), Location of Components | 5-50 |
| 5-22 | Part 24998-1 DC-DC Converter Board (A6A1), Location of Components | 5-52 |
| 5-23 | Type 791784 FM Discriminator Assembly (A7), Location of Components | 5-54 |
| 5-24 | Part 24925 FM Discriminator Board (A7A1), Location of Components | 5-56 |
| 5-25 | Type 7464 Audio and Record Amplifier (A8), Location of Components | 5-59 |
| 5-26 | Type 791795-1 Battery Pack Assembly (A9), Location of Components | 5-60 |
| 5-27 | Type 791792-1 D-Cell Insert Assembly (A9A1), Location of Components | 5-61 |
| 5-28 | Type 791809-1 Front Panel Protective Cover With Speaker (A10), Location of Components | 5-62 |
| 5-29 | Part 24999 Audio Power Amplifier (A10A1), Location of Components | 5-64 |
| 6-1 | Type 791783 Antenna Switch Assembly (A1), Schematic Diagram 24924 | 6-3 |

LIST OF ILLUSTRATIONS (Continued)

| <u>Figure</u> | | <u>Page</u> |
|---------------|--|-------------|
| 6-2 | Type 791806 Counter Module (A3), Schematic Diagram 43636. | 6-5 |
| 6-3 | Type 791808 Counter Module (A3A1), Schematic Diagram 61312 | 6-7 |
| 6-4 | Part 24947 Display Board (A3A1A1), Schematic Diagram 34891 | 6-9 |
| 6-5 | Part 34912 Wideband Amplifier and First Counter (A3A2), Schematic Diagram 43638 | 6-11 |
| 6-6 | Type 791800-1 IF Demodulator (A4), Schematic Diagram 43632 | 6-13 |
| 6-7 | Type 794021 21.4/10 MHz Schematic Diagram 470025. | 6-15 |
| 6-7.1 | Type 794485-1 21.4/10 MHz Converter (A4A1). Schematic Diagram 471060 | 6-16.1 |
| 6-8 | Part 24996 Bandwidth Control (A4A2), Schematic Diagram 34908 | 6-17 |
| 6-9 | Type 791802 Gain BW Compensation Amplifier (A4A3), Schematic Diagram 43635 | 6-19 |
| 6-10 | Type 791803-1 IF Filter and Diode Switches (A4A3), Schematic Diagram 34909 | 6-21 |
| 6-11 | Type 791804-1 10 MHz Amplifier (A4A5, A4A8) Schematic Diagram 24997 | 6-23 |
| 6-12 | Type 791790 AM Detector/Buffer (A4A6), Schematic Diagram 34890 | 6-25 |
| 6-13 | Type 791785 Product Detector (A4A7), Schematic Diagram 43626 | 6-27 |
| 6-14 | Type 791805 LSB/USB Filter (A4A9), Schematic Diagram 34911 | 6-29 |
| 6-15 | Type 791817 AGC Squelch (A5), Schematic Diagram 43645 | 6-31 |
| 6-16 | Type 791794 DC-DC Converter (A6), Schematic Diagram 51264 | 6-33 |
| 6-17 | Type 791784 FM Discriminator (A?), Schematic Diagram 51253 | 6-35 |
| 6-18 | Type 7464 Audio/Record Amplifier (A8), Schematic Diagram 43627 | 6-37 |
| 6-19 | Type 791795-1 D-Cell Insert (A9), Schematic Diagram 24985 | 6-39 |
| 6-20 | Type 791809-1 Front Panel Protective Cover w/Speaker (A10), Schematic Diagram 34913 | 6-41 |
| 6-21 | Type WJ-8640-1 VHF Portable Receiver, Main Chassis, Schematic Diagram | 6-43 |

LIST OF FIGURES

| <u>Figure</u> | | <u>Page</u> |
|---------------|---|-------------|
| 7-1 | Characteristic Curve for Charging of D-Cell Nicad Battery Insert | 7-3 |
| 7-2 | WJ-8640/BC Battery Charger, Location of Components | 7-6 |

LIST OF FIGURES (con't)

| <u>Figure</u> | | <u>Page</u> |
|---------------|--|-------------|
| 7-3 | WJ-8640/BC Battery Charger, Location of Components. | 7-7 |
| 7-4 | Part 24959 Regulator Assembly (A1), Location of Components. | 7-9 |
| 7-5 | WJ-8640/BC Battery Charger Main Chassis, Schematic Diagram | 7-11 |

LIST OF TABLES

| <u>Table</u> | | <u>Page</u> |
|--------------|--|-------------|
| 1-1 | Type WJ-8640-1 Portable Receiver, Specifications | vii |
| 1-2 | Type WJ-8640-1 Sensitivity. | VIII |
| 1-3 | Type WJ-8640-1 Operating Time (in hours). | VIII |
| 4-1 | Type WJ-8640-1 Direct Support Troubleshooting Chart | 4-23 |
| 4-2 | Type WJ-8640-1 Typical Transistor Voltages. | 4-235 |
| 4-3 | Type WJ-8640-1 Typical Integrated Circuit Pin voltages | 4-236 |

Table 1-1. Type WJ-8640-1 Portable Receiver, Specifications

| | |
|---|--|
| Types of Reception | AM, FM, USB/CW, LSB/CW |
| Tuning Head Range: | |
| WJ-9120. | 0.5 to 30 MHz |
| WJ-9121. | 20. to 250 MHz |
| WJ-9124. | 250 to 500 MHz |
| Input Impedance | 50 ohms, nominal, unbalanced |
| Main Tuning Control | Approx. 40 turns from band edge to band edge |
| Fine Tuning Range | 0.05 % of tuned frequency, minimum |
| Noise Figure | See Table 1-2 |
| IF Bandwidths | |
| Standard. | 10 kHz, 50 kHz, 200 kHz |
| Options | 5 kHz, 20 kHz |
| Antenna Conducted LO Radiation | 15 uV, maximum, across 50 ohms |
| Local Oscillator Stability (open Drift) | |
| Drift Due to Shock | Less than 20 PPM |
| Drift Due to Time | Less than 10 PPM per hour, maximum, after one-hour warm-up at constant temperature |
| AM Sensitivity. | See Table 1-2 |
| FM Sensitivity. | See Table 1-2 |
| CW/SSB Sensitivity. | See Table 1-2 |
| Audio Frequency Response | Within 3 dB from 250 to 3000 Hz |
| Audio/Phone Power | 2.5 mw into 500 ohms |
| Record Output: | |
| Frequency Response | Within 3 dB from 20 Hz to 200 Hz |
| Output Level. | 1.0 Vrms across 100 ohms |
| Meter. | Signal Strength |
| Environmental Conditions: | |
| Temperature, Operating. | -20° to +60°C |
| Temperature, Non-Operating | -40° to +70°C |
| Altitude, Operating. | 35,000 feet |
| Altitude, Non-Operating | 50,000 feet |
| Humidity. | 98% (weatherproof construction) |
| Vibration | MIL-STD-810, Method 514, Procedure X |
| Bounce | MIL-STD-810, Method 514, Procedure IX |
| Drop. | MIL-STD-810, Method 516, Procedure II |
| Bench Handling | MIL-STD-810, Method 516, Procedure V |
| Weight | |
| Receiver | 18 lbs., approximately |
| Standard battery pack (with batteries). | 5.5 lbs., approximately |
| Optional battery pack (with NICAD batteries and charger). | 10 lbs.. approximately |

Table 1-1. Type WJ-8640-1 Portable Receiver, Specifications (con't)

Power Requirements Self contained replaceable battery pack accommodates
 10 ea. D-Cell Alkaline 3.5 A/hr.
 10 ea. NICAD Cells (D-Cell size) 3.5 A/hr.
 1 ea. BA-4386 10 A/hr.

Type U318/U Front panel connector provided for vehicle supply (nominal +12 V or +24V)

Power Requirements for Optional Battery Charger with 10 NICAD batteries included 115/220 Vat, 10%, 50-400 Hz

Table 1-2. Sensitivity

| Tuner Noise Figure | Sensitivity in dBm at available IF BW's | | | | |
|--------------------|---|--------|--------|--------|---------|
| | 5 kHz | 10 kHz | 20 kHz | 50 kHz | 200 kHz |
| 5 dB | -113 | -110 | -107 | -103 | -97 |
| 6 dB | -112 | -109 | -106 | -102 | -96 |
| 7 dB | -111 | -108 | -105 | -101 | -95 |
| 8 dB | -110 | -107 | -104 | -100 | -94 |
| 9 dB | -109 | -106 | -103 | -99 | -93 |
| 10 dB | -108 | -105 | -102 | -98 | -92 |
| 11 dB | -107 | -104 | -101 | -97 | -91 |
| 12 dB | -106 | -103 | -100 | -96 | -90 |

Table 1-3. Operating Time On Hours)

| Display ON | | | |
|-------------|---------|---------------------------------------|-------------|
| Supply | 0.5 MHz | 20-250 MHz 20-80 MHz 80-250 MHz | 250-500 MHz |
| BA-4386 | 24 | 40 | 24 |
| Alkaline | 9.6 | 16 | 9.6 |
| NICAD | 10.8 | 18 | 10.8 |
| Display OFF | | | |
| Supply | 0.5 MHz | 20-250 MHz 20-80 MHz 80-250 MHz | 250-500 MHz |
| BA-4386 | 30 | 50 | 30 |
| Alkaline | 13.2 | 22 | 13.2 |
| NICAD | 14.4 | 24 | 14.4 |

SECTION O

INTRODUCTION

0.1 SCOPE

0.1.1 TYPE OF MANUAL. This Operator, Organizational, Direct Support, and General Support Maintenance commercial manual is one of a four-part series of technical manuals for the AN/GRR-8(V) Receiver. This part describes the operation and maintenance of the Radio Receiver while the other three parts describe the TN-586/GRR-8(V) Tuner, TN-584/GRR-8(V) Tuner, and TN-585/GRR-8(V) Tuner, respectively.

0.1.2 MODEL NUMBERS AND EQUIPMENT NAMES. The Receiver, AN/GRR-8(V), is part of the Radio Receiver Direction Finder Set, AN/PRD-11. The other units of this set include the direction finder antenna, AS-3733/PRD-11, and the panoramic indicator, 1P-1355/GRR-8(V). In this manual, the receiver will be referred to as the receiver, manpack receiver or portable receiver, and by its manufacturers model number, WJ-8640-1. A complete cross reference of common equipment names and nomenclatures used in this manual is provided in paragraph 0.7.

0.1.3 PURPOSE OF EQUIPMENT. As part of the radio receiver direction finder set, the receiver tunes in rf signals from the direction finder antenna in the AM, FM and CW modes. It also provides a digital readout of the tuned frequency and provides audio output for a headset, speaker assembly or recorder. The receiver provides an input to the panoramic indicator for a visual waveform display of the tuned frequency and to aid in fine tuning the signal. The receiver also provides an input signal to the df processor for determination of the line of bearing of the tuned signal.

0.2 CONSOLIDATED INDEX OF ARMY PUBLICATIONS AND BLANK FORMS

Refer to the latest issue of DA Pam 25-30 to determine whether there are new editions, changes or additional publications pertaining to the equipment.

0.3 MAINTENANCE FORMS, RECORDS AND REPORTS

0.3.1 REPORTS OF MAINTENANCE AND UNSATISFACTORY EQUIPMENT. Department of the Army forms and procedures used for equipment maintenance will be those prescribed by DA Pam 738-750 as contained in Maintenance Management Update.

0.3.2 REPORTING OF ITEM AND PACKAGING DISCREPANCIES. Fill out and forward SF 364 (Report of Discrepancy (ROD)) as prescribed in AR 735-11-2/DLAR 4140.55/SECNAVINST 4355.18/AFR 400-54/MCO 430.3J.

0.3.3 TRANSPORTATION DISCREPANCY REPORT (TDR) (SF 361). Fill out and forward Transportation Discrepancy Report (TDR) (SF 361) as prescribed in AR 55-38/NAVSUPINST 4610.33C/AFR 75-1 8/MCO P4610.19D/DLAR 4500.15.

0.4 DESTRUCTION OF ARMY ELECTRONICS MATERIEL

Destruction of Army electronics materiel to prevent enemy use shall be in accordance with TM 750-244-2.

0.5 ADMINISTRATIVE STORAGE

Administrative storage of equipment issued to and used by Army activities will have preventive maintenance performed in accordance with the PMCS charts before storing. When removing the equipment from administrative storage the PMCS should be performed to assure operational readiness. Preparation of equipment for shipment or limited storage is covered in paragraph 2.4.

0.6 TOOL AND TEST EQUIPMENT

Refer to the Modified Table of Organization and Equipment (MTOE) applicable to your unit for tools used in the maintenance of the receiver. Test equipment required for troubleshooting and maintenance of the receiver is listed in paragraph 4.4.

0.7 OFFICIAL NOMENCLATURE, NAMES AND DESIGNATIONS

The list below will help you identify the official nomenclature of the major equipment items used with the receiver. It also provides the common name used in the manual when it is different from the official nomenclature. Official nomenclature must be used when completing forms or when looking up technical manuals.

| <u>Common Name</u> | <u>Official Nomenclature</u> |
|---|--|
| D-Cell battery | Battery, BA-30 |
| Battery charger | Battery Charger, WJ-8640/BC |
| Df antenna | Antenna, Direction Finder, AS-3732/PRD-11 |
| | Antenna, Direction Finder, As-3733/PRD-11 |
| Df processor | Control, Processor Display, C-11495/PRD-11 |
| Direction Finder Set | Direction Finder Set, Radio Receiver, AN/PRD-11 |
| Dry cell battery | Battery, Dry, BA-4386/PRC-25 |
| Headset | Headset, Type 994-9913 |
| Lithium battery | Battery, Non-rechargeable Lithium S0 ₂ , BA-5598/U |
| Magnesium battery | Battery, BA-4386 |
| Manpack Receiver, WJ-8640-1, Receiver, Portable Receiver | Receiver, AN/GRR-8(V) |
| Nicad battery | |
| Signal Monitor, WJ-9180-1 | Battery, Storage, BB-586/U |
| | Indicator, panoramic, IP-1355/GRR-8(V) |
| Tuner Assembly, WJ-9120, Tuning Head | Tuner, RF, TN-586/GRR-8(V) |
| Tuner Assembly, WJ-9121 | Tuner, RF, TN-584/GRR-8(V) |
| Tuner Assembly, WJ-9124 | Tuner, RF, TN-585/GRR-8(V) |

0.8 REPORTING EQUIPMENT IMPROVEMENT RECOMMENDATIONS (EIR)

If your receiver needs improvement, let us know. Send us an EIR. You, the user, are the only one who can tell us what you don't like about your equipment. Let us know why you don't like the design or performance. Put it on an SF 368 (Product Quality Deficiency Report). Mail it to: Commander, US Army Communications-Electronics Command and Fort Monmouth, ATTN: AMSEL-PA-MA-D, Fort Monmouth, NJ 07703-5000. We'll send you a reply.

0.9 WARRANTY INFORMATION

The receiver is warranted by Watkins-Johnson Company for a period of one year following delivery. It starts on the date found in block 23, DA Form 2408-9, is the logbook. This warranty may contain repair restrictions. Report all defects in material or workmanship to your supervisor.

FIGURE 1-1

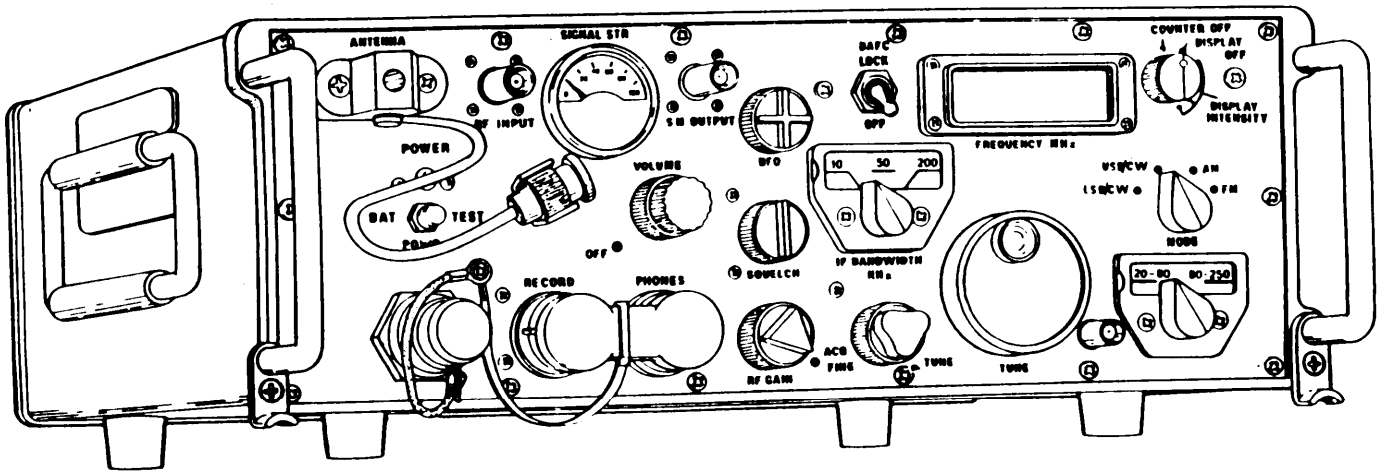


Figure 1-1. Type WJ-8640-1 VHF Portable Receiver

SECTION I

GENERAL DESCRIPTION

101 ELECTRICAL CHARACTERISTICS

1 .1.1 The WJ-8640-1 Manpack Receivers a rugged portable unit designed to operate under extreme environmental conditions, and receive AM, FM and CW emissions. Sideband filters are employed when receiving SSB/CW signals in the 0.5-30 MHz and 20-80 MHz range.

1.1.2 The use of either the WJ-9120, WJ-9121 or the WJ-9124 Tuning Head enables the Receiver to cover the frequency range of 0.5-30 MHz, 20-250 MHz or 250-500 MHz respectively. Located on the Receiver's front panel is the BAND (MHz) selector switch. These tuning assemblies are interchangeable drop-in units requiring simple hand tools for installation and removal. The receiver employs three standard IF bandwidth filters of 10, 50 and 200 kHz. These bandwidths are front panel selectable.

1 .1.3 In addition to the IF and RF Band Selectors, Front Panel Controls associated with the receiver set the RF Gain, Squelch, Tuning Receiver Mode and variable BFO Frequency, Counter ON/OFF and display and DAFC.

1 .1.4 The Receiver employs a built-in frequency counter with a six digit display and a tuned frequency readout within a resolution of 1 kHz. The counter includes Digital Automatic Frequency Control (DAFC) circuitry, whose operation locks the tuned frequency to within 1 kHz, over the entire tuning range. The Counter display switch, located on the front panel, does not permit DAFC operation when the COUNTER OFF position is used. With the DISPLAY OFF mode chosen the DAFC will continue to operate. The controls associated with the counter are the COUNTER OFF-DISPLAY OFF-DISPLAY INTENSITY switch and the DAFC LOCK-OFF switch.

1 .1.5 Audio outputs from the Receiver are available at two output locations which are both front panel located. The RECORD output is a multipin connector that can be connected to a recorder. The other audio output is a multipin connector which can be utilized to drive a headset. Also located on the Receiver's front panel is an external power connector.

1 .1.6 The WJ-8640-1 may be operated from an attachable battery pack which can hold either a magnesium BA-4386 or ten high capacity D-cell batteries. In addition to the battery pack the WJ-8640-1 may be operated from an external source of +12 or +24 Vdc. A charger is available as an option when operated from a 110/220 Vac source.

1.2 MECHANICAL CHARACTERISTICS

102.1 The WJ-8640-1 Receiver is packaged in a cabinet that is 4.2 inches high, 11.38 inches wide and 11.75 inches deep. A snap-on battery will increase the unit's depth to approximately 14.25 inches.

1.2.2 All operator controls are located on the front panel, with each control having a different color and shape for better identification. The power input on the front or rear panel and the RF input on the front panel are the only inputs necessary for this unit's operation. The Audio Output jacks, located on the front panel, are provided for their use with either an external tape recorder, a set of headphones or the Front Cover Speaker Panel.

1.3 EQUIPMENT SUPPLIED

This equipment consists of the Type WJ-8640-1 Portable Receiver, a battery pack and all necessary mating connector's and extender cards for the proper operation and maintenance of the receiver.

1.4 EQUIPMENT REQUIRED BUT NOT SUPPLIED

The following is a list of necessary options required for the proper operation of the Portable Receiver. A type 994-9913 headset, if the speaker contained in the cover is not used, 10 D-size flashlight cells or a BA-4386/PRC - 25 battery for use as an internal power supply, an external antenna of 50 ohms and a comparable tuning head (listed on specification sheet). A tape recorder may also be connected for recording of the desired signals in addition to a signal monitor such as the WJ-9180-1.

SECTION II

INSTALLATION AND OPERATION

2.1 UNPACKING AND INSPECTION

2.101 Examine the shipping carton for damage before the equipment is unpacked. If the carton appears to be damaged, try to have the carriers agent present when the equipment is unpacked. If this is not possible, retain all packing material and shipping containers for the carrier's inspection if damage to the equipment is evident after it has been unpacked.

2.1.2 See that the equipment is complete as listed on the packing slip. Contact Watkins-Johnson Company, CEI Division, Gaithersburg, Maryland, or your Watkins-Johnson representative for any discrepancies or shortages.

2.1.3 This unit was thoroughly inspected and factory adjusted for optimum performance prior to shipment. It is, therefore, ready for use upon receipt. After uncrating and checking contents against the packing slip, inspect the unit for dents or scratches. If external damage is evident, make an internal inspection. Check the internal cables for loose connections.

2.2 INSTALLATION AND REMOVAL PROCEDURES

The information listed below will provide the necessary instructions needed for proper battery and tuner installation and removal, for portable receiver operation.

2.2.1 BATTERY INSTALLATION - (TYPE BA-4386/PRC-25)

- (a) Place the receiver on a clean flat surface so that it rests on the protective handles that extend from the front panel.
- (b) Turn the latch handles on the side of the rear cover fully counterclockwise and pull the latches away from the sides of the receiver.
- (c) Remove the rear cover and lift the old battery off the rear of the receiver case.
- (d) Plug the new battery into the receptacle on the rear of the case.
- (e) Put the dust cover over the battery. Fold the latches against the sides of the case.

- (f) Turn the handles on the latches fully clockwise, making sure the latches properly engage the hooks on the receiver case.
- (g) Return the receiver to its upright positions. Energize the receiver by rotating the VOLUME Knob from its OFF position and press the BATTERY/TEST pushbutton on the front panel. The red light above the pushbutton should remain lit, indicating that the battery is good. If the light goes off it is an indication that the battery is below its normal level and should be changed immediately.

NOTE

Do not continue to hold the press-to-test button as this will cause an unnecessary battery drain.

2.2.2 INSTALLATION OF D-CELLS IN THE D-CELL INSERT

- (a) Remove the D-Cell Insert from the rear of the receiver as in steps (a) through (c) above (paragraph 2.2. 1).
- (b) Unclip the black cardboard tubes holding the D-cells from the insert.
- (c) Remove the cells from the cardboard tubes.
- (d) Slide the new D-cells into the cardboard tubes, making sure that the cells in each tube point in the same direction.
- (e) Clip the cardboard tubes and D-cells back into their holders, making sure that the cells face in the direction indicated on each of the holders.
- (f) Replace the D-cell insert by reversing steps (a) through (c) of paragraph 2.2.1.

2.2.3 REMOVAL AND INSTALLATION OF TUNER ASSEMBLY

- (a) Place the receiver on a clean flat surface so that it rests on its bottom side.

- (b) Turn the latches that hold the front panel cover to the receiver counterclockwise. Pull the latches away from the sides of the receiver until the cover is able to be removed.
- (c) Remove the four (captive type) slot screws that hold the front panel of the receiver to the outer protective cover. These screws are located on the rear corner edges of the receiver's front panel.
- (d) Holding the front panel by its protective handles, pull it away from the battery pack. After removing the receiver's main chassis from its protective case (and disconnecting its power connection) the receiver may be layed on a clean flat surface: protective handles nearest you and the bottom side up
- (e) Using an allen wrench, loosen the allen screws on both ends of the flexible coupling (tuning shaft-spring extender) until it can be disconnected from the tuning shaft.
- (f) Disconnect the six coaxial connectors labeled J1 through J6 from the plate board that extends off the rear side of the tuner's main frame.
- (g) Remove the multipin plug A2P1 from its receptacle J7, located directly behind the coaxial connectors, by pulling it away from its receptacle.
- (h) Using a slot-type screwdriver, release the three spring-loaded captive screws that secure the base (right-side) of the tuner to the receiver's main chassis.
- (i) Remove the two upper-most machine screws that are located on the left vertical side of the tuner's frame using a phillips-type screwdriver.
- (j) Remove the tuner assembly from the receiver's main chassis by lifting it directly upward.
- (k) To replace the tuner, reverse steps (a) through (j) above and note caution below.

CAUTION

Extreme caution should be used in re-seating the receiver's main chassis into its protective case. A problem may be caused by the failure of A9; P1-J6, to properly mate. If this problem is encountered, remove the rear mounted battery cover and reconnect the plug manually.

2.3

OPERATION

- (1) Power Source - Connect the receiver to a suitable power source. The Battery Pack Assembly (A9) or an external dc source may be used. When an external source is used, jack J5, located on the front of the receiver, is the input.
- (2) Antenna Connection - Connect a 50 ohm antenna to the antenna adapter block assembly. Then connect the BNC connector to the front panel jack labeled RF INPUT.
- (3) Record Output - Use the RECORD receptacle to connect a tape recorder to the receiver.
- (4) Audio Output - Connect to the AUDIO receptacle a suitable pair of headphones, such as a Type 994-9913 (WJ-8640/HS) or the loudspeaker which is located in the front panel dust cover.
- (5) SM Output - Connect to the BNC connector marked SM OUT a signal monitor such as the WJ-9180-1 or other suitable devices that require a 10 MHz IF signal.
- (6) Battery Test - Turn on unit. Depress the BAT/TEST pushbutton. The red test light mounted directly above it will remain lit if the receiver's present battery supply is sufficient for normal operation. If the light fails to luminate while the receiver continues to function properly, the present battery is near the end of its useful life and a fully charged replacement should be installed.

- (7) Volume Control - Rotate the control knob labeled VOLUME in the clockwise direction to first apply power to the unit. This control varies the amplitude of the audio signal.
- (8) Squelch Control - The control knob labeled SQUELCH may be turned fully clockwise to disable the receiver's squelch circuits.
- (9) Display Intensity - Turn the control knob for DISPLAY INTENSITY until numbers are visible on the FREQUENCY MHz display panel. Once the desired frequency has been selected the DISPLAY/OFF position may be selected. This will save valuable battery power plus maintain DAFC control.
- (10) Mode Control - The mode of the receiver is controlled by this knob. AM, FM, USB/CW or LSB/CW should be selected for the desired signal.
- (11) IF Bandwidth Switch - The IF BANDWIDTH kHz switch sets the bandwidth of the IF signal to 10 kHz , 50 kHz or 200 kHz. When searching for a signal it is advisable to set the IF bandwidth to the widest available.
- (12) Band Select Switch - This switch has two positions . When the WJ-9120 is used the low band covers the 12-30 MHz range and the high band covers the 0.5-12 MHz range. when the WJ-9121 is used the low band covers the 20-80 MHz range and the high band covers the 80-250 MHz range. When the WJ-9124 Tuner is used, the high band of 80-250 MHz should be selected.
- (13) Tune Control Knob - Adjust the control knob until the number of the desired frequency is displayed on the FREQUENCY MHz display.
- (14) Fine Tune Control Knob - Adjust this knob until the exact frequency that is desired is displayed.
- (15) DAFC Lock Switch - When the desired frequency has been tuned to, turn the DAFC switch to the LOCK position, if DAFC is desired.

- (16) AGC/RF Gain Control - To engage the AGC circuitry, rotate the RF GAIN control knob fully clockwise until it clicks. The AGC may be employed during all MODES of operation.
- (17) BFO Control - Adjust the BFO control knob to obtain a clear signal when receiving in the CW mode.
- (18) Squelch Control - Rotate the SQUELCH control knob counterclockwise until background noise is eliminated with no signal being received.
- (19) Signal Strength - When receiving RF signals in the receiver's range, this meter indicates the video signal level until AGC action begins. In the manual gain mode the meter reads only the average video signal level.

2.4 PREPARATION FOR RESHIPMENT

If the unit must be prepared for reshipment, the packaging methods should follow the pattern established in the original shipment. If retained, the original materials can be used to a large extent or will at a minimum provide guidance for the repackaging effort.

SECTION III

CIRCUIT DESCRIPTION

3.1 GENERAL

3.1.1 Operation of the circuitry found in the WJ-8640-1 Portable Receiver is described in the following paragraphs. Figure 3-1 is an overall functional block diagram of the WJ-8640-1, and the subsequent paragraphs describe its operation. Note that the unit numbering method is used for electrical components, which means that parts on subassemblies and modules carry a prefix before the usual class letter and number of the item (such as A1R1 and A4Q1). These subassembly prefixes are omitted on illustrations and in the text except in those cases where confusion might result from their omission.

3.2 FUNCTIONAL DESCRIPTION

3.2.1 The following paragraphs describe the major modules in the WJ-8640-1 Portable Receiver. The modules are described to give the operator a basic understanding of the functions performed by the receiver. The descriptions are keyed to the main chassis schematic diagram.

3.2.2 TYPE 791783 ANTENNA SWITCH ASSEMBLY (A1)

3.2.2.1 The Antenna Switch Assembly (A1) applies the RF carrier to the selected tuning head, located inside the Tuner Assembly (A2).

3.2.3 The different type tuner assemblies (A2) are referred to in note 5 of the main chassis schematic Figure 6-21.

3.2.3.1 The schematic diagrams concerning these assemblies are found in their respective instruction manuals. The tuners amplify an incoming signal and mix it with a local oscillator output to provide a 21.4 MHz IF signal or a 10 .MHz IF signal. These mixer outputs are fed to the IF Demodulator module (A4).

3.2.4 TYPE 791806 COUNTER ASSEMBLY (A3)

3.2.4.1 The Counter Assembly (A3) amplifies a signal from one of the two local oscillators in the Tuner Assembly (A2) and converts it to the frequency being received. This tuned frequency is displayed on six Light Emitting Diodes which are located on the unit's front panel. The Counter supplies a Digital Automatic Frequency Control (DAFC) voltage to the oscillators that can be used to lock the receiver to the frequency on the display. The display can be varied in intensity or turned off to conserve power without affecting the DAFC circuits in the frequency counter. Full CCW of this control removes total power from the counter. The DAFC is disabled when the counter is OFF.

3.2.5 TYPE 791800-1 IF DEMODULATOR ASSEMBLY (A4)

3.2.5.1 The IF Demodulator Assembly amplifies and demodulates the IF signal provided by the tuner. The bandwidth of the IF amplifier can be set at 10 kHz, 50 kHz or 200 kHz with three selectable bandpass filters. The AM Detector subassembly amplifies and demodulates the IF amplifier output when the receiver is in the AM mode.

3.2.5.2 When the receiver is in the LSB/CW or USB/CW mode, the IF signal is amplified by the AM Detector and applied to the Product Detector. The Product Detector mixes the signal with the output of the crystal-controlled BFO (Beat Frequency Oscillator) operating at 10 MHz. The BFO control can be tuned to provide an intelligible SSB signal or to provide a clear tone from a CW signal.

3.2.6 TYPE 791817 AGC SQUELCH (A5)

3.2.6.1 The AGC Squelch Assembly (A5) provides an AGC voltage to the IF Demodulator and Tuner modules and Squelch voltages to the Audio Record Amplifier Module (A8). The Squelch circuit activates a relay to operate a tape recorder when a signal is being received.

3.2.7 TYPE 791794 DC/DC CONVERTER (A6)

3.2.7.1 The DC to DC Converter Assembly (A6) , takes 11.0 to 16 volts from a battery pack or external power source and supplies +15 V, +6 V and +9.5 V DC to the other modules in the receiver. This module also tests the battery. When the BAT/TEST (Battery Test) button is pressed on the front panel of the receiver, a 20-ohm test load is connected to the battery. If the battery voltage falls below 11 volts, the lamp above the pushbutton will go out, indicating that the battery is near the end of its useful life. When the power light is unlit and the receiver is on, the battery voltage is below the 11 V threshold level.

3.2.8 TYPE 791784 FM DISCRIMINATOR (A7)

3.2.8.1 When the receiver is in the FM mode, the IF signal is amplified by the AM Detector subassembly and applied to the FM Discriminator module (A7). The output of the discriminator is scaled to supply equal outputs of approximately 1.0 Vrms at the RECORD output for signals with 30% deviation at any of the three available bandwidths.

3.2.9 TYPE 7464 AUDIO/RECORD AMPLIFIER (A8)

3.2.9.1 The Audio-Record Amplifier Module (A8) amplifies the audio signals applied by the AM Detector, FM Discriminator and Product Detector circuits. The amplifier provides a fixed output to drive an external tape recorder and a variable output to drive a pair of headphones or the loudspeaker that is housed

in the front panel dust cover. The amplifier's fixed output provides a wideband (200 kHz) video output capable of supplying a 1 Vrms signal across 100 ohms from a received signal having 30% deviation in a given bandwidth in the FM mode or 50% modulation in the AM mode.

3.2.10 TYPE 791795-1 BATTERY PACK (A9)

3.2.10.1 The receiver operates from a detachable battery pack that is fixed to its rear chassis. The battery pack contains either a magnesium BA-4386/PRC-25 or ten high capacity D-cell nickle-cadium (Nicad) or alkaline batteries. A full charge from the battery pack supplies a maximum of +15 volts. A battery pack with a built-in charger is offered as optional equipment.

NOTE

CARBON ZINC BATTERIES
SHOULD NEVER BE USED.

3.2.11 TYPE 791809-1 FRONT PANEL COVER WITH SPEAKER (A10) - One of the available outputs from the Audio/Record Amplifier (A8) provides an output which drives a speaker that is located within the receiver's front panel cover.

3.3 DETAILED CIRCUIT DESCRIPTION

3.3.1 The following paragraphs describe the functions and conditions of operation of the receiver's modules. Reference to the receiver's simplified block diagram, individual parts list figures and the specified schematic diagram in Section VI will be an invaluable aid in its understanding.

3.3.2 TYPE 791783 ANTENNA SWITCH (A1)

The schematic diagram associated with this module is Figure 6-1; its reference designation is A1 .

3.3.2.1 The RF signals enter the Antenna Switch Assembly via jack J3 (Antenna Input). This signal is applied to relay pin #2 which is connected to the relay's armature. When the High Band is selected, relay pins #2 and #4 are connected and the RF signals are routed to output jack J1 . When the High Band is front panel selected a +9.5 volts is applied across pins #8 and #1 to ground. This voltage, which passes through the relay's coil, attracts the armature until it connects pin #3 to pin #2. The RF signal is now connected to output jack J2 (Low Band Input).

3.3.3 TYPE WJ-9120, WJ-9121 AND WJ-9124 TUNER ASSEMBLIES (A2)

The circuit descriptions for these tuners may be found in the WJ-9120, WJ-9121 and WJ-9124 Tuner Assembly manuals.

3.3.4 TYPE 791806 COUNTER ASSEMBLY (A3)

The schematic diagram for this module is Figure 6-2; its reference designation is A3.

3.3.4.1 Type 34912 Wideband Amplifier and First Counter (A3A2) - The schematic diagram for this subassembly is Figure 6-5; its reference designation is A3A2.

3.3.4.1.1 This subassembly takes as an input one of two LO outputs. This signal is gated into a divide by 10; this being the first decade in the counting chain. The output data from this module is in BCD form (1 four bit word). In addition to the BCD output word the carry clock is continued to the next decade of the counting chain. The reset line is used to initiate a count period and reset the first decade counter. The end of count line ends the count period after 1, 2 or 4 ms. The +6 Vdc power supply line (E1 2) to the board is turned on only while the board is counting, the V BAT supply is on continuously. The +6, +9.5 and -15 Vdc supplies entering the board use the caps on the board for filtering.

3.3.4.1.2 Upon entering the board the signal first passes through a variable attenuator stage (Q1 and Q2). Transistor Q3 is used to amplify the AGC signal fed back through detector CR3. Amplifiers U1 and U2 provide gain to raise the signal level above the threshold needed by the ECL counter. Transistor Q4, resistors R15 through R16 and diode CR4 are used to switch the 9.5 Vdc power supply, to amplifiers U1 and U2, on and off.

3.3.4.1.3 The amplified signal is fed into a MC1690 divide by two chip which is capable of counting to 300 MHz. Resistors R20 and R23, transistor Q6 and diodes CR5 and CR6 form the biasing network that determines the bias point for the chip. U3 and resistors R24 through R27 form two voltage dividers that convert the reset and end of count TTL levels to ECL levels.

3.3.4.1.4 After division by two the signal is fed to a divide by five chip, U4. The outputs from U4 (Q1, Q2, Q3) form a BCD word which is brought out from the board. Resistors R33 through R38 reduce the TTL signals down to ECL levels. Components R49, R50, L3 through L10, C13 through C20 and FB2 through FB5 are all used in decoupling of the power lines to the high speed counters. Resistors R39, R40 and R41 couple the Q3 and Q3 outputs from U4 to the differential amplifier consisting of Q7, Q8 and R42 through R46. Transistor Q9 forms an emitter follower amplifier which presents a low output impedance that is capable of driving a TTL input.

3.3.4.2 Type 791808 Counter (A3A1) - The schematic diagram, for this subassembly is Figure 6-3; its reference designation is A3A1.

3.3.4.2.1 The Counter board uses as its inputs the BCD data and carry outputs from the Wideband Amplifier and First Counter subassembly. The other input connections are from the band select switch and the DAFC switch which are both located on the units front panel. The voltage input is +6 Vdc for CMOS logic and displays. The DISPLAY INTENSITY Switch determines the brightness of the LED displays and Counter ON/OFF. Outputs from the board consist of the end of count and reset which are TTL levels and are sent to the wideband Ampl. board. A +6 Vdc switched voltage is also sent to the Wideband Ampl. and a DAFC control voltage is sent to the tuner. Visual output of the received frequency is done through multiplexed 7-segment displays.

3.3.4.2.2 The board contains 5 decade counters for counting the frequency, a timing chain for count gate, a 1 MHz oscillator for the timing chain reference and latches for six decades of BCD DATA so that it can be multiplexed. Preset data is loaded according to the position of the Band Select switch.

3.3.4.2.3 Timing chain - the timing chain originates at the 1 MHz oscillator which is buffered by UIE and UIF. The signal is then divided by 10 using U2A. The 100 kHz signal is used to clock the end of count and reset flip-flops to make their edges sharply defined. Next in the timing chain is another divide by 10 (U2B) IC. The 10 kHz signal from U2B is used to drive a variable modulus counter. In normal operation (no count cycle) the counter is a divide by 2. In this mode the displays are multiplexed fast to prevent any noticeable jitter when viewing. When a count cycle is needed the counter may be changed to divide by 4 or divide by 8. When the 250-500 MHz band is selected, the divide by 4 modulus is used. When the 500-1000 MHz band is selected, the divide by 8 modulus is used. The higher modulus is used only to stretch the count cycle to 2 ms or 4 ms. This "expanded count cycle" is need in the higher band due to prescaling of the LO signal in the tuning head. The outputs from U6 are selected by gateing to produce proper timing for the end of count, reset, preset and the display "on time" pulses. The next chip is a divide by 8 with an internal decoder, U7. This chip is used to strobe the six-segment LED displays and the correct corresponding decimal point. Two "D" flip-flops at the carry output of U7, arranged as a divide by four, determine when a count cycle is active.

3.3.4.2.4 Counting chain - the counting chain consists of U19 through U23 which are all BCD decade counters. They are all presetable. Transistors Q7 and Q8 correct the signals polarity to make sure the counters are triggering on the proper edges. Transistor Q7 also acts as a buffer from the input to the board

3.3.4.2.5 Preset section - the preset number for each band is first determined by the band select switch. Each position of the switch is connected to the proper position in a gate decoding network consisting of U16A, U16B, U17A, B, C, E, F and diodes CR1 and CR2.

3.3.4.2.6 Storage section - U25B, U26B, U27A, U27B, U28A, U28B all store the frequency counted information while U25A and U26A store the DAFC information.

3.3.4.2.7 DAFC section - Comparators U30 and U31 plus flip-flop U32A and U33C determine if the frequency counter is higher, lower or equal to the stored DAFC information. The up, down or equal information is fed through U34A and U34B into U35 which switches the rate of change of the DAFC according to the band selected. U33D is used as an integrating amplifier with C7 and C8. The positive and negative going pulses from U35 are filtered by the integrator. The output voltage is buffered through U36.

3.3.4.2.8 Data conversion - U24 compares levels of the data coming from the wideband amplifier board to a threshold set by R23 and R24. For values above or below the threshold a one or zero will be stored in U25B. This data is also stored in U30 when DAFC is required.

3.3.5 TYPE 791800-1 DEMODULATOR (A4)

The IF Demodulator module contains nine subassemblies and their associated coupling components. The reference designations for these subassemblies follow a pattern similar to that used for the main chassis modules. Therefore, the first subassembly, A1, of the IF Demodulator, A4, will be designated as A4A1. In the following description the subassemblies will be discussed in the order of their appearance in the signal path. The schematic diagrams discussed in this section (3.3.5) are Figure 6-6 through 6-14.

3.3.5.1 Type 794485-1 21.4/10 MHz converter (A4A1)

3.3.5.1.1 Due to design considerations, the IF output from the tuner assembly may be 10 or 21.4 MHz depending on the tuner's frequency range. In order to demodulate the IF signal, it is necessary to convert the 21.4 MHz IF from the tuners down to 10 MHz. This subassembly performs the function using a crystal controlled 31.4 MHz oscillator which consists of Q2, Y1, C12, and L4. The 31.4 MHz signal then enters the double-balanced mixer, U1, at pin 1. The output of U1 is the difference frequency of 10 MHz. This signal is coupled through a 50 ohm pad consisting of R12, R13 and R15 to pin 4. This output is coupled to the SM OUT and the IF filters.

3.3.5.2 Part 24996 Bandwidth Control (A4A2), Type 791802 Gain BW Compensation Amplifier (A4A3) and Type 791803-1 IF Filters and Diode Switches (A4A4)

The activation of the bandwidth control circuits contained in these subassemblies are controlled by the front panel IF BANDWIDTH switch, S4. Since all three circuits are similar in their control and activation on the incoming signal

the 10 kHz bandwidth control circuit of A4A2, A4A3 and A4A4 will be described here. The schematic diagrams for A4A2 through A4A4 are Figures 6-8 through 6-10 respectively. In addition to the specific subassemblies described, the IF Demodulator and main chassis schematics should also be referred to for understanding in the overall circuit operation.

3.3.5.2.1 When the front panel located IF BANDWIDTH switch is set for a bandwidth other than 10 kHz (the absence of +15 Vdc at A4A2E3) a minus voltage is present at the output pin E12. This minus voltage that is present at A4A2E12 is connected directly to input pin 7 of subassembly A4A4. The negative voltage at A4A4 pin 7 forward biases CR2 thereby shorting any incoming signal to ground

3.3.5.2.2 When the 10 kHz bandwidth control is selected on the front panel a +15 Vdc is present at input A4A2E3. Due to the large resistance of R10 in comparison to the smaller resistance of R6, a greater amount of voltage will be dropped across R10. With a smaller amount of positive voltage dropped across R6, a positive voltage is present at the output of A4A2E12. Again this positive voltage is directly connected to A4A4 pin 7, where it forward biases CR1 thereby providing a path for the input signal to the output, A4A4 pin 1. Note that in Figure 6-10, A4A4, bandpass filters of 10 and 50 kHz are employed. The wide band filter of 200 kHz is located on the IF Demodulator main chassis, A4 (Figure 6-6).

3.3.5.2.3 When a particular bandwidth is chosen, a positive voltage is present at the appropriate A4A2 output (E12, E13 or E14). This positive voltage is also applied across the gate resistors of the Field Effect Transistors (FET's) Q1 through Q3. The respective FET is turned "ON" thereby allowing the AGC voltage (-10 Vdc to 0 Vdc) to be passed to A4A3 through E6, E7 or E8. These outputs are directly coupled to input pins 1, 2 and 3 of A4A3. The AGC voltage dc biases its common emitter transistor A4A3Q1 through A4A3Q3. With the input signal common to all transistors, only the circuit that is properly biased will pass and amplify the input signal. Potentiometers R13, R14 and R15 are in parallel with the emitter resistors. Increasing or decreasing the amount of their resistance will proportionately affect the rate of conduction (degree of amplification) through the transistors. To obtain the proper bandwidth gain compensation in the narrower bandwidth circuits, reduce the potentiometer resistance thereby enabling a greater current. The collectors are inductively tuned by L1 through L3, and capacitors C7-C8, C9-C10 and C11-C12 form voltage dividers for the output signals. The output signal is directly coupled to the appropriate pin and then sent to its corresponding input pin of A4A4.

3.3.5.3 Type 791804-110 MHz Amplifiers (A4A5 and A4A8)

3.3.5.3.1 The IF Demodulator module contains two 10 MHz Amplifier subassemblies. Each subassembly provides an approximate 23-25 dB maximum signal gain. The input signal enters at pin 6. Resistors R1 and R2 provide a voltage

divider for the biasing of amplifier Q1. The collector is inductively tuned by inductor L1 to pass the 10 MHz frequency spectrum. The output of subassembly A4A5 is pin 10 which is connected to the input of the AM Detector/Buffer (A6) at pin 9.

3.3.5.4 Type 791790 AM Detector/Buffer (A4A6)

3.3.5.4.1 The modulated audio signal enters the AM Detector/Buffer (A6) via pin 9. The 10 MHz signal is coupled by C2 to the base of Q1. R1 and R2 setup a voltage divider that determines the dc biasing. The signal is amplified and transformer coupled to the secondary of T1. It is tuned to pass the 10 MHz frequency spectrum by the tuning of variable capacitor C4. Diode CR1, C5, C6, and R6 help form an AM demodulation network. The varying current at the base of cascaded amplifier Q2 is amplified and direct coupled from its emitter to the base of Q3. The amplitude modulated signal is then direct coupled to output pin 2.

3.3.5.4.2 Prior to being coupled by C2, the 10 MHz signal is tapped off and is coupled by C16 to the base of Q5. Resistor R20-R24, C15-C18 and T3 perform the same functions as the AM circuitry described in paragraph 3.3.5.4.1. The secondary of transformer T3, which is tuned for 10 MHz, is tapped at pin 5. The signal is coupled by C9 to the base of Q4. Resistors R9 and R10 serve as a voltage divider for Q4. The signal is amplified and transformer coupled from its collector to pin 4 (IF output). From the emitter of Q4 the signal is coupled, through C13 and R18, to the FM and SSB outputs at pin #6. These subassembly output pins are direct coupled to the module output jacks of the IF Demodulator.

3.3.5.5 Type 791785 Product Detector (A4A7)

3.3.5.5.1 This subassembly is operational when the receiver is set to either the LSB/CW or the USB/CW mode. Crystal-controlled Colpitts oscillator, Q1, supplies a 10 MHz LO signal to amplifier Q2. Transformer T1 is connected across the collector load, R6, and couples the LO signal to the carrier input of the product detector, U1. The IF signal from the LSB/USB Board is coupled to the signal input of U1, which is dc biased by voltage divider networks at the end of pin 4. The audio output of the product detector, U1, is applied to operational amplifier U2 which provides an approximate gain of 10. The output of U2, pin 6, is the SSB/CW output of the IF Demodulator module assembly.

3.3.5.6 Type 791805 LSB/USB Filters (A4A9) - The schematic diagram for this subassembly consists of FL1 and diodes CR1 through CR4. When the LSB/CW mode is selected on the receiver's front panel, a positive 9.5 Vdc is applied to pin 9. This positive voltage forward biases CR5, passing the voltage to output pin 5 and onto the PRODUCT DETECTOR subassembly (A4A7). The +9.5 Vdc also takes two additional paths. one passes through R8, CR3 and R10 with the other passing through R1, CR1 and R2. When the input signal enters the side-band filter (A4A9) at pin 10, capacitor C1 couples it through CR1 (forward biasing

it), through coupling capacitor C2 and into FL1's lower sideband input port, IN 1. At the filters output, OUT 1, the signal is coupled by C4, through CR3 which is forward biased, through C6 to the output, pin 1. When the USB/CW mode is front panel selected, CR6, CR4 and CR2 are forward biased and the input signal follows similar circuit logic using the IN 2, OUT 2, ports of FL1 thereby producing the upper sideband portion of the received signal.

3.3.6 TYPE 791817 AGC/SQUELCH (A5)

3.3.6.1 The Automatic Gain Control (AGC) circuitry consists basically of Q2, Q3 and U1. The AM signal's dc component enters the module via pin #14 (AM). After passing through a low-pass filter consisting of R3 and C2, the signal is applied to the base of Q2 where it is amplified. The signal is tapped off the collector and applied to module pin #11 where, dependent upon the setting of the front panel AGC control knob, it is either applied to pin #11 or not used. S3, a double-pole, double-throw switch is a two-position switch that controls whether AGC or manually set RF Gain is employed. When AGC is used, the signal present at pin #11 is applied to pin #21. When the AGC is "OFF" the amount of AGC is determined by the potentiometer setting of R5. No matter what mode is used a positive dc voltage will be applied to the base of Q3 which amplifies it. The signal is taken from the emitter and applied to the IF AGC pin #22 output. This dc signal is then sent to the IF Demodulator (A4). A portion of this emitter signal is affected by the constant current source of Q4 and its associated circuitry and applied to the non-inverting input of OP AMP, U1. With the IC's feedback components, consisting of C4, CR3, R17 and R13, a small signal gain of 11 is achieved at its output at pin #6. VR1 limits this output to prevent it from exceeding 8.2 Vdc. The signal is sent from pin #16 (RF AGC) to the tuner's RF gain control components.

3.3.6.2 The Audio Squelch and COR Relay circuits are controlled by the dc signal present at pin 14, U2, U3, Q5 and their associated components. At the base of Q2 a portion of the signal is sent to the non-inverting input of OP AMP, U2. Feedback components consist of CR4-CR7, R23-R26 and C7. The amplified output voltage level is added to the squelch voltage at the R27-R30 junction. When the squelch voltage is slightly greater than the output of U2 the output at A5 pin #3 presents a negative voltage thereby producing squelch. Once the output of U2 slightly exceeds the squelch voltage, the OP AMP, U3, operating in a positive feedback configuration amplifies the input signal of pin #3. This positive voltage at its output (pin #6) is applied to Q5 which amplifies it and applies it to pin #1 of the module (COR Relay), thereby activating the COR Relay. This signal that is present at U3 pin #6 is also passed through R34 to pin #3 (Audio Squelch).

3.3.7 TYPE 791794 DC-DC CONVERTER ASSEMBLY (A6)

3.3.7.1 The schematic diagram for this module and its related printed circuit card is Figure 6-16; its reference designation is A6.

3.3.7.2 The major function of this module is to transform the receiver's power supply voltage into regulated voltages of ± 15 volts, +9.5 volts, +6 volts and to provide the Battery Test lamp with an indication of the batteries voltage level.

3.3.7.3 U 1 and its associated components provide a regulated +9.5 Vdc supply voltage from the equipment battery source. The battery voltage enters the modules subassembly board at pin A1E4. The supply voltage is filtered by the R-C combination of A1R1 , A1C1 , A1C2 , A1C3 and A1C4. The voltage dropped across A1R8, and A1VR1 establishes a 6.8 Vdc level at A1C7. Transistors A1Q1 and Q1 (mounted on main module board) provide A1U1 with a feedback loop back to its non-inverting input (pin 3). The output of A1U1 will change accordingly to maintain a +6.8 Vdc reference voltage at its non-inverting input. Potentiometer R14 is set to maintain a +9.5 Vdc regulated supply voltage output.

3.3.7.4 A1U2 and its associated components provide a regulated +6 Vdc supply voltage from the battery source. The +6.8 Vdc reference source at A1VR1 is divided across R16 and R17 to give +3.4 volts at the inverting input of A1U2. Transistors A1Q2 and Q2 (main module board) form a feedback loop for operational amplifier, U2, from its output (pin 6) to its non-inverting input (pin 3). The output of U2 will change accordingly to maintain a +3.4 vdc reference voltage at its non-inverting input. Potentiometer R12 is adjusted to produce the desired +6 Vdc regulated voltage supply at A6A1 (pin 5).

3.3.7.5 Integrated circuit, U3, and its associated components, including T1 and T2, provide a +15 Vdc and -15 Vdc from the +9.5 Vdc regulated supply voltage. The +9.5 Vdc regulated voltage is applied to A1U3, an integrated timer circuit which operates as an astable multivibrator. The duty cycle of the timer's output is controlled by components A1R18, A1R19, A1R20 and A1C89. The multivibrator's output results approximately in a 20 kHz square wave with a peak voltage level of 9.5 volts. As this signal passes through the transformer A1T1 a +4.2 volt peak is induced in the secondary. The introduction of this signal causes the push-pull configuration transistors, A1Q3 and A1Q4, to alternately conduct. During one-half cycle, diode A1CR3 clamps the base circuit of transistor A1Q4 at approximately -0.6 volts. Due to this clamping, roughly +3.6 volts are applied to the base of transistor A1Q3, driving it into saturation. During saturation, approximately +0.5 volts is dropped across the collector-emitter junction of A1Q3. In the next half-cycle the process is repeated for the other components. The 9 volts (peak-to-peak) in the primary of A1T2 will induce approximately 30 volts peak in each half of the center-tapped secondary. The signal is then rectified by the full-wave bridge rectifier, A1J5 .

3.3.7.6 A1U4 and its associated components provide the battery test lamp source. Operational amplifier, A1U4 , is used to supply voltage to the front panel BAT TEST LED. The battery voltage is dropped across A1R25 and A1VR2, via pin 4, leaving a +6.8 volt reference at the inverting input of A1U4 (pin 2) when the

battery supply voltage is greater than +11 Vdc. Resistor A1R24 provides positive feedback to produce a hysteresis action that prevents the LED from flashing when the voltage level is close to the threshold level (+11 Vdc). When the battery level drops below +11 volts, the output of A1U4 drops to approximately +2 Vdc. The voltage drop across A1R23 and A1CR1 will then prevent the LED from lighting, in this low battery voltage condition.

3.3.8 TYPE 791784 FM DISCRIMINATOR ASSEMBLY (A7)

3.3.8.1 Two symmetrical limiter stages, A1Q1-A1Q2 and A1Q3-A1Q4, remove amplitude variations in the incoming FM signal so that when it is applied to the discriminator, it varies in frequency only. The incoming IF signal enters the assembly via jack J1, and is centered at 10 MHz. Resistors R1-R2 set A1Q1's base bias. Likewise, resistors R7-R8, R11-R12 and R19-R20 set the base-bias for A1Q2, A1Q3 and A1Q4 respectively. Capacitors C4 and C9 provide coupling of the ac signal between the first and second sections of each limiter stage.

3.3.8.2 In the absence of any incoming signal, Q1 and Q2 emitter currents develop nominal voltage across their emitter resistors. When a signal is applied to the base of A1Q1, the positive going half-cycle causes heavy conduction through A1Q1 which increases the voltage drop across A1R4. This varying emitter signal is coupled through A1C4 to A1Q2. Since this signal is applied to the emitter of Q2 it will tend to drive the transistor towards cut-off. If the input signal is sufficiently large in amplitude it will completely reverse bias the base-emitter junction. On the negative half-cycle of the input signal, the decrease in the amount of voltage dropped across A1R4 will cause A1Q2 to conduct into saturation. With the transistor operating between saturation and cut-off, it limits the amplitude of both the positive and negative cycles of the input signal. Capacitor A1C7 holds the base of A1Q2 at RF ground potential. Capacitor A1C8 couples the ac signal from the collector of A1Q2 to the base of the limiter's second stage, A1Q3. The second limiter's stage consists of A1Q3, A1Q4 and their associated components. Its operation is identical to that of the first limiter.

3.3.8.3 The amplitude limited IF signal is taken from the collector of A1Q4 and applied to the first of two tank circuits. A1C10, A1C12, A1L1 and the primary of the transformer A1T1 make-up the first. Capacitor A1C15 couples the RF reference voltage to the secondary of A1T1. The second filter consists of A1C16, A1C17 and A1C24. Each of these tank circuits are tuned to pass the 10 MHz IF signal. The tank circuits along with A1CR1 and A1CR2 combine to form a Foster-Seeley discriminator. The diodes A1CR1 and A1CR2 demodulate the FM signal. The discriminator's output will follow the required "S" shape whose amplitude depends upon the amount of deviation the input frequency varies from the center frequency. Its output frequency is dependent upon the assembly's input frequency which will be the 10 MHz IF signal. The audio signal from the discriminator's output is fed to cascaded emitter followers Q5 and Q6. Q5 acts as a high impedance

buffer stage. The signal from Q5 is directly fed to the base of Q6 which provides current amplification. The placing of CR3 on the collector of Q6 prevents the devices over-conduction. The discriminated output signal is taken from the emitter of Q6.

3.3.9 TYPE 7464 AUDIO AND RECORD AMPLIFIER (A8)

3.3.9.1 The schematic diagram for this module is Figure 6-18; its reference designation prefix is A8. Contained on the board are circuitry that provide three separate functions; bandwidth gain compensation, squelch and amplification and record level output amplification.

3.3.9.2 Integrated circuit U1 and its associated components provide various gains of the FM signal. The amount of gain is dependent upon the amount of bandwidth that is desired. To compensate for changes in FM mode audio levels, due to bandwidth selection, integrated circuit U1 is switched into the FM signal path between the discriminator's output (A7P1 pin C) and audio amp input (A8 pin 10). This occurs whenever the medium or narrow bandwidth is selected. In the medium bandwidth, FM mode of operation, +15 Vdc is applied to the gate of FET Q1 via main chassis switch S4Z. The FET is switched "ON" and the gain of U1 is determined by the parallel combination of R7, R8 and C2. When the narrow bandwidth mode is selected, -15 Vdc is applied to the gate of Q1. The "removing" of that path of the op-amps feedback path eliminates R7 from the circuit. The gain of A1U1 will therefore increase due to the higher parallel impedance of R8 and C2.

3.3.9.3 The squelch control voltage that is produced in the AGC Squelch module (A5) is applied to Audio and Record Amplifier module; A8 pin 11. This squelch control voltage is then applied to the gate of the FET, Q2. When activated, approximately -13 Vdc is applied to the gate of Q2, switching it "OFF" and preventing any signal from being amplified by the integrated circuit operational amplifier, U2. When the squelch control is inactive, the FET, Q2, receives a positive voltage, switching it "ON". The audio signals that are present at pin #10 are then able to pass through Q2 and be amplified by U2. This operational amplifier provides a fixed gain of approximately 10 and presents a low impedance output. The gain determining components are comprised of C5, R13 and R11. The input level of the audio signal presented to U2 is controlled by front panel mounted potentiometer, R10.

3.3.9.4 The input signal to the record amplifier is taken from the audio input line, and its level is controlled by potentiometer, R11, which is located on the main chassis deck. This signal is coupled to the base of Q3 through coupling capacitors C8 and C9. The base diode, CR1, along with R16 and R17, help establish bias and also temperature-stabilizes Q3's operation. The amplified signal is direct coupled from the collector of Q3 to the base of common-emitter driver, Q4. Diodes CR2 and CR3 set bias base-emitter voltages for Q5 and

Q6, a complementary-symmetry configuration. CR2 and CR3 also provide temperature compensation to prevent thermal runaway. The output signal is taken from pin #4 (RECORD OUTPUT).

3.3.10 TYPE 791795-1 D-CELL INSERT (A9)

3.3.10.1 The schematic diagram for this module is Figure 6- 19; its reference designation prefix is A9.

3.3.10.2 This unit houses the power source that is needed for proper operation (if portably operated) of the WJ-8640-1 Portable Receiver. With ten D-cell type batteries inserted in the module (polarity as shown on schematic diagram), a +15 Vdc (maximum) voltage potential is present across pins A and B of A9P1 and A9J1 .

3.3.11 TYPE 791809-1 FRONT PANEL PROTECTIVE COVER WITH SPEAKER (A10)

3.3.11.1 The schematic diagram for this module is Figure 6 -20; its reference designation prefix is A10.

3.3.11.2 This module contains the permanent magnet loudspeaker LS1 and an Audio Power Amplifier, A1 . The audio signal amplifier consists of Q1 and Q2. The circuit consists of a one-stage complementary-symmetry power amplifier. The audio signal enters the module via connector PI pin B. The signal enters the pc board A10A1 at pin E2. Capacitors C1 and C6 couple the audio signal to the base of Q1 and Q2. The signal is capacitively coupled using C3, C4 and C5 from the emitters of Q1 and Q2 to output load A10LS1 (main chassis board) via pins E4 and E5. Diodes CR1 and CR2 effectively set the correct operating base bias for Q2. On the collector lead of Q1 is CR3. The diode's primary responsibility is to prevent circuit damage caused by accidental voltage polarity reversal. Subassembly resistors A10R1 through A10R6 help set transistors Q1 and Q2 operating biases.

Courtesy of <http://BlackRadios.terryo.org>

SECTION IV MAINTENANCE

4.1 GENERAL

4.1.1 The WJ-8640-1 Portable Receiver has been designed to operate for extended periods of time with little or no routine maintenance required. An occasional cleaning and inspection are the only preventive maintenance operations recommended. The intervals for these operations should be based on the operating environment. Should trouble occur, repair time will be minimized if the maintenance technician is familiar with the circuit descriptions found in Section III. Reference should also be made to the block diagram Figure 3-1 and to the schematic diagrams found in Section VI. A complete parts list and illustrations showing part location can be found in Section V.

4.2 CLEANING AND LUBRICATION

4.2.1 The unit should be kept free of dust, moisture, grease and foreign matter. If available, use low velocity compressed air to blow accumulated dust from the exterior and interior of the unit. A clean, dry cloth, a soft bristled brush or a cloth saturated with cleaning compound may also be used. The WJ-8640-1 Portable Receiver does not need lubrication.

4.3 INSPECTION FOR DAMAGE OR WEAR

4.3.1 Many potential or existing troubles can be detected by a visual inspection of the unit. For this reason, a complete visual inspection should be made for indication of mechanical and electrical defects on a periodic basis, or whenever the unit is inoperative. Electronic components that show signs of deterioration should be checked and a thorough investigation of the associated circuitry should be made to verify proper operation. Damage to parts due to heat is often the result of other less apparent troubles in the circuit. It is essential that the cause of overheating be determined and corrected before replacing the damaged parts. Mechanical parts and front panel controls and switches should be inspected for excessive wear, looseness, misalignment, corrosion, and other signs of deterioration.

4.4 TEST EQUIPMENT REQUIRED

4.4.1 DEPOT TEST EQUIPMENT

The following instruments, or their equivalents, are required to properly troubleshoot, adjust or align the WJ-8640-1 Portable Receiver at the depot level.

- (1) power Supply, Hewlett Packard Model 6215A.
- (2) Oscilloscope, Tektronic Model 503.
- (3) Frequency Counter, Hewlett Packard Model 5245L with 5253B and 5254 C.
- (4) Signal Generator, Hewlett Packard Model 8640B.
- (5) Signal Monitor, Watkins-Johnson Model WJ-9180-1.

- (6) Sweep Generator, Hewlett Packard Model 675.
- (7) Detector, Telonic Model XD-3A.
- (8) Spectrum Analyzer (display, IF, Resections), Hewlett Packard Models 140T, 8552A, 8555A.
- (9) RF Voltmeter, Boonton Model 91 CA-S5 with 91-12F RF probe.
- (10) Impedance Comparator with Terminations, Telonic Rho-tector Model.
- (11) AC VTVM, Hewlett Packard Model 3400.
- (12) Digital Voltmeter, no specific model.

4.4.2 DIRECT SUPPORT TEST EQUIPMENT

The following instruments, or their equivalents, are required to properly troubleshoot the WJ-8640-1 Portable Receiver at the direct support level.

- (1) Multimeter, Digital, AN/PSM-45.
- (2) Voltmeter, RF, Boonton 92C.
- (3) Power Supply, PP-6547/U.
- (4) Oscilloscope, AN/USM-281 C.
- (5) Signal Generator, SG 1112(V)I/U with options 001, 002 and 003

4.5 TROUBLESHOOTING PROCEDURES

Troubleshooting efforts should first be directed towards identifying the symptom.

Once the symptom has been identified locate the symptom in the symptom index in Table 4-1. The troubleshooting procedure associated with the symptom will be found on the page number listed in the index. The first page of the troubleshooting procedure lists initial set up including required tools and equipment. The remainder of the procedure is in logic tree form and troubleshoots to the assembly, subassembly or piece part level.

Carefully follow the set Up procedures and follow the logic tree until the fault is isolated. A reference paragraph is provided within the tree for removal and replacement of the defective item.

4.6 PERFORMANCE TESTS

These procedures will provide an indication of satisfactory performance of the WJ-8640-1 Portable Receiver. The following paragraphs should be referred to whenever a critical component is replaced.

NOTE

Paragraphs 4.6.1 through 4.6.6 are the performance tests performed at the depot maintenance facility only. Paragraph 4.6.7 contains the performance tests to be performed at the direct support level.

4.6.1 IF REJECTION

(1) Connect the Receivers shown in Figure 4-1.

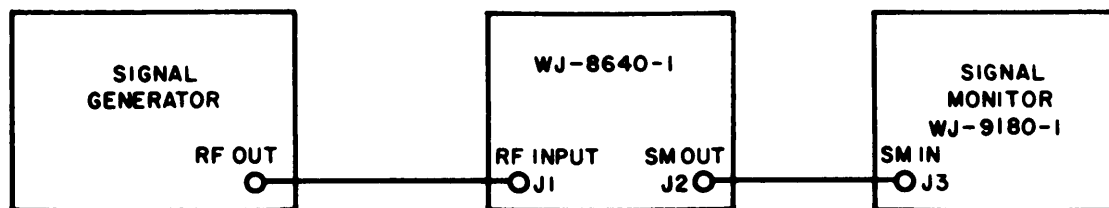


Figure 4-1. Test Setup, IF Rejection Circuit

- (2) Adjust the Receiver as follows; Band (MHz): Low, tune the receiver to 22 MHz, Mode: AM, RF GAIN: Maximum (fully clockwise (CW)).
- (3) Set the Signal Generator for a 22 MHz CW output level at -110 dBm.
- (4) Adjust the SM gain to obtain a convenient reference on the CRT.
- (5) Retune the signal generator frequency to 10 MHz.
- (6) Increase the signal generator output level until the reference level, obtained in step (4), is obtained.
- (7) Record the change in the signal generator output level. This level of IF rejection should be no less than 60 dB.
- (8) Readjust the Receiver's BAND control to High, and tune frequency to 80 MHz.
- (9) Set the signal generator to 80 MHz with an output level a -110 dBm.

- (10) Follow steps (4) through (7).

4.6.2 IMAGE REJECTION

- (1) Construct the circuit as shown in Figure 4-2.

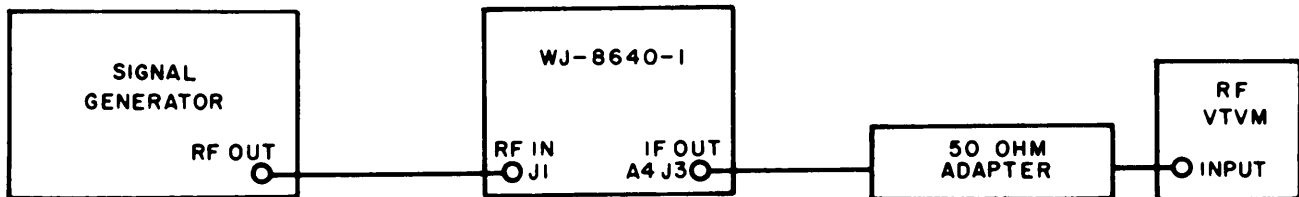


Figure 4-2. Test Setup, Image Rejection Circuit

- (2) Adjust the Receiver as follows: MODE: AM, RF GAIN: Maximum (fully CW), Tune Receiver: 80 MHz, Band (MHz): Low.
- (3) Set the signal generator to 80 MHz with an output level of -110 dBm.
- (4) Note the reading on the RF VTVM for a reference. Unit gain or signal level may be varied slightly to obtain a convenient reference on the RF VTVM.
- (5) Retune the signal generator to the image frequency of 100 MHz.
- (6) Increase the signal generator output level until the reference reading of step (4) is obtained on the RF VTVM.
- (7) Record the change in the signal generator output level (step 6 - step 4). The minimum difference should be 60 dB.

- (8) Set the signal generator for 250 MHz with an output level to -110 dBm. Select the HIGH BAND on the receiver; tune the receiver for 250 MHz and proceed with steps (4) through (7) | The difference should be a minimum of 50 dB.

4.6.3

IF BANDWIDTH AND CENTER FREQUENCY

- (1) Construct the circuit as shown in Figure 4-3.

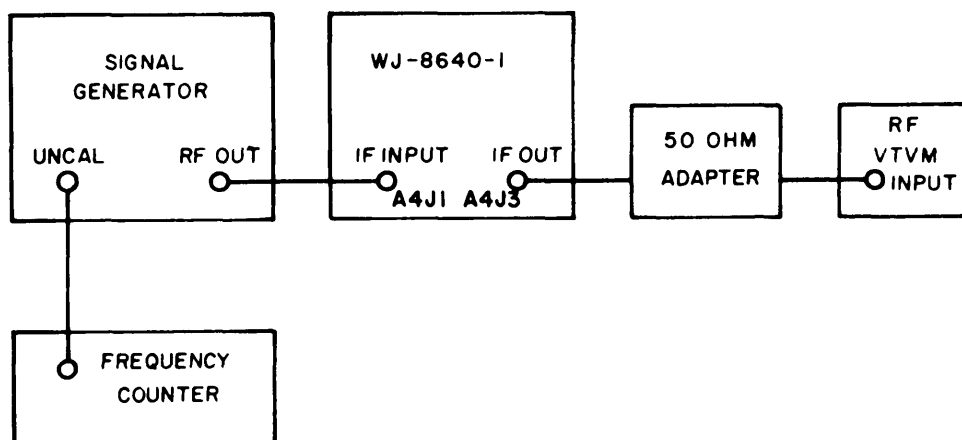


Figure 4-3. Test Setup, If Bandwidth and Center Frequency Circuit

- (2) Set the Receiver controls as follows: Maximum gain, MODE: AM, IF BANDWIDTH: 10 kHz.
- (3) Set the signal generator to 10 MHz and adjust its output for a convenient reference on the RF VTVM.
- (4) Increase the frequency of the signal generator, maintaining a constant output level, until the reading on the RF VTVM decreases 3 dB.
- (5) Record the frequency of the signal generator.
- (6) Decrease the frequency of the signal generator, passing through the IF center frequency, until the reading of the RF VTVM is again 3 dB less than the reference set in step (3).
- (7) Record the frequency of the signal generator.

- (8) Subtract the frequencies in steps (5) and (7). This is the 3 dB IF bandwidth. Its value should be between 9.0 to 11.0 kHz.
- (9) Record the center frequency. The value can vary between 9.9975 and 10.0025 MHz.
- (10) Readjust the signal generator to 10 MHz and select the 50 kHz as the IF BANDWIDTH.
- (11) Repeat steps (3) through (7).
- (12) Subtract the frequencies of steps (5) and (7). The resultant should range between 45 to 55 kHz.
- (13) Record the center frequency. The value should range between 9.9975 and 10.0025 MHz.
- (14) Set the signal generator 10 MHz and place the IF BW switch to 200 kHz.
- (15) Repeat step (11).
- (16) Subtract the frequencies of steps (5) and (7). The resultant should range between 180 and 220 kHz.
- (17) "Record the center frequency. This value should range between 9.990 and 10.010 MHz.

4.6.4 RF GAIN CONTROL RANGE

- (1) Construct the circuit as shown in Figure 4-4.

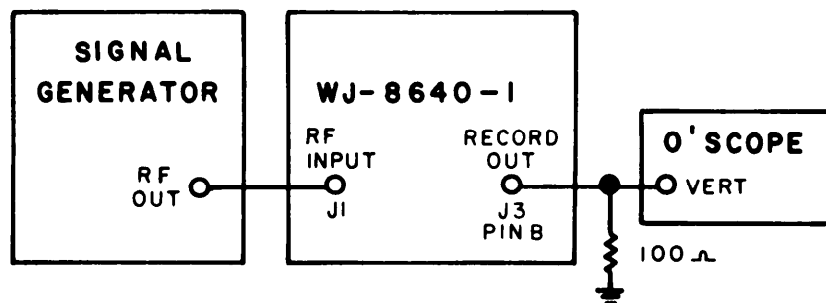


Figure 4-4. Test Setup, RF Gain Control Range Circuit

- (2) Set the receiver controls as follows; MODE: AM, IF BW: 10 kHz, tune the receiver to a tuned frequency of 70 MHz (LOW BAND).
- (3) Adjust the signal generator output to -107 dBm at 70 MHz modulated at 1 kHz; 50% and obtain a convenient reference on the scope.
- (4) Increase the signal generator output in steps of 10 dB, while returning the scope to the reference by using the RF GAIN control.
- (5) Record the RF GAIN control range. The minimum amount allowed is 60 dB.

4.6.5 DAFC RANGE

- (1) Set the tuner to the low end of band and record this frequency.
- (2) Lock the DAFC; then move the local oscillator slowly CCW, observing the counter. Discontinue moving the local oscillator when the counter quits correcting for the movement.
- (3) Unlock the DAFC and record this frequency.
- (4) Reset the tuned frequency to that recorded in step (1) above.
- (5) Lock the DAFC, then move the local oscillator slowly CW observing the counter. Discontinue moving the local oscillator when the counter quits correcting for the movement.
- (6) Unlock the DAFC and record this frequency.
- (7) The difference between steps (6) and (3) is the DAFC range.
- (8) Set the tuner to the high end of band and record this frequency. Repeat steps (2) through (7).

The DAFC range is a minimum of
0.1% of the tuned frequency.

4.6.6 FINE TUNING RANGE

- (1) Construct the circuit as shown in Figure 4-5.

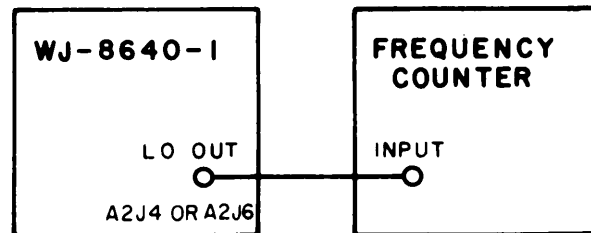


Figure 4-5. Test Setup, Fine Tuning Range

- (2) Set the tuned frequency to 20 MHz.
- (3) Set the fine tuning control to its full CCW position and record the frequency.
- (4) Set the fine tuning control to its full CW position and record the frequency.
- (5) The difference between steps (3) and (4) is the fine tuning range.
- (6) Set the tuned frequency to 80 MHz (low band) and proceed as above. The fine tuning range is a minimum of 0.5% of the tuned frequency.

4.6.7 DIRECT SUPPORT LEVEL PERFORMANCE TESTS

- (1) Test receiver.
- a) Energize receiver using DC power supply. Power may be connected to front panel power jack J-4 at 24 VDC or rear power plug J-6 at 12.6 VDC.
 - b) Using digital voltmeter check voltages Negative (-) lead connects to chassis ground positive lead to following test points (test points are located at bottom rear of chassis):
 - C7 = 9.2 to 10 VDC
 - C8 = -13.5 to -17 VDC
 - C9 = 13.5 to 17 VDC
 - C10 = 5.6 to 6.5 VDC
- (2) Test receiver gain in higher frequency.
- a) Set BAND MHz switch to 20-80 MHz setting.

- b) Adjust receiver TUNE knob until receiver frequency display indicates 40 MHz.
- c) Set IF BANDWIDTH switch to 50 KHz.
- d) Set the MODE SELECTOR switch to AM.
- e) Set DAFC lock switch in OFF position.
- f) RF GAIN control fully clockwise in AGC position.
- g) Connect RF VOLTMETER to J-3 (test point) on chassis deck of receiver (J-3 is located at center with receiver top side up).
- h) Connect RF signal generator to RF input jack (J 1) on front panel of receiver.
- i) Set RF signal generator to 40 MHz, output level of -100 dbm. RF signal generator should be outputting a continuous wave (CW) signal. The purpose of test is to verify gain of receiver. If RF voltmeter reads 50 millivolts or greater, gain is acceptable.

NOTE

Previous portion of test verified receiver gain in lower (20-80 MHz) frequency band. Next portion of test will verify receiver gain in upper (80-250 MHz) frequency band.

(3) Test receiver gain in lower frequency.

- a) Set up test equipment the same as in previous test.
- b) Set BAND MHz switch to 80-250 MHz setting.
- c) Adjust receiver TUNE knob until receiver frequency display indicates 150 MHz.
- d) Set RF signal generator to 150 MHz, output level of -100 dbm. RF voltmeter should read 50 millivolts or greater for acceptable receiver gain in upper band.
- e) Disconnect RF voltmeter.

(4) Test receiver audio in higher band.

- a) Connect oscilloscope to audio record jack on front panel of receiver for audio portion of test.
- b) Set oscilloscope to monitor DC volts, VOLT/DIVISION SET to 1, TIME/DIVISION to .5 milliseconds.
- c) Set RF signal generator to 150 MHz at -90 dbm, AM at 400 Hz 50%.

MAINTENANCE

- d) Adjust oscilloscope to observe a single sinewave with amplitude of 4 volts peak-to-peak.
 - e) Set IF BANDWIDTH switch to 10 KHz. Observe sinewave as IF BANDWIDTH switch is changed from 10 KHz to 50 KHz to 200 KHz. Sinewave should lose its sharpness, becoming more distorted.
- (5) Test receiver audio in lower band.
- a) Change receiver frequency and RF signal generator frequency to 40 MHz,
 - b) Set BAND MHz switch to 20-80 MHz. All other settings and connections remain the same.
 - c) Follow steps 4 d and 4 e above.
- (6) Test receiver in FM.
- a) Set receiver MODE switch to FM.
 - b) Set IF BANDWIDTH switch to 10 KHz.
 - c) Set RF signal generator to FM, 40 MHz -90 dbm, peak deviation of 3 KHz at 400 Hz.
 - d) oscilloscope should be adjusted to observe a single sinewave with an amplitude of 4 volts peak-to-peak.
 - e) Set IF BANDWIDTH switch to 50 KHz and RF signal generator to a peak deviation of 15 KHz.
 - f) Observe same sinewave seen in step 6 d above.
 - g) Set IF BANDWIDTH switch to 200 KHz and RF signal generator to a peak deviation of 60 KHz.
 - h) Observe same sinewave seen in step 6 d above.
 - i) Change receiver frequency display to 150 MHz.
 - j) Set BANDWIDTH MHz switch to 80-250 MHz.
 - k) Set RF signal generator to FM, 150 MHz -90 dbm, peak deviation of 3 KHz at 400 Hz.
 - l) Repeat steps 6 c through 6 h above.
- (7) Test receiver in USB/CW.
- a) Connect oscilloscope to AUDIO PHONES jack on front panel of receiver.

- b) Set receiver VOLUME control on front panel to maximum or fully clockwise.
 - c) Set SQUELCH control fully clockwise.
 - d) Set MODE switch to USB/CW.
 - e) Set RF signal generator for continuous wave (CW) 150 MHz -90 dbm.
 - f) Set RF GAIN knob to maximum manual position (not in AGC).
 - g) Set oscilloscope VOLTS/DIVISION control to 2.
 - h) Oscilloscope should be adjusted to observe a sine wave with amplitude of 10 volts peak-to-peak. As receiver frequency display is increased above 150 MHz, signal on scope should change as display is adjusted below 150 MHz. Scope should read zero (0).
- (8) Test receiver in LSB/CW.
- a) Set MODE switch to LSB/CW.
 - b) As receiver frequency display is adjusted below 150 MHz, sine wave on scope should change as it is adjusted above 150 MHz It should read zero (0).
 - c) Set BAND MHz to 20-80 MHz setting.
 - d) Follow steps 7 d through 7 h above using frequency on tuner display and RF signal generator of 40 MHz.
- (9) Replace unit cover.
- a) Place unit face down on front panel.
 - b) Place unit cover over unit chassis
 - c) Using 4 inch flat tip screwdriver, tighten 4 thumb screws, 2 on each side of front panel rear.

4.7

ALIGNMENT PROCEDURES

NOTE

Alignment procedures are not to be performed at the direct support maintenance level. Replacement assemblies and subassemblies are pre-aligned at the manufacturing plant. No further alignment is required upon installation.

In the following paragraphs are detailed descriptions of the alignment procedures for the required subassemblies. It is assumed that the receiver is in workable, if not aligned, condition.

4.7.1 TYPE 791794 DC-DC CONVERTER (A6)

(1) Construct the circuit as shown in Figure 4-6.

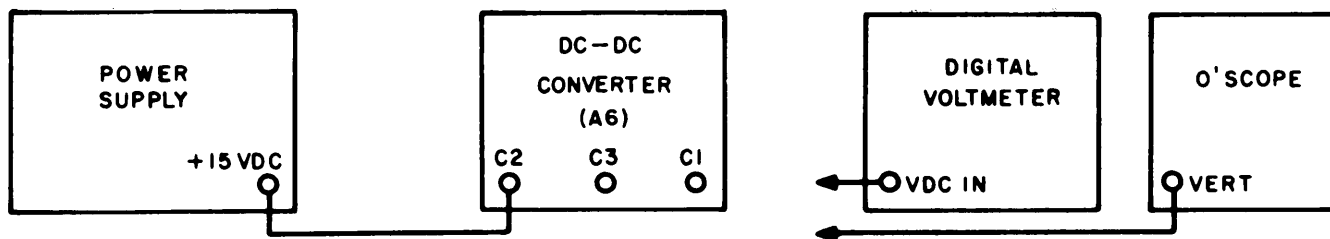


Figure 4-6. Test Setup, DC-DC Converter (A6) Alignment

- (2) Adjust the power supply for an output of +15 Vdc.
- (3) Connect the Digital Voltmeter (DVM) to C3.
- (4) Adjust potentiometer R14 for a reading on the DVM of +9.5 Vdc.
- (5) Reconnect the DVM to C1 .
- (6) Adjust potentiometer R12 until the DVM has a reading of +6.0 Vdc.
- (7) Connect the vertical probe of the oscilloscope to U3 pin 3.
- (8) Adjust potentiometer R18 until a symmetrical square wave response of approximately 9.5 V peak is obtained as an oscilloscope display.
- (9) Connect the DVM to C4 and C5 for readings of +15 Vdc and -15 Vdc respectively.
- (10) Reduce the input supply voltage to a level of +11.0 Vdc.

- (11) Adjust potentiometer R27 until the LED located on the receiver's front panel indicating POWER barely goes out. Adjust supply level for +11.1 Vdc and check that the LED is on again.

4.7.2 TYPE 791800-1 IF DEMODULATOR (A4)

- (1) Construct the circuit as shown in Figure 4-7.

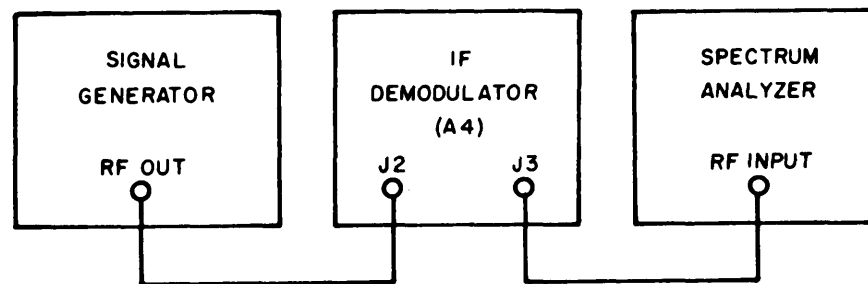


Figure 4-7. Test Setup, IF Demodulator (A4) Alignment

- (2) Adjust the Signal Generator for an output of 21.4 MHz.
- (3) Set the receiver controls as follows: RF GAIN - maximum manual (not AGC), IF BANDWIDTH - 200 kHz .
- (4) Tune the Spectrum Analyzer for a signal of 10 MHz .
- (5) Increase the Signal Generator's output level until a response is detected on the Spectrum Analyzer. (Note: The signal level could possibly be high depending upon the degree of misalignment).
- (6) Using the 10-pin extender card provided with the receiver; extend card A1.
- (7) Adjust L1 for a maximum response on the Spectrum Analyzer.
- (8) Remove card A1 from the extender and replace it in its normal position.

- (9) Extend card A3 (Gain BW Compensation Amplifier).
- (10) Adjust inductor L1 for a maximum response on the Spectrum Analyzer. Also adjust R13 for maximum gain.

NOTE

As the alignment of the IF Demodulator progresses, it will be necessary to continually reduce the input level to the module to prevent saturation of the active components.

- (11) Remove card A3 from extender and replace in its normal position.
- (12) Extend card A5 (10 MHz Amplifier subassembly).
- (13) Adjust inductor L1 for a maximum response on the Analyzer.
- (14) Remove card A5 from the extender and replace in its normal position.
- (15) Extend card A8 (10 MHz Amplifier Subassembly).
- (16) Repeat step 13.
- (17) Remove card A8 from the extender and replace in its normal position.
- (18) Extend card A6 (AM Detector/Buffer).
- (19) Adjust C 18 for a maximum response on the Analyzer.
- (20) Connect an oscilloscope to pin 2 of A6.
- (21) Using the signal generator, apply a 1 kHz signal with 50% modulation.
- (22) Adjust C4 for a maximum dc output at pin 2.
- (23) Repeat steps 1 through 20 until interaction between the alignable components is negligible.

4.7.2.1 Type 791785 Product Detector (A4A7)

- (1) Construct the circuit as shown in Figure 4-8.

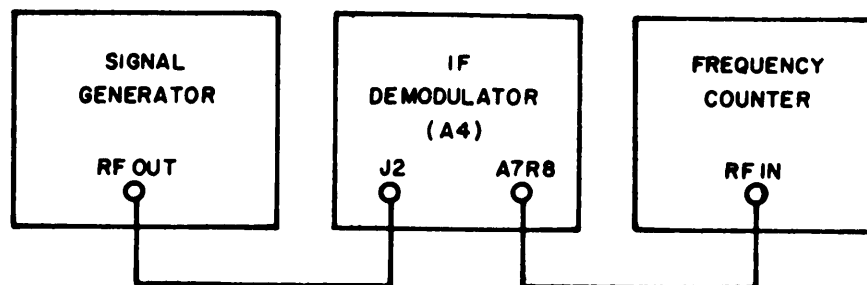


Figure 4-8. Test Setup, Product Detector (A4A7) Alignment

- (2) Set the receiver's mode for USB/CW or LSB/CW.
- (3) Connect the Frequency Counter across R8.
- (4) Adjust C13 for a frequency reading of 10 MHz.

4.7.2.2 Type 791802 Gain BW Compensation Amplifier (A4A3)

- (1) Construct the circuit as shown in Figure 4-9.
- (2) Adjust the Signal Generator for a 10 MHz carrier frequency, 1 kHz audio @ 50% modulation frequency and a signal level at -74 dBm. On the receiver, set the bandwidth for 200 kHz and the gain to AGC.
- (3) Using the card extender, extend card A3.
- (4) Adjust R13 for an approximate 1.2 Vdc reading on the DVM.
- (5) Measure and record the reading of the AC VTVM with the input signal present. The reading should be a maximum of 300 mV.

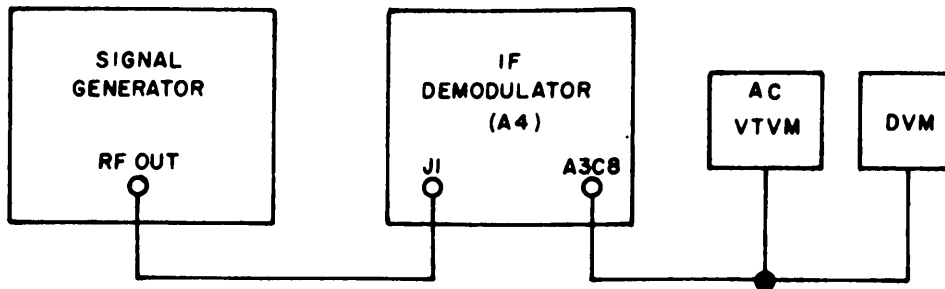


Figure 4-9. Test Setup, Gain Adjustable Ampl. & Diode Sw. (A4A3) Alignment

4.7.2.3 Type 794021 21.4/10 MHz Converter (A4A1)

- (1) Construct the circuit as shown in Figure 4-10.
- (2) Using the card extender, extend card A4A1 (21.4/10 MHz Converter).
- (3) Select the Band Switch on the receiver's front panel to HIGH.
- (4) Connect Frequency Counter to junction of capacitors C10-C11.
- (5) Connect the Signal Generator to J2 on A4.
- (6) Set the Signal Generator for an output frequency of 21.4 MHz. Set level to -10 dBm.
- (7) Adjust variable capacitor A1C13 for a counter reading of 31.4 MHz.
- (8) Connect counter to output of board and check that the frequency is 10 MHz \pm 100 Hz.

NOTE

If the frequency in step 7 is unobtainable it may be necessary to change the value of C12.

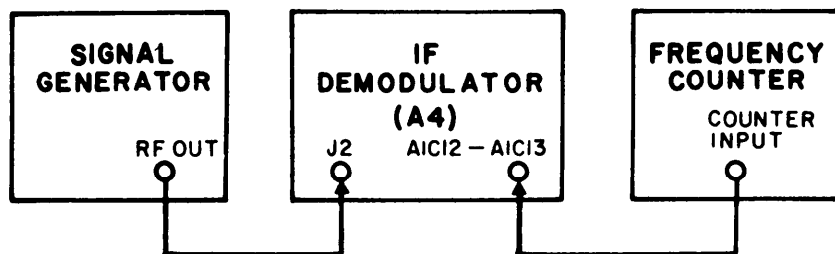


Figure 4-10. Test Setup, 21.4/10 MHz Converter Subassembly (A4A1) Alignment

4.7.3 TYPE 791817 AGC/SQUELCH (A5)

- (1) Construct the circuit as shown in Figure 4-11.
- (2) Set Receiver controls as follows: GAIN-AGC, MODE-AM, BAND-LOW (within Tuner's range) , BANDWIDTH- 10 kHz .
- (3) Using the 22-pin extender card, extend the AGC/SQUELCH card (A5).

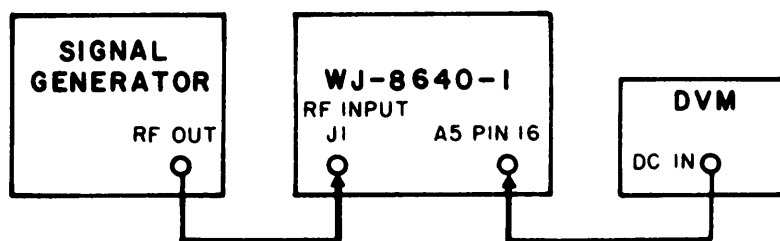


Figure 4-11. Test Setup, AGC/Squelch (A5) Alignment

- (4) Tune to a frequency within the Receiver's Tuner range on the Signal Generator. Adjust the input signal for a level of -107 dBm.

- (5) Tune the receiver to the frequency as used in step 4.
- (6) Measure the output level on the DVM.
- (7) Increase the input signal level 30 dB.
- (8) Adjust resistor R16 until the reading of the DVM begins to increase. (Threshold level).

4.7.4 TYPE 791784 FM DISCRIMINATOR (A?)

- (1) Construct circuit as shown in Figure 4-12.
- (2) Set the Sweep Generator for a center frequency of 10 MHz, sweep width of 300-400 kHz and a signal level of 20 mV.

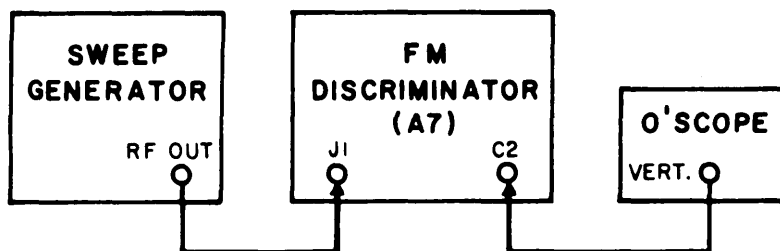


Figure 4-12. Test Setup, FM Discriminator (A7) Alignment

- (3) Adjust C12 and C17 for a typical "S" curve response (centered at 10 MHz). A typical response is shown in Figure 4-13.

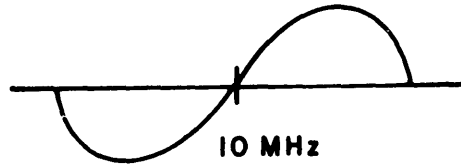


Figure 4-13. Typical Response, FM Discriminator Output

4.8 SUBASSEMBLY REMOVAL, REPAIR AND REPLACEMENT

All of the receiver assemblies are mounted in such a way as to permit easy accessibility/removal. Before a subassembly is removed, any coaxial cable connections or plug assemblies must be resoldered or disconnected. Repair procedures are straightforward and conventional observing the usual precautions regarding temperature on semiconductors and damage to circuit patterns on boards. Subassemblies and piece parts requiring resoldering are listed in the following subparagraphs.

4.8.1 BATTERY PACK JACK (J6) REMOVAL

The battery pack jack is removed through the rear of the rear panel by unscrewing each securing screw and resoldering the jacks 1 white wire.

4.8.2 SIGNAL STRENGTH METER (M1) REMOVAL

The signal strength meter is removed through the front panel by unscrewing the large knurled nut on the rear of the meter and resoldering its 1 black wire and one black/white wire.

4.8.3 BATTERY TEST SWITCH (S6) REMOVAL

The battery test switch is removed through the rear of the front panel by removing the switches securing nut on the front panel and resoldering the switches yellow and blue wires.

4.8.4 BATTERY CHECK LAMP (CR1) REMOVAL

The battery check lamp is removed through the rear of the front panel by unscrewing each lamp's securing screws on the front panel and desoldering the lamp boards 1 orange wire.

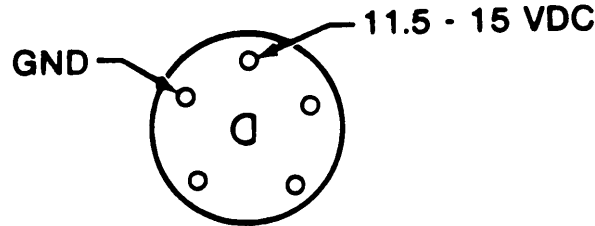
4.8.5 RECORD CONTROL (R11) REMOVAL

The RECORD control is removed through the bottom chassis by unscrewing its 1 nut and resoldering its 2 wires.

4.8.6 BATTERY PACK PLUG (A9P1) REMOVAL

The battery pack plug is removed from the battery pack by unscrewing each securing screw, sliding the plug out and resoldering the 3 white wires.

**BATTERY PACK
PLUG P1**



4.8.7 SPEAKER CABLE AND PLUG (A10P1) REMOVAL

The speaker cable and plug are removed by unscrewing the 4 Phillips screws and resoldering the following wires:

| <u>Solder Point</u> | <u>Wire Color</u> |
|---------------------|-------------------|
| E1 | Black |
| E2 | White |
| E3 | Green |

4.8.8 SPEAKER (LS1) REMOVAL

The speaker is removed from the speaker panel by unscrewing its 4 Phillips screws and resoldering the following wires:

| <u>Solder Point</u> | <u>Wire Color</u> |
|---------------------|-------------------|
| E4 | white |
| E5 | White |

4.8.9 AUDIO POWER AMPLIFIER BOARD (A10A1) REMOVAL

The audio power amplifier board is removed by unscrewing its 4 Phillips screws and resoldering the following wires:

| <u>Solder Point</u> | <u>Wire Color</u> |
|---------------------|-------------------|
| E1 | Black |
| E2 | White |
| E3 | Green |
| E4 | White |
| E5 | White |

4.8.10 DISPLAY BOARD (A3A1A1) REMOVAL

The display board is removed by unscrewing each securing screw and resoldering the 15 blue wires at solder points E27 to E41.

4.8.11 COUNTER BOARD (A3A1) REMOVAL

The counter board is removed by unscrewing each securing screw and resoldering the following wires:

| <u>Solder Point</u> | <u>Wire Color</u> |
|---------------------|--------------------|
| E3 | Green |
| E4 | Black/White |
| E2 | Yellow |
| E1 | Orange |
| E15 | Black/Blue/White |
| E16 | Black/Green/White |
| E7 | White/Gray |
| E22 | Black (2) |
| E6 | Orange/White |
| E26 | Brown/Purple/White |
| E25 | Blue/White/Purple |
| E17 | Brown(2) |
| E5 | Brown/White |
| E11 | White/Green |
| E13 | Green/Orange/White |
| E12 | Brown/Green/White |
| E9 | Coax-Shield |
| E8 | Coax-Core |
| E14 | Brown |
| E24 | Black |
| E20 | Red/White |
| E18 | Purple/White |
| E19 | White/Blue |
| E21 | White |
| E23 | Blue |

4.8.12 WIDEBAND AMPLIFIER BOARD (A3A2) REMOVAL

The wideband amplifier board is removed by unscrewing each securing screw and resoldering the following wires:

| <u>Solder Point</u> | <u>Wire Color</u> |
|---------------------|------------------------|
| E11 | Brown/Blue/White |
| E12 | Brown |
| E5 | White/Yellow |
| E3 | White/Brown |
| E4 | Orange/White |
| E6 | White/Green |
| E7 | White/Green/Brown |
| E8 | White/Orange/Green |
| E14 | White/Brown/Orange (2) |
| E13 | White/Purple/Blue (2) |
| E15 | White/Brown/Purple (2) |
| E9 | Coax-Core |
| E10 | Coax-Shield |

Courtesy of <http://BlackRadios.terryo.org>

Table 4-1. Type WJ-8640-1 Direct Support Troubleshooting Chart

| SYMPTOM | TROUBLESHOOTING PROCEDURE PAGE |
|---|--------------------------------------|
| POWER lamp that does not light. | 4-25 |
| No audio and no signal indication on SIGNAL STR meter. | 4-37 |
| No audio and no signal indication on SIGNAL STR meter when high band is selected. | 4-93 |
| No audio and no signal indication on SIGNAL STR meter when low band is selected. | 4-111 |
| No audio and no signal indication on SIGNAL STR meter in one or two IF BANDWIDTH (kHz) positions. | 4-131 |
| No audio and no signal indication on SIGNAL STR meter when USB/CW or LSB/CW is selected. | 4-143 |
| No audio and no signal indication on SIGNAL STR meter when AM is selected. | 4-155 |
| No audio and no signal indication on SIGNAL STR meter when FM is selected. | 4-163 |
| No audio when speaker assembly is used. | 4-171 |
| FREQUENCY MHz display that does not light. | 4-183 |
| FREQUENCY MHz display that changes frequency when DAFC LOCK switch is set to LOCK position. | 4-195 |
| FREQUENCY MHz display that locks at a preset frequency. | 4-207 |
| FREQUENCY MHz display that has unstable digits. | 4-221 |

Courtesy of <http://BlackRadios.terryo.org>

POWER LAMP THAT DOES NOT LIGHT

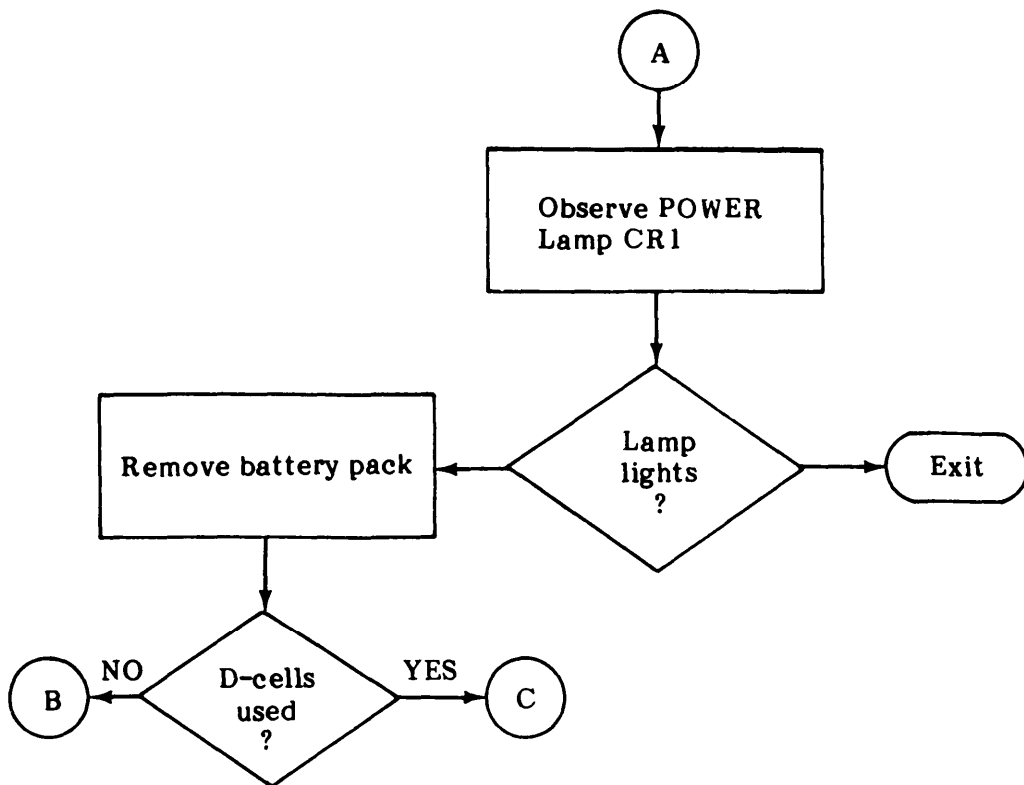
INITIAL SETUP

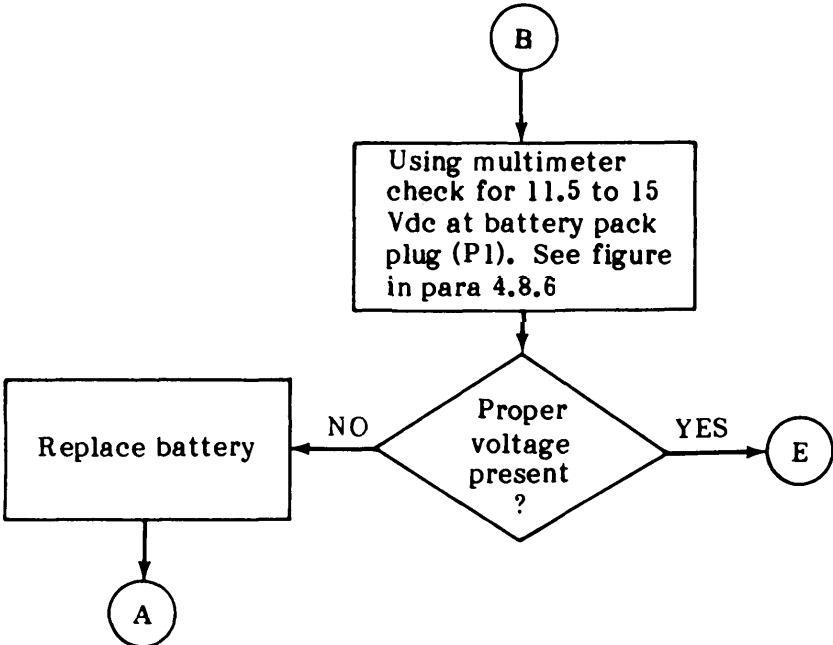
| | |
|-----------------------------|------------------|
| <u>Test Equipment</u> | |
| Multimeter | AN/PSM-45 |
| Test Lead Set | Simpson 00577 |
| <u>Tools</u> | |
| 4 Inch Flat Tip Screwdriver | 5120-00-222-8852 |
| <u>Replacement Parts</u> | |
| Battery | BA-4386/PRC-25 |
| D-Cells | BA-30 |
| Battery Pack Fuse (F1) | MDL-3/4 |
| Plug (P 1) | 103-1 |
| Jack (J6) | GC075 |
| Receiver Fuse (F1) | MDL-3/4 |
| Battery Test Switch (S6) | 30-1 |
| DC-DC Converter (A6) | 791794 |
| Power Lamp (CRI) | 5082-4860 |
| <u>Equipment Condition</u> | |
| Power switch (S7) set to ON | |

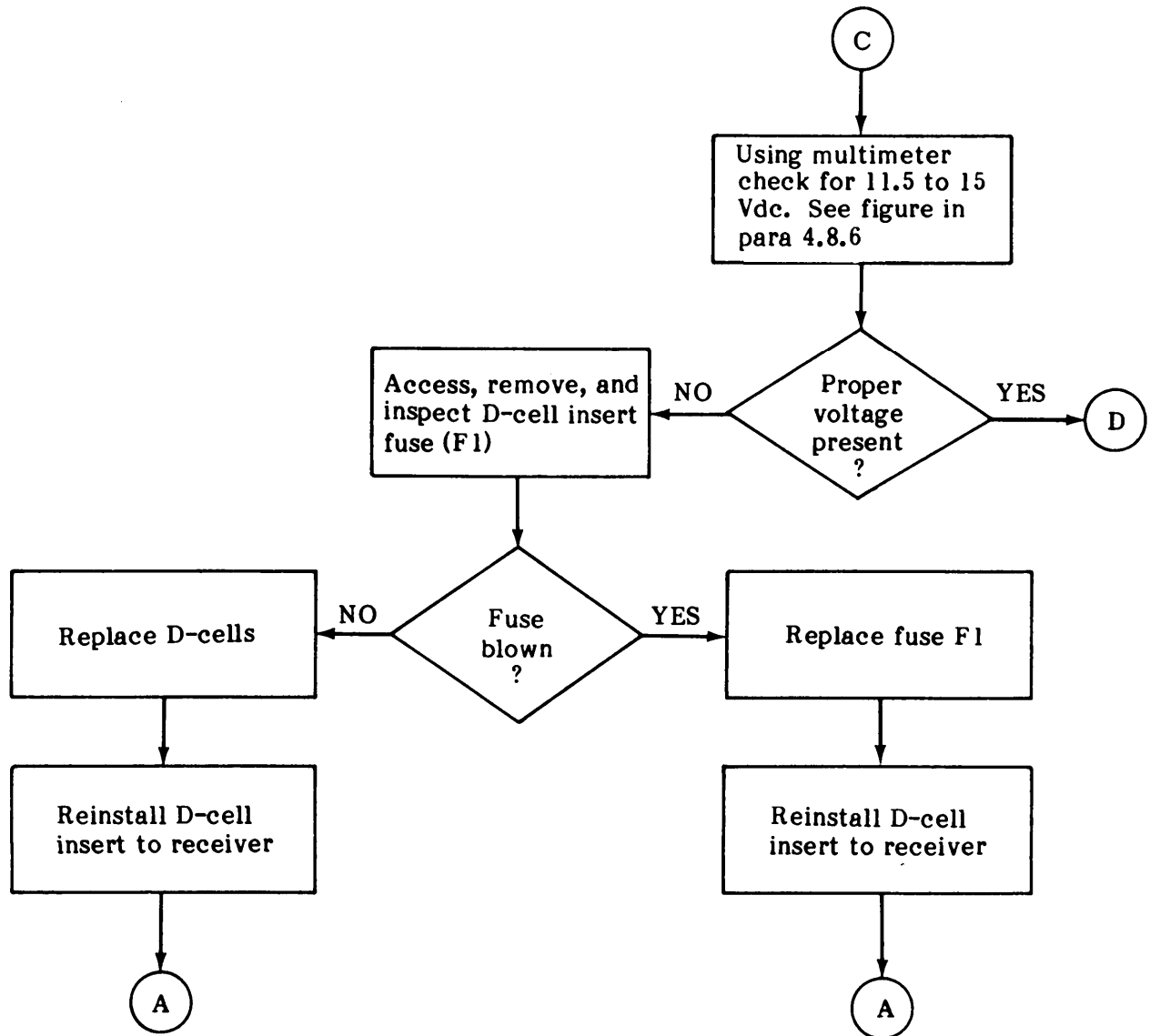
NOTE

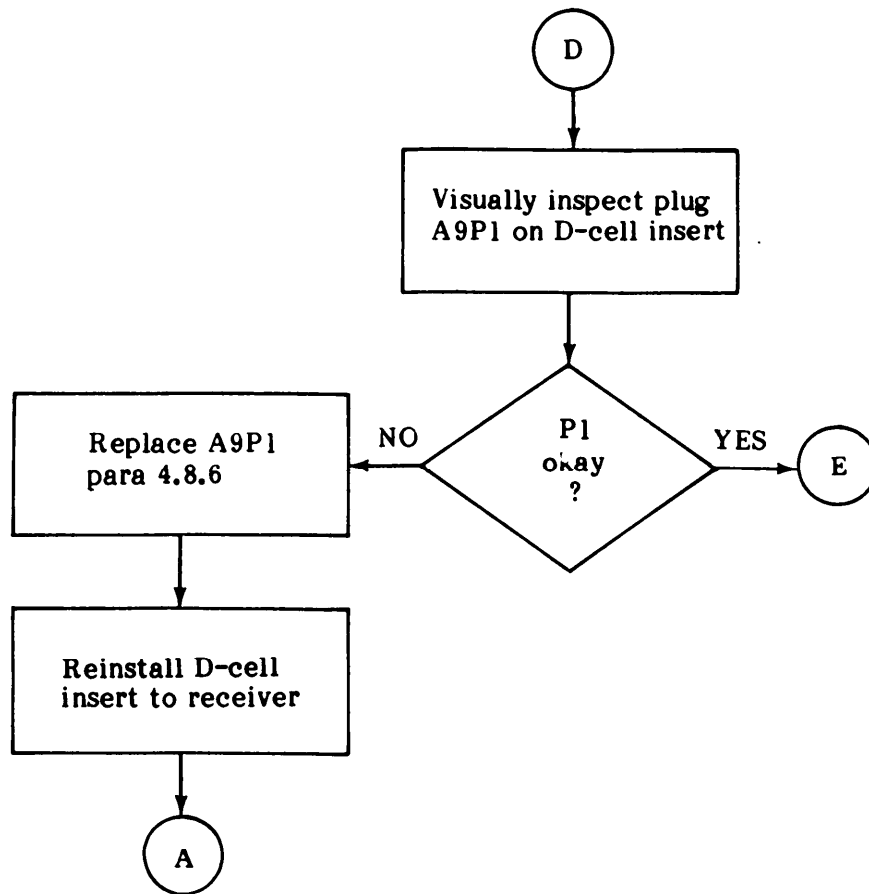
Minimum of 30 minutes warm-up time is required prior to starting troubleshooting procedures.

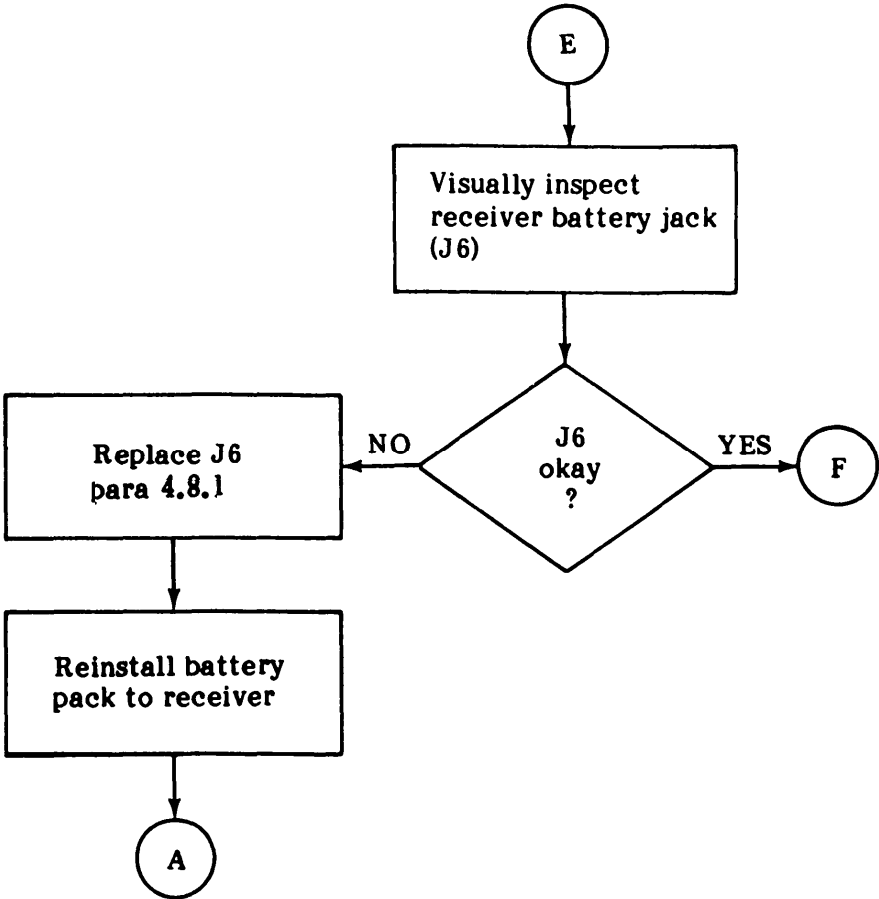
Courtesy of <http://BlackRadios.terryo.org>

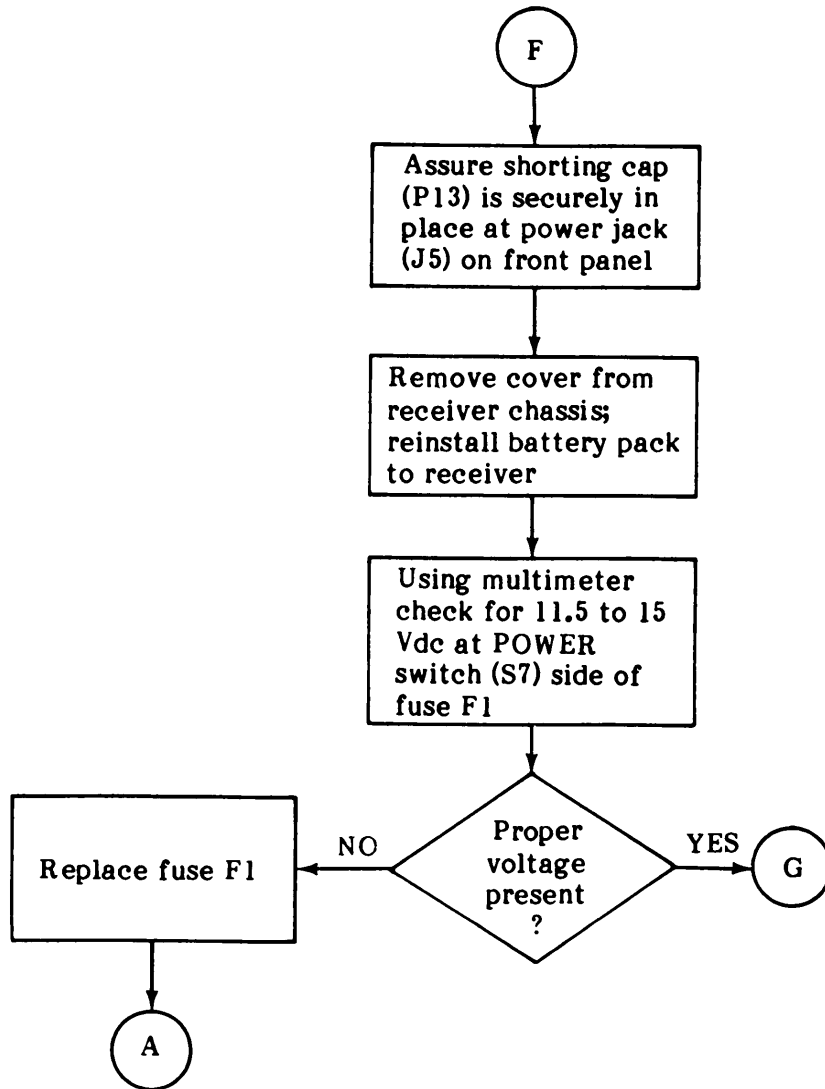


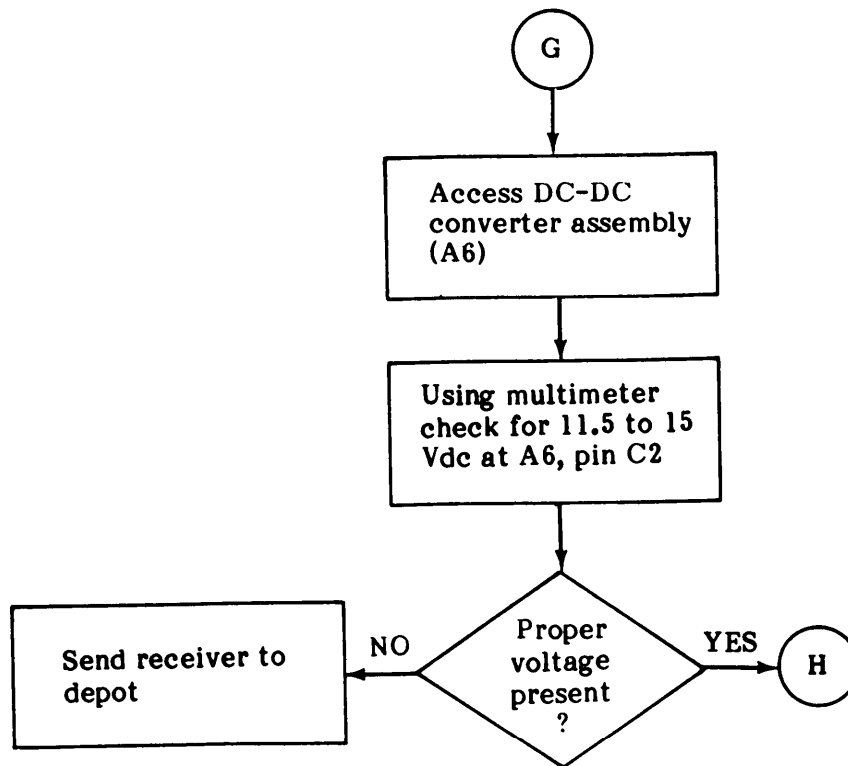


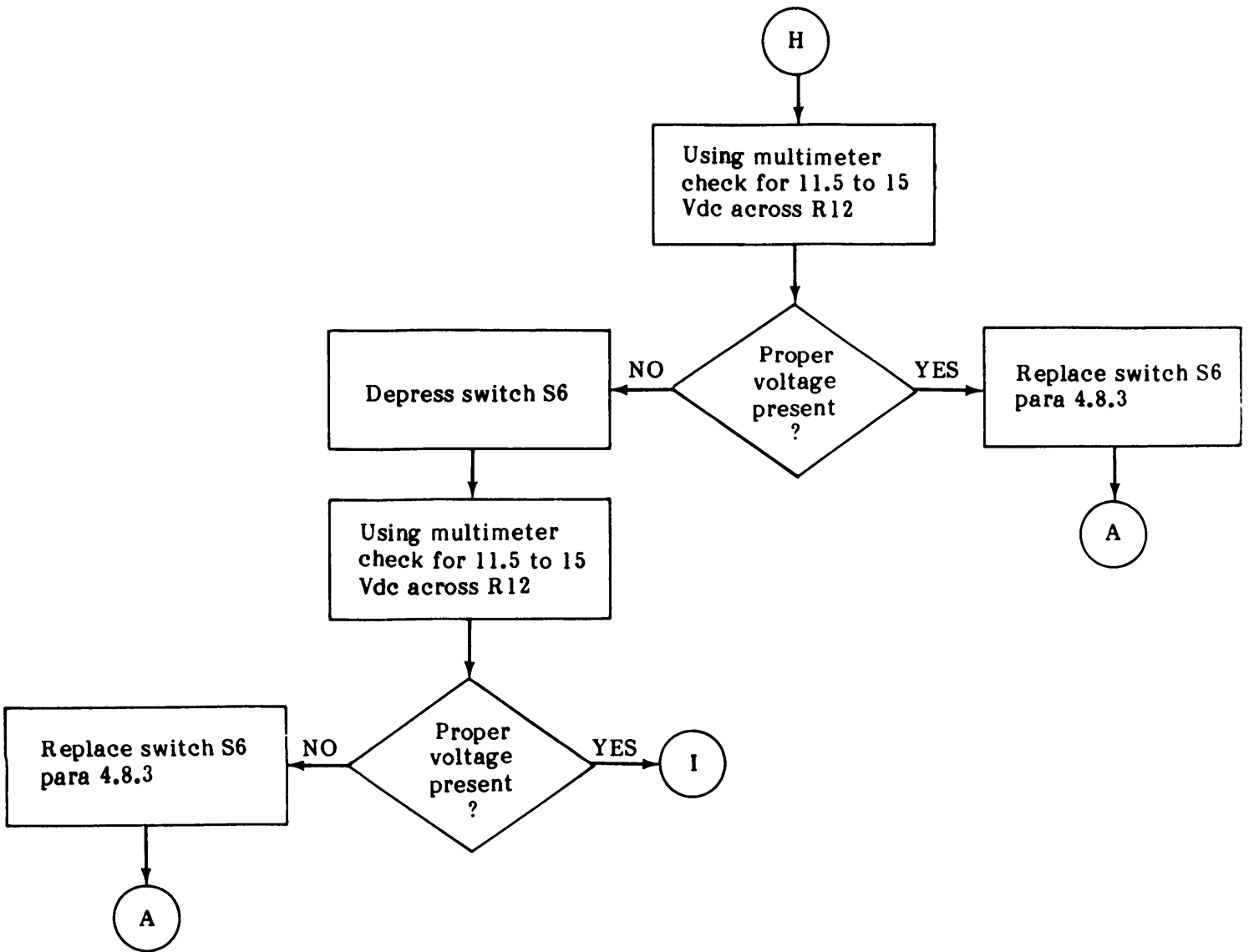


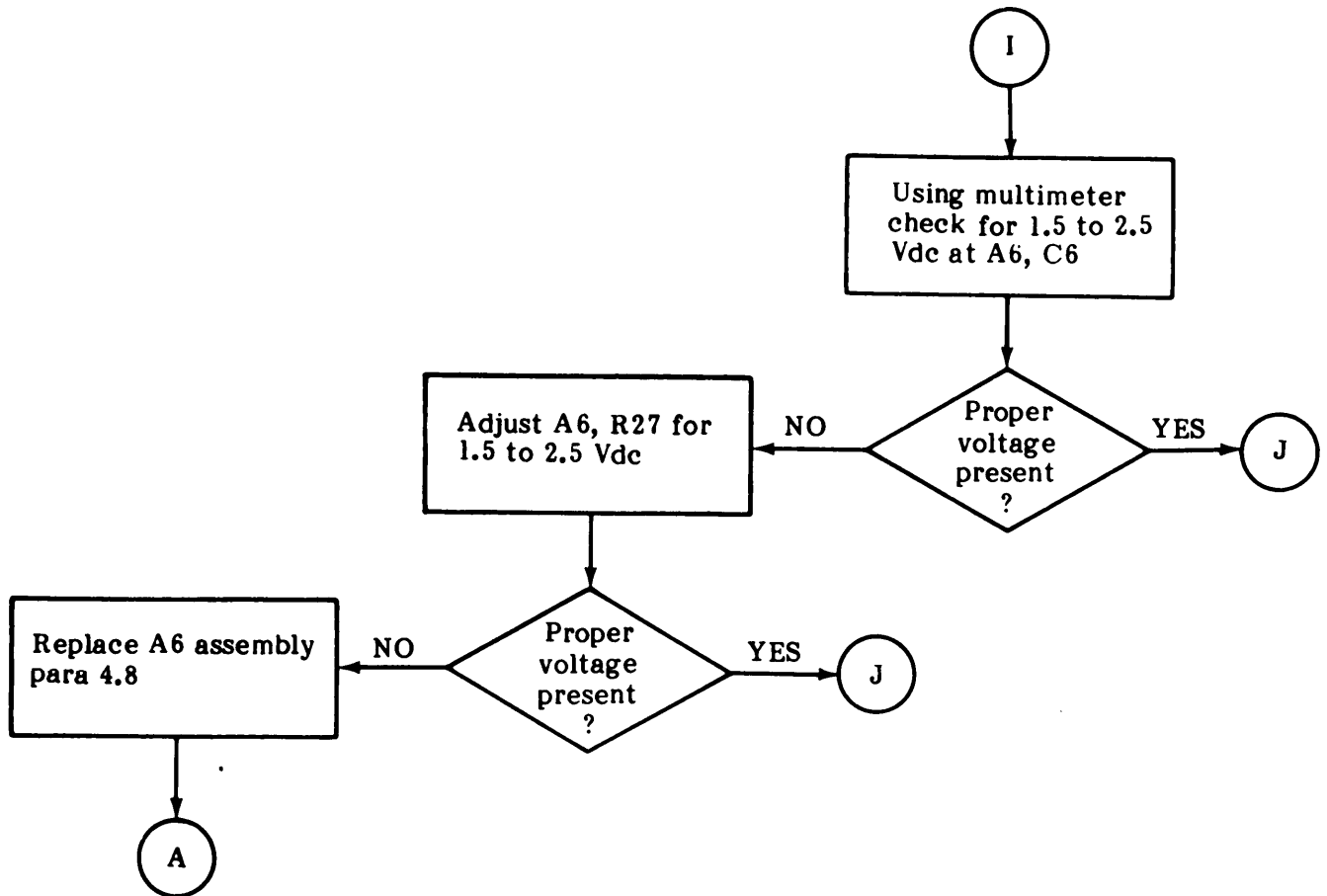


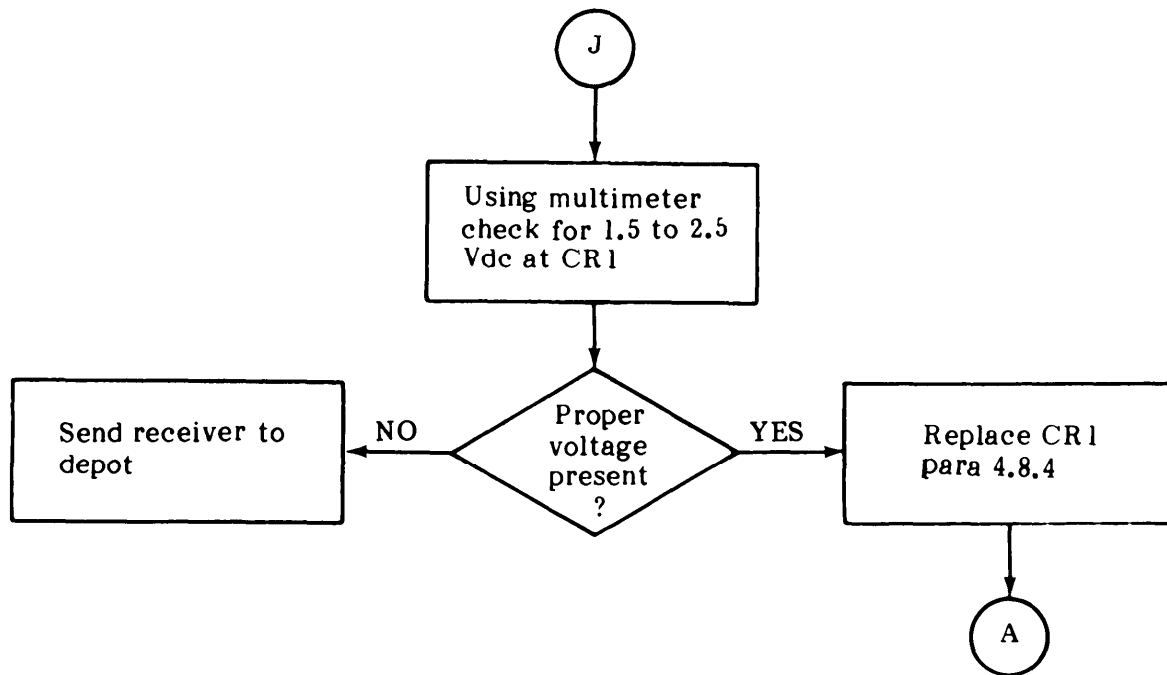












NO AUDIO AND NO SIGNAL INDICATION ON SIGNAL STR METER

INITIAL SETUPTest Equipment

| | |
|---------------------------------|--|
| Multi meter | AN/PSM-45 |
| Test Lead Set | Simpson 00577 |
| Signal Generator | SG-1112(V) l/u w/options 001, 002 and 003 |
| Cable, RF, 50 ohms, 4', BNC-BNC | HP 10503A |
| RF Voltmeter | Boonton 92C |
| High Frequency Probe | Boonton 91-12F |
| 50 ohm Adapter | Boonton 91-8B |
| Power Supply | PP-6547/U |

Tools

| | |
|-----------------------------|-------------------|
| 4 Inch Flat Tip Screwdriver | 51200-00-222-8852 |
| No. 1 Phillips Screwdriver | 51200-00-240-8716 |
| 7/32 Inch Open End Wrench | 51200-00-132-0486 |
| Card Extender | 791212 |

Replacement Parts

| | |
|---------------------------------------|--|
| DC-DC Converter (A6) | 791794 |
| Cable (W1) | 17300-148-1 |
| Antenna Switch (A1) | 791783 |
| Cable (W2) | 17300-148-2 |
| Tuner (A2) | TN-584/GRR-8 (V), TN-585/GRR-8(V) or TN-586/GRR-8(V) |
| Cable (W4) | 17300-148-4 |
| 21.4-10 MHz Converter (A4A1) | 794485-1 |
| Cable (W?) | 17300-148-7 |
| Cable (W3) | 17300-148-3 |
| Cable (W5) | 17300-148-5 |
| 10 MHz Amplifier (A4A8) | 791804 |
| GAIN BW Compensation Amplifier (A4A3) | 791802 |
| IF Filters and Diode Switches (A4A4) | 791803-1 |
| 10 MHz Amplifier (A4A5) | 791804 |
| Audio/Record Amplifier (A8) | 7464 |

Equipment Condition

POWER switch (S7) set to ON
 BAND (MHz) switch (S8) set to HIGH BAND
 Receiver tuned to 150 MHz
 MODE switch (S5) set to AM
 RF GAIN (R5) fully clockwise (not in AGC)
 VOLUME control (R10) set to mid-range
 IF BANDWIDTH switch (S4) set to 50 kHz
 Front cover speaker connected to J4
 Receiver cover removed

Signal generator set to 150 MHz CW @-30dbm
Signal generator connected to RF IN (J1)
RF voltmeter referenced to signal generator and set to read-15dbm
RF voltmeter connected to SM OUT (J2)
Power supply set to 24 Vdc
Power supply connected to J5
WJ-9121 [TN-584/GRR-8(V)] Tuner installed

NOTE

Level readings given reflect the use of the Boonton 91-8B 50 OHM adapter for all cables and connector measurements and the use of the Boonton 91-12F probe with tip at all circuit board measurements

Minimum of 30 minutes warm-up time is required prior to starting troubleshooting procedures.

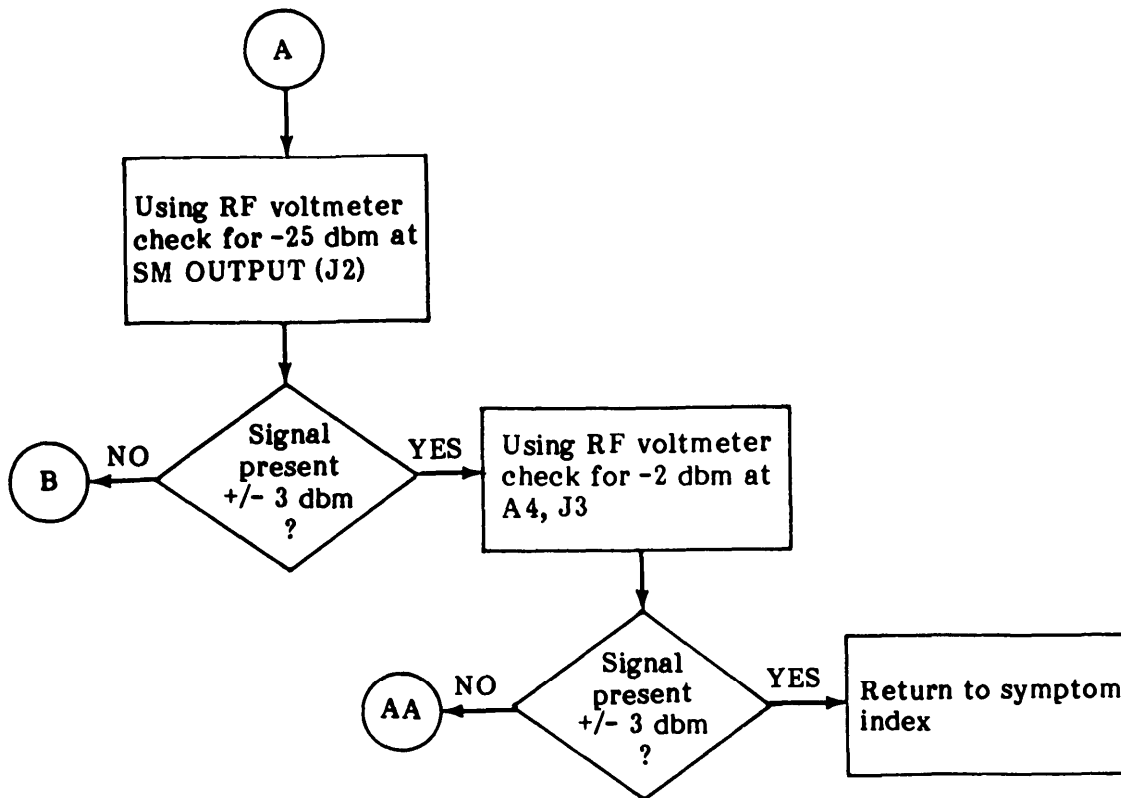
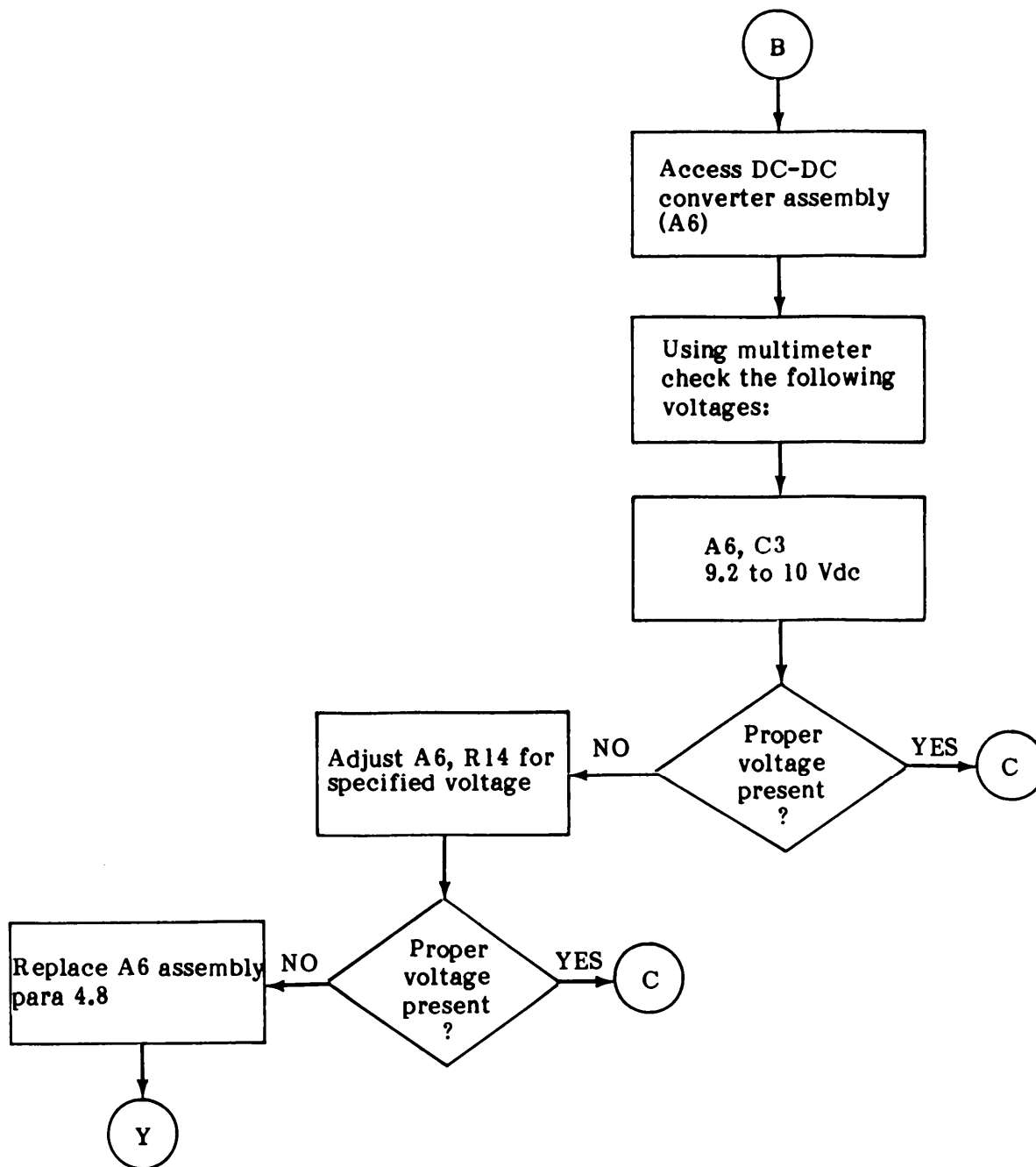
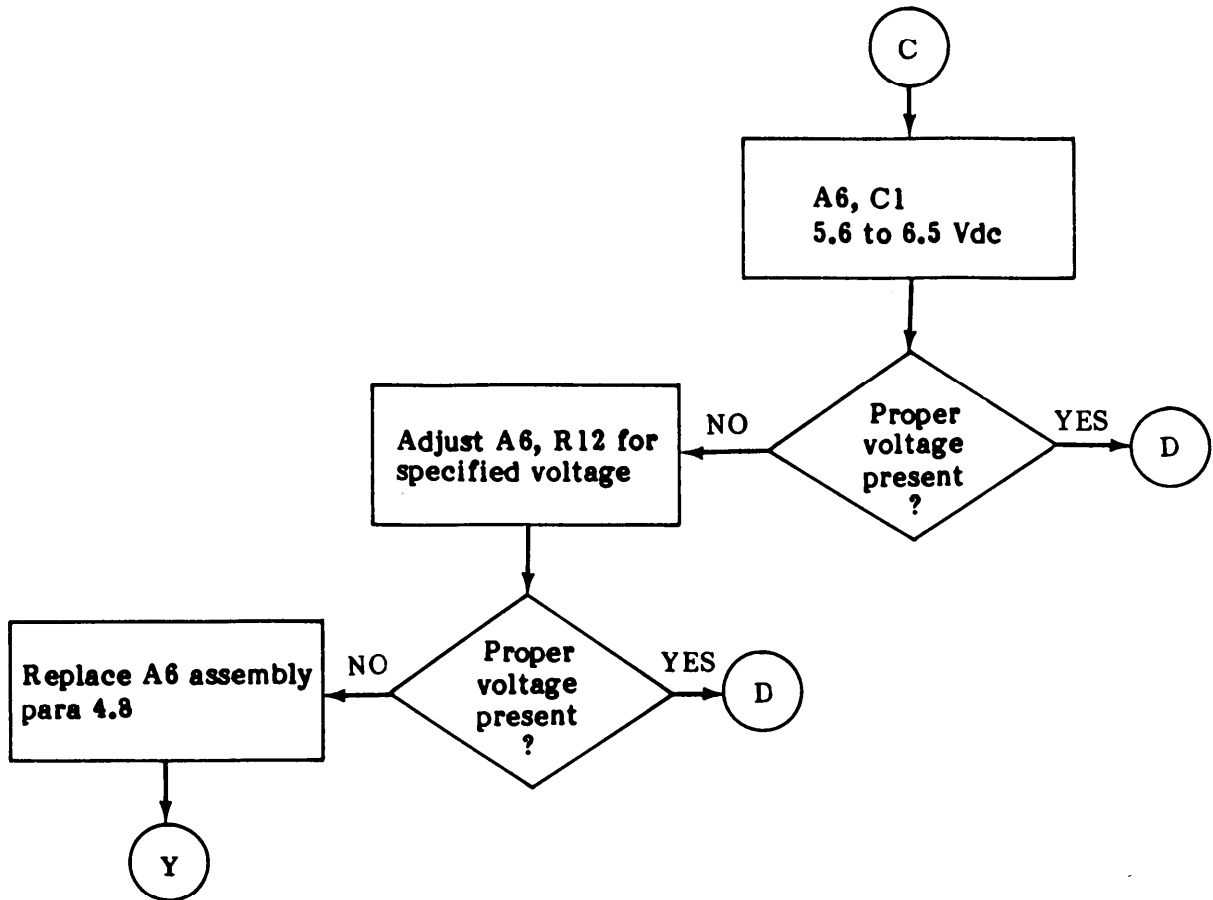
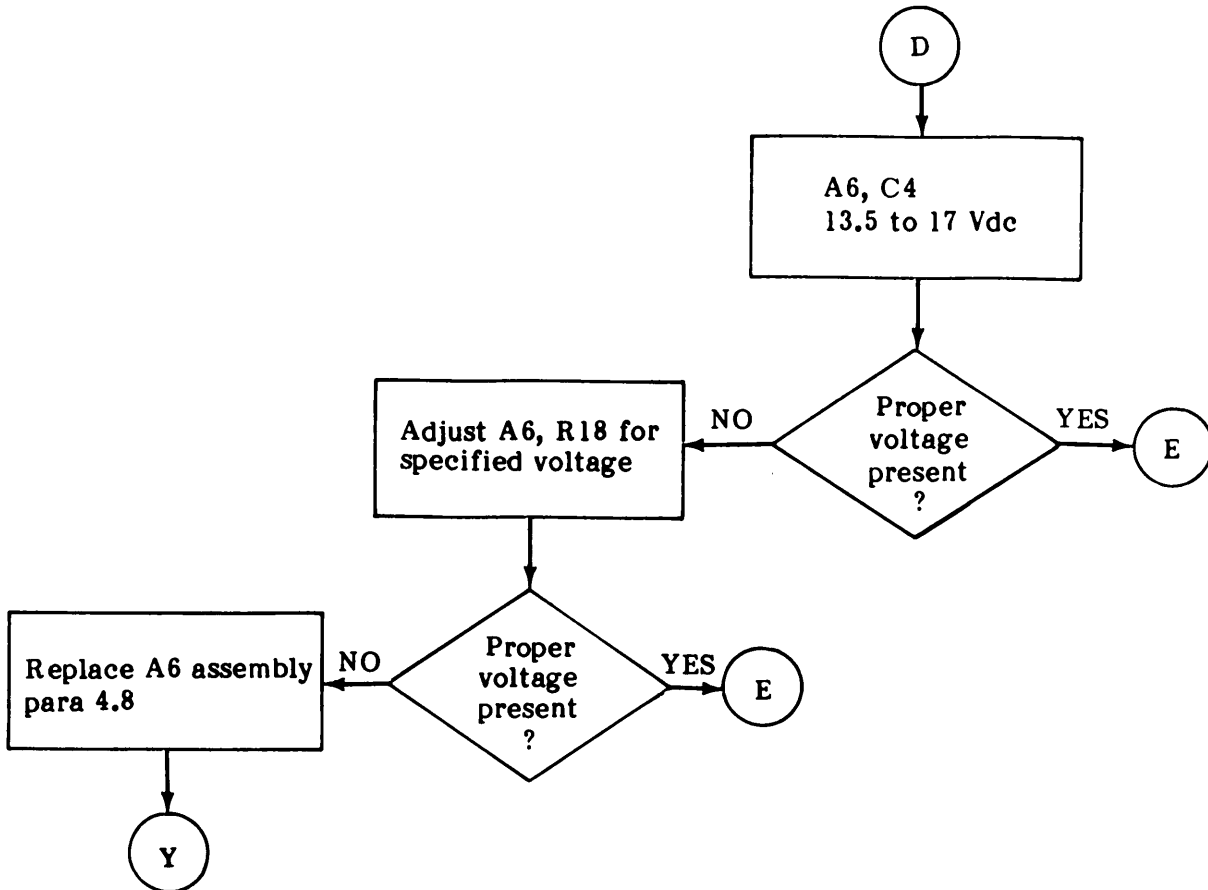


TABLE 4-1







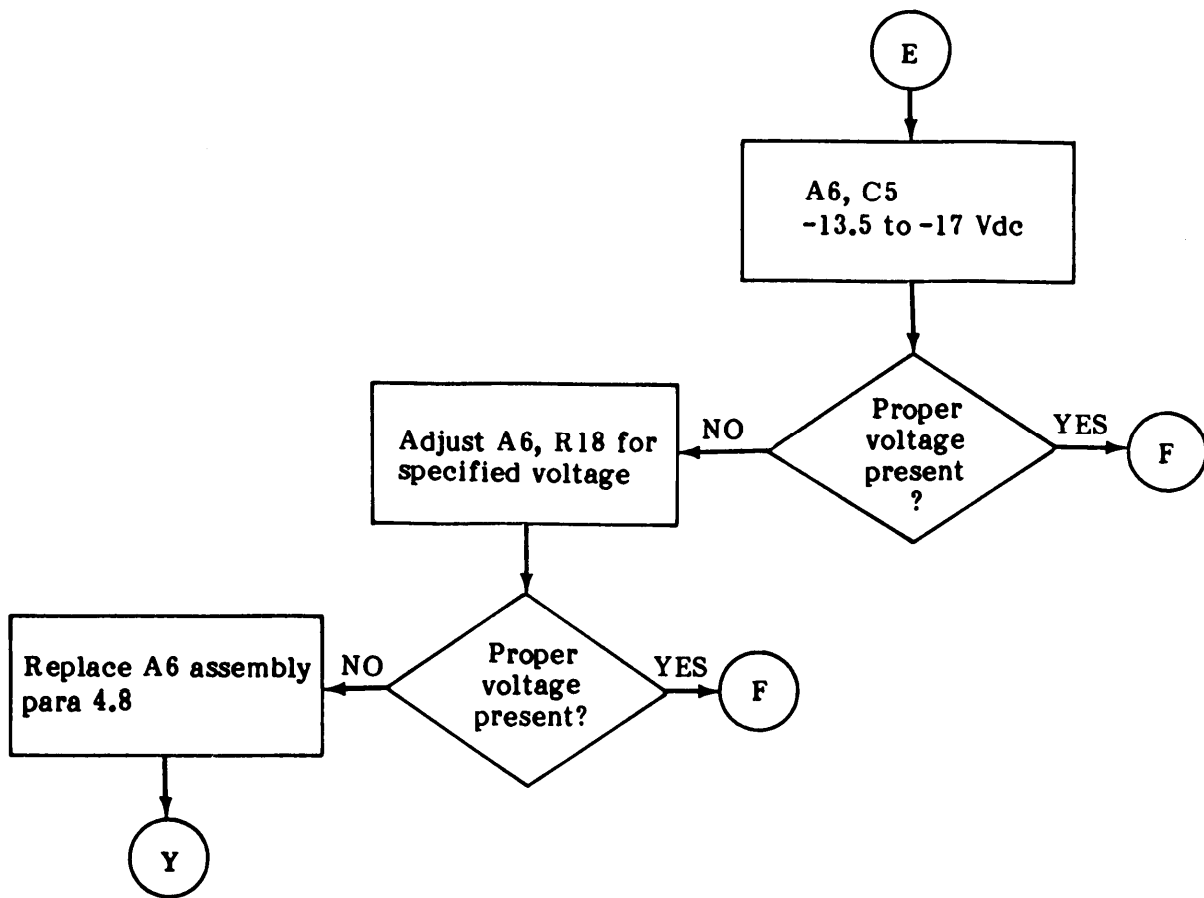
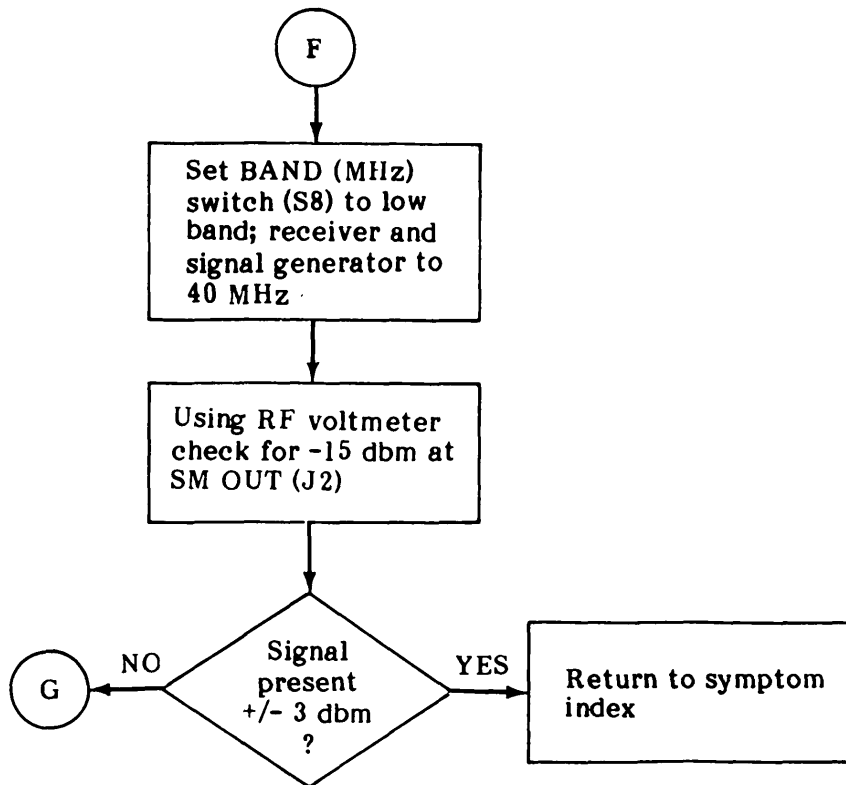
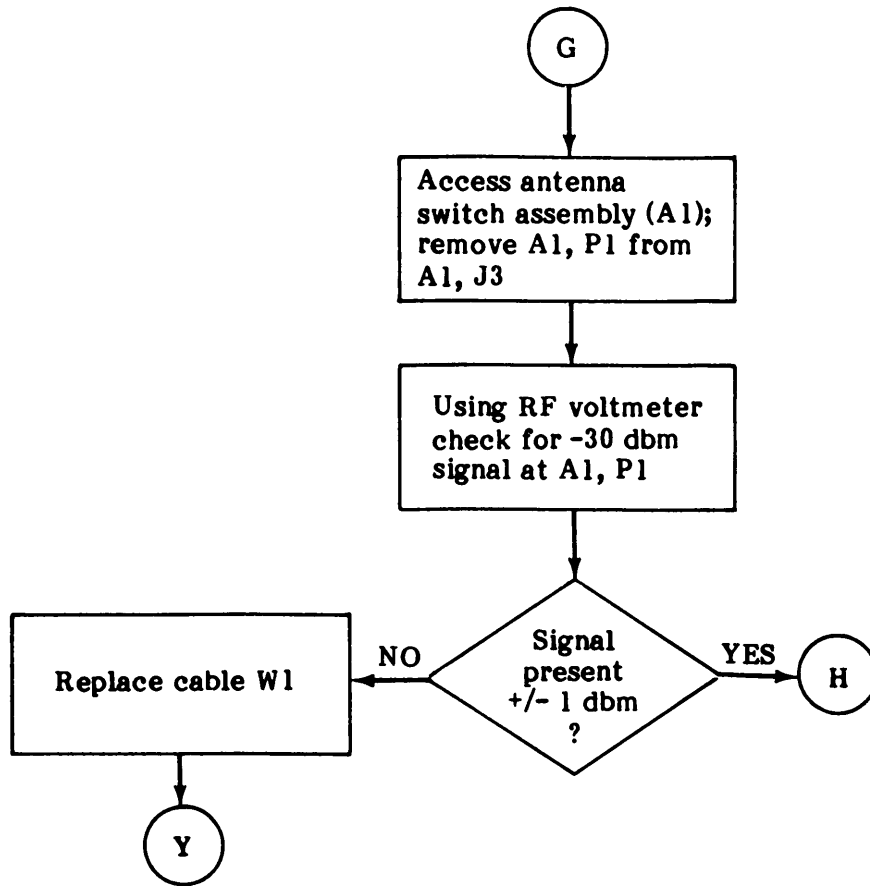
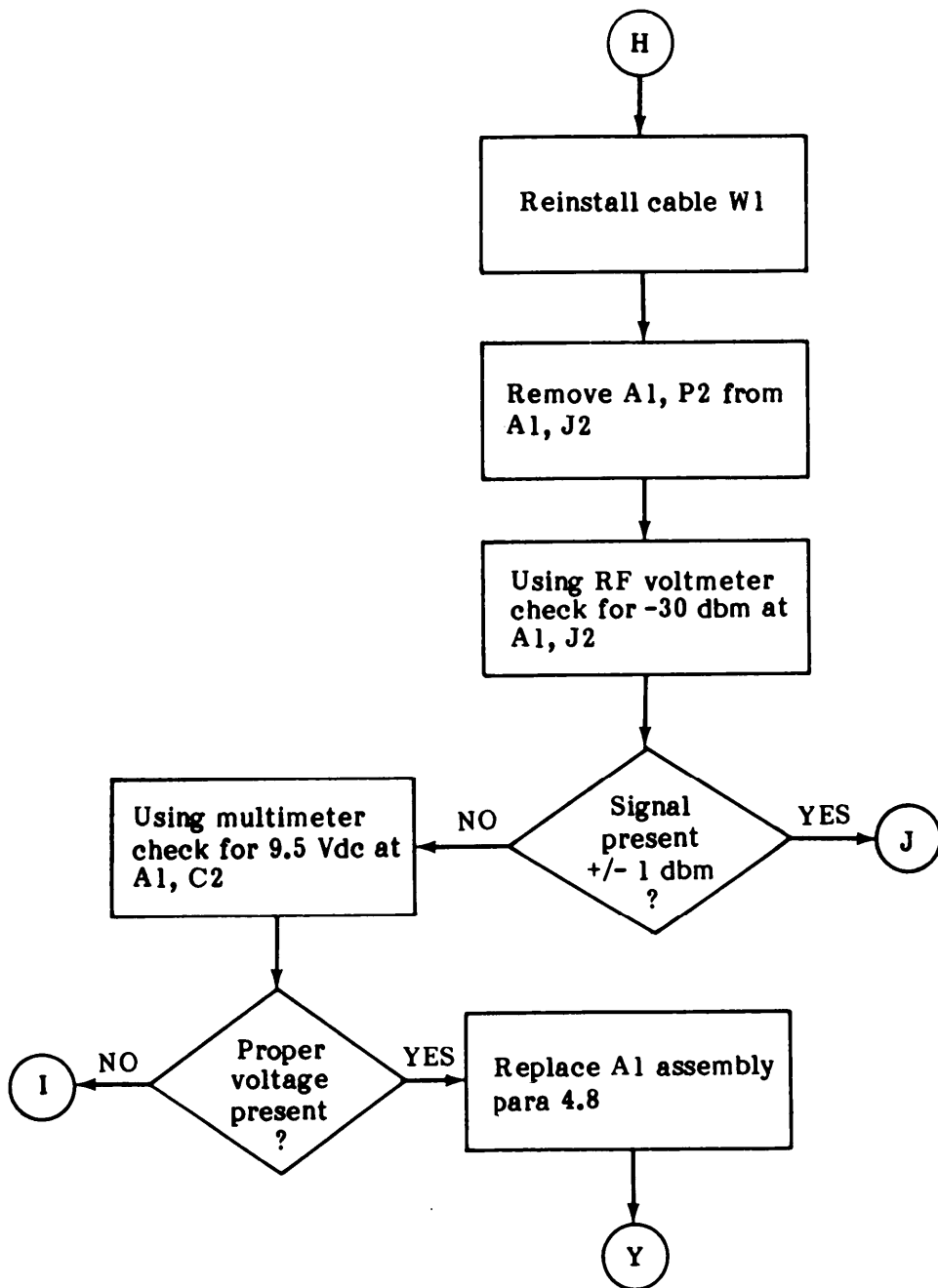


TABLE 4-1







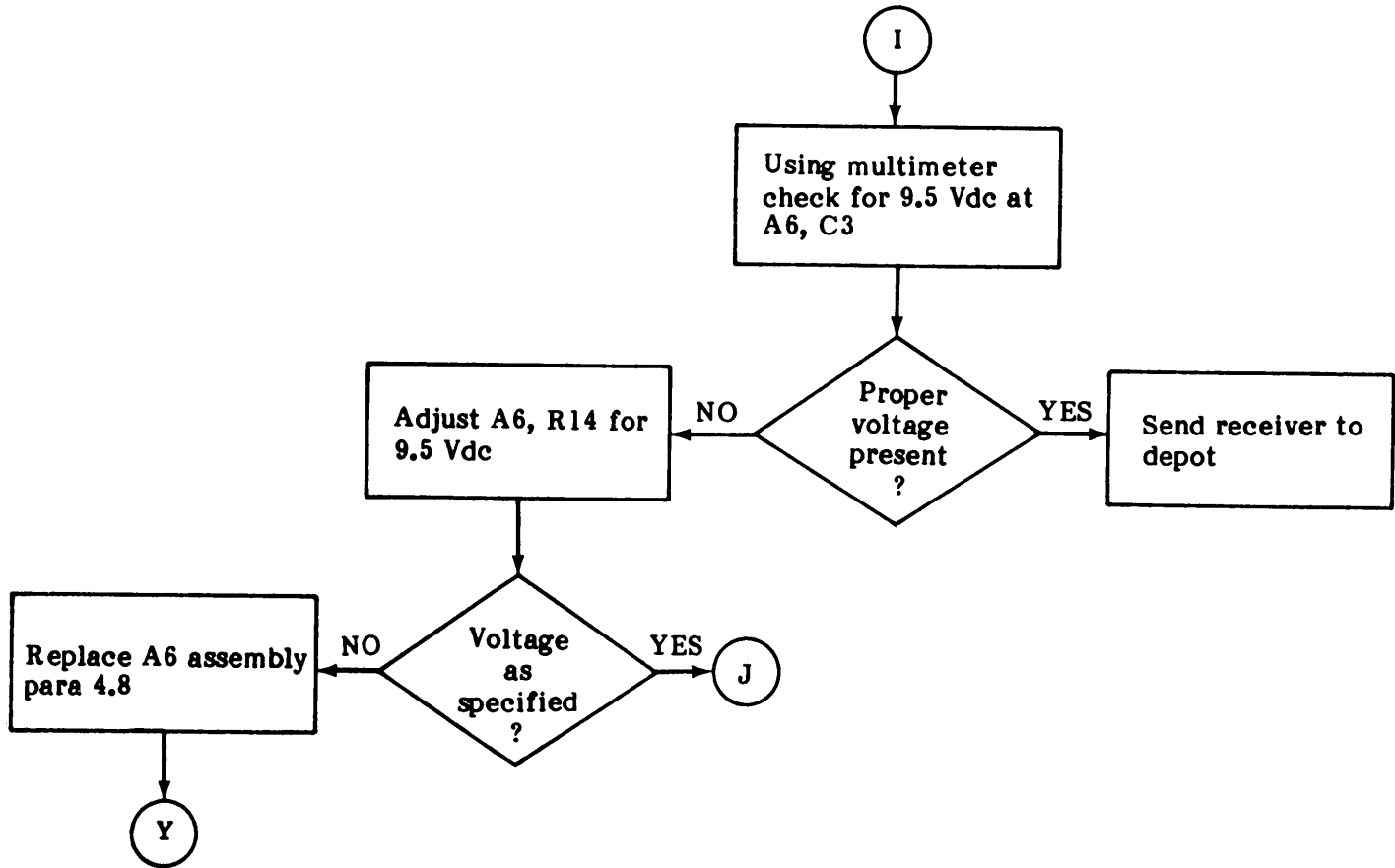
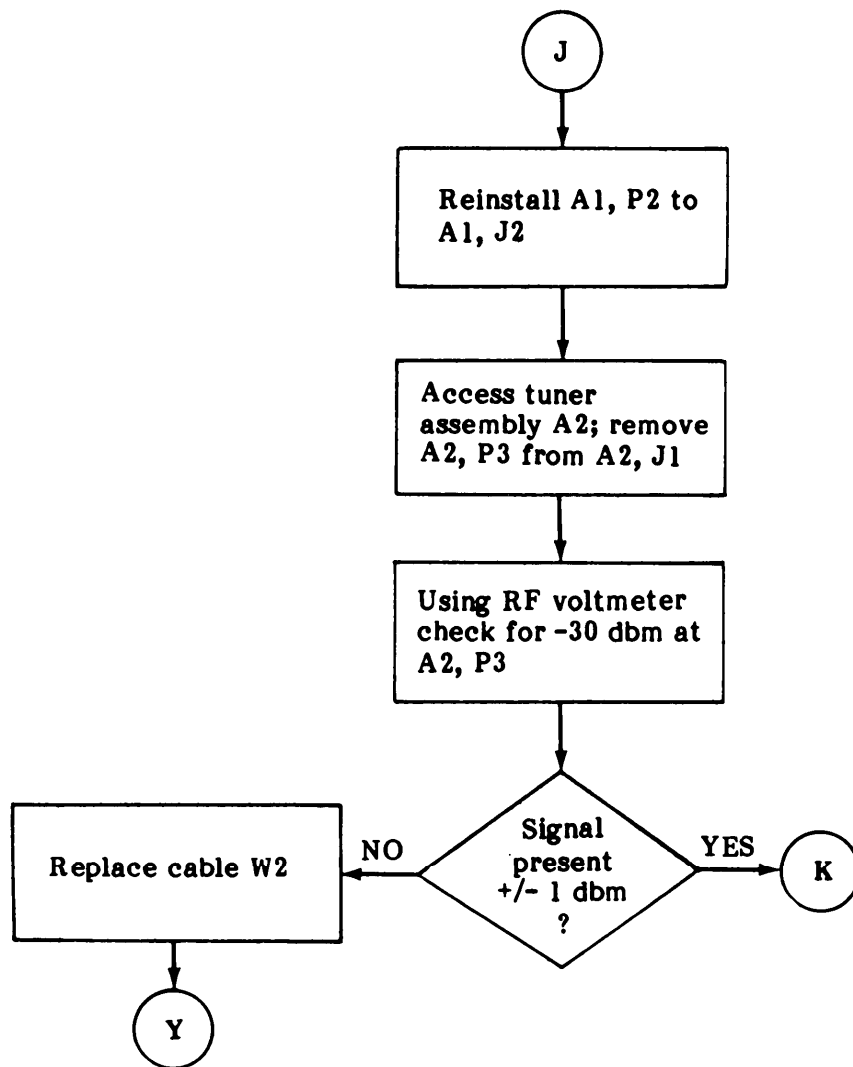
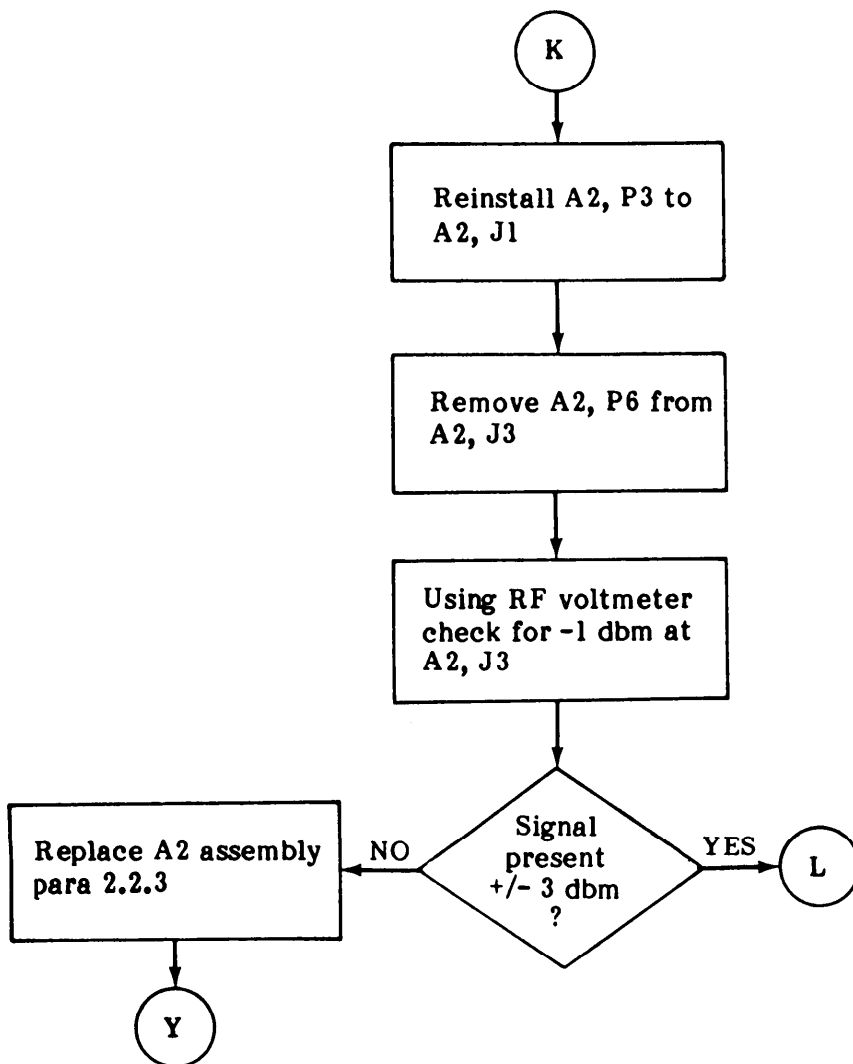
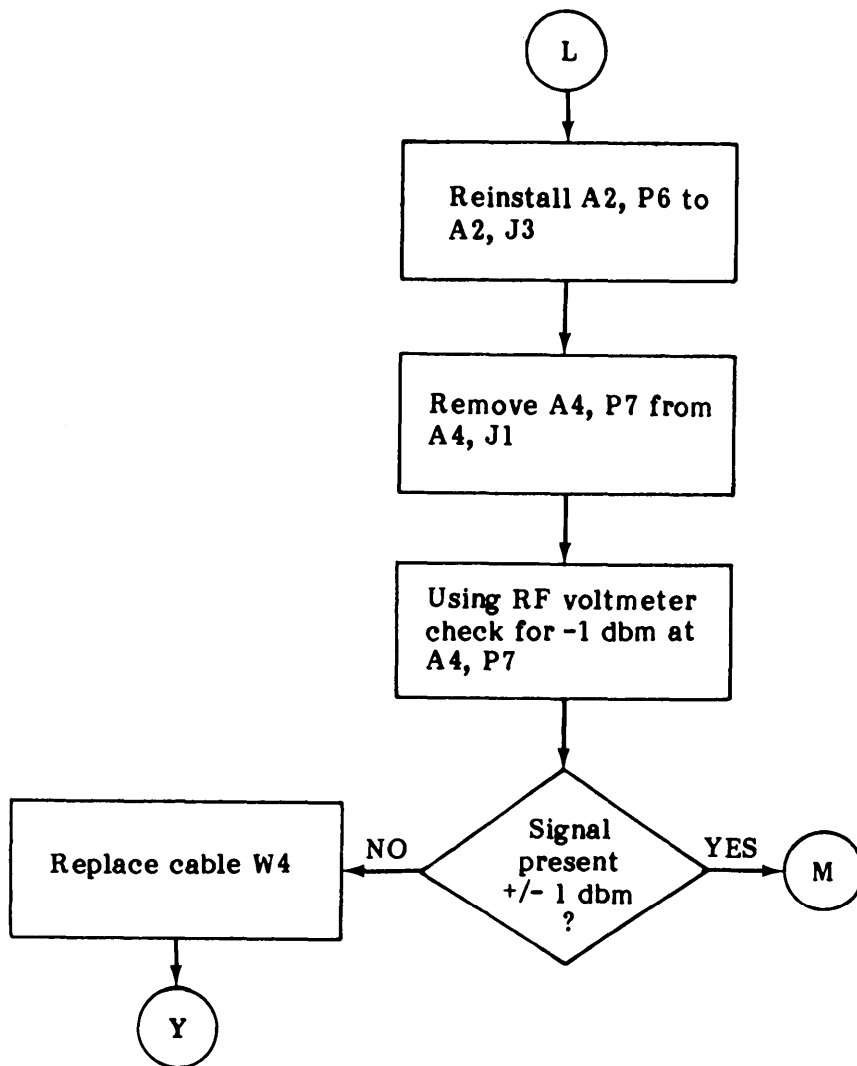
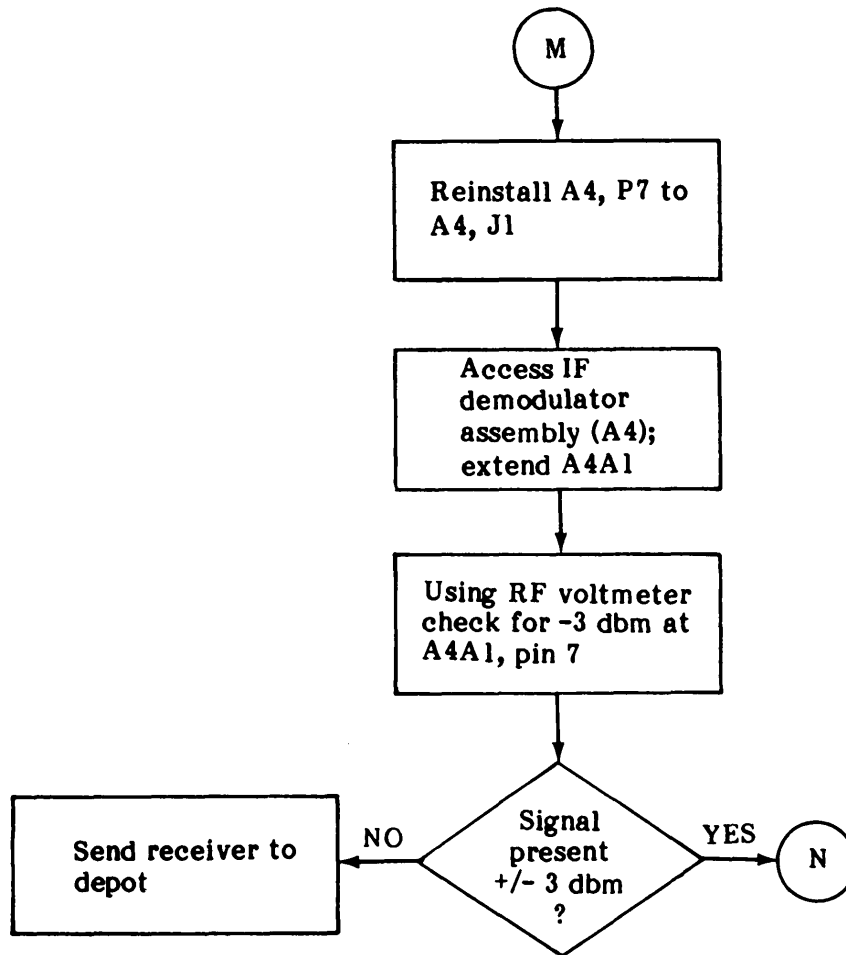


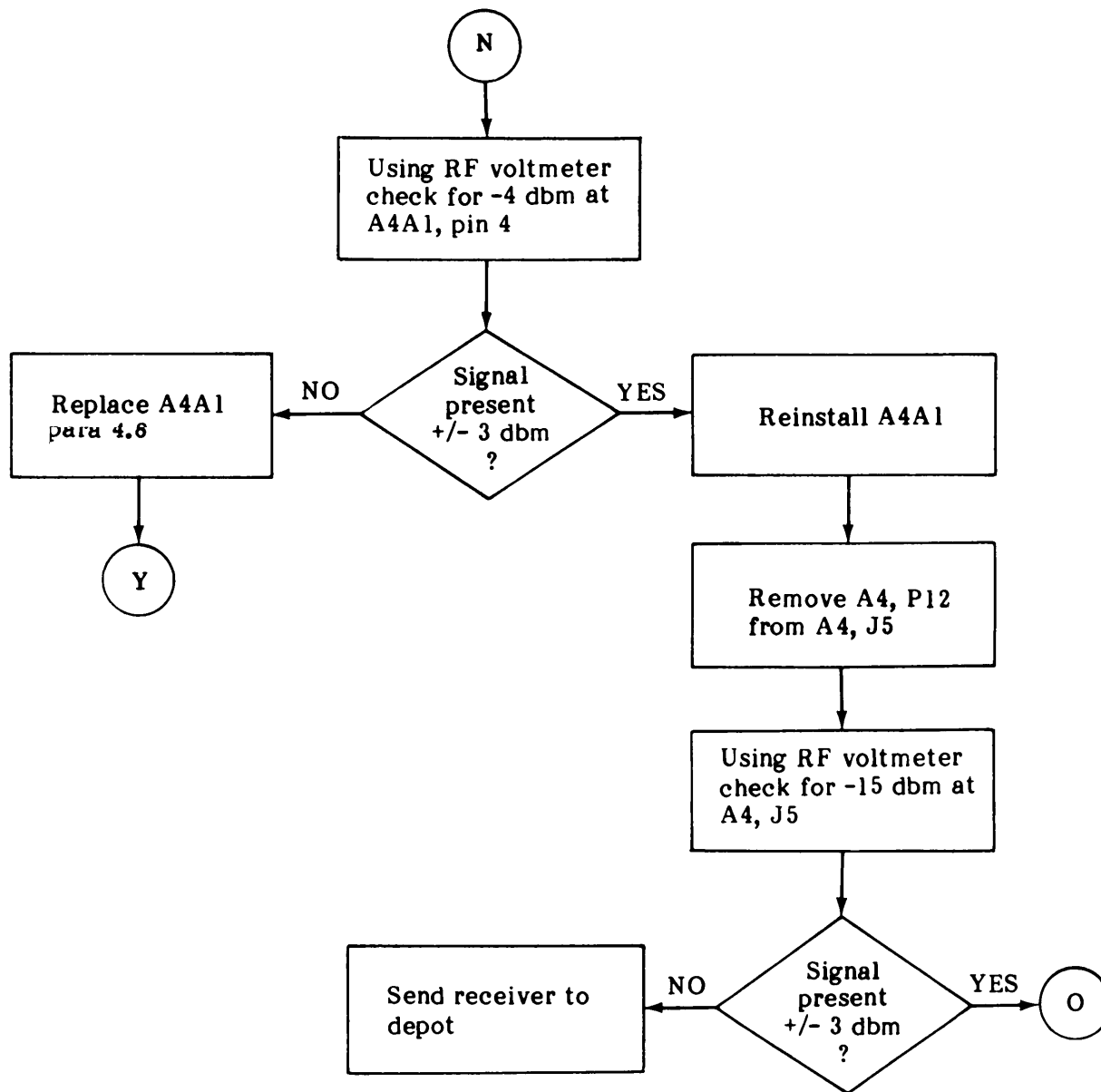
TABLE 4-1

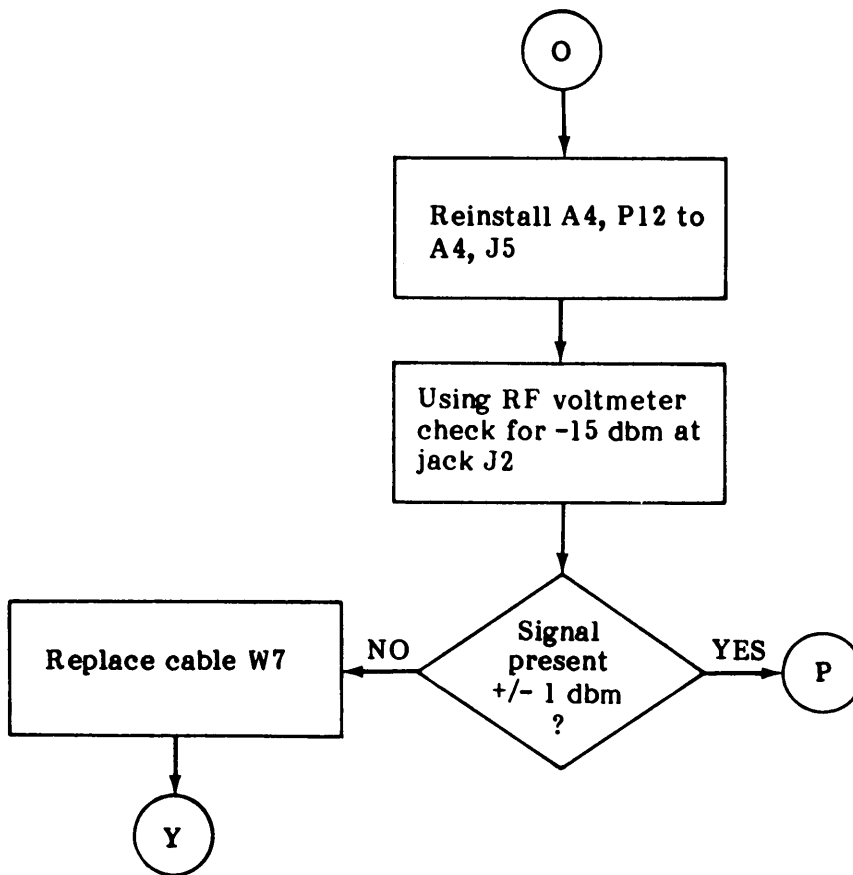


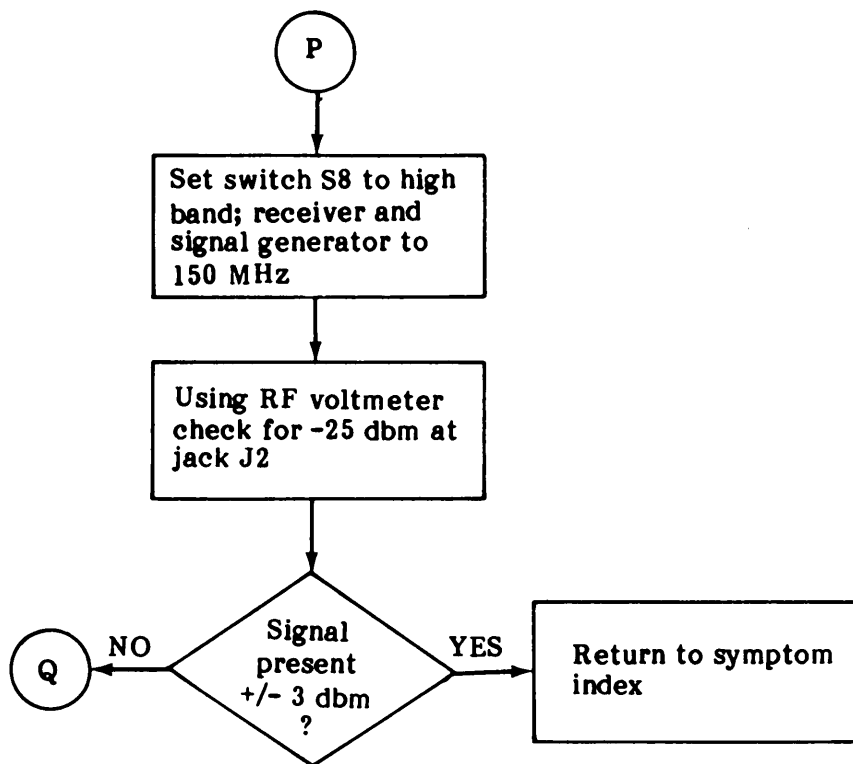


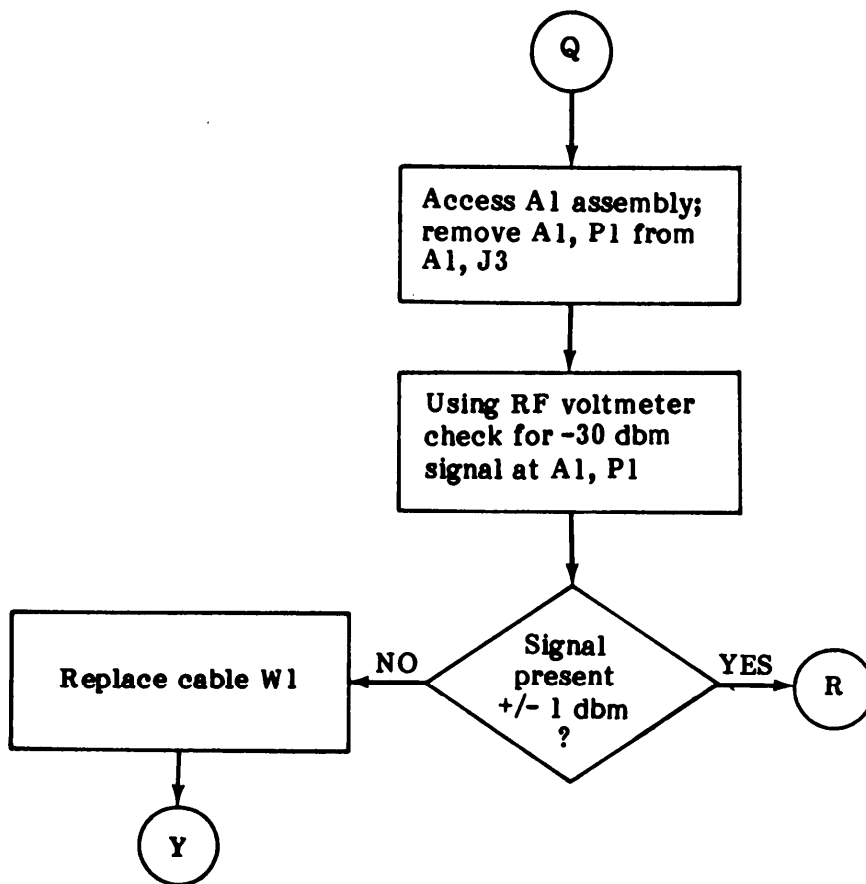


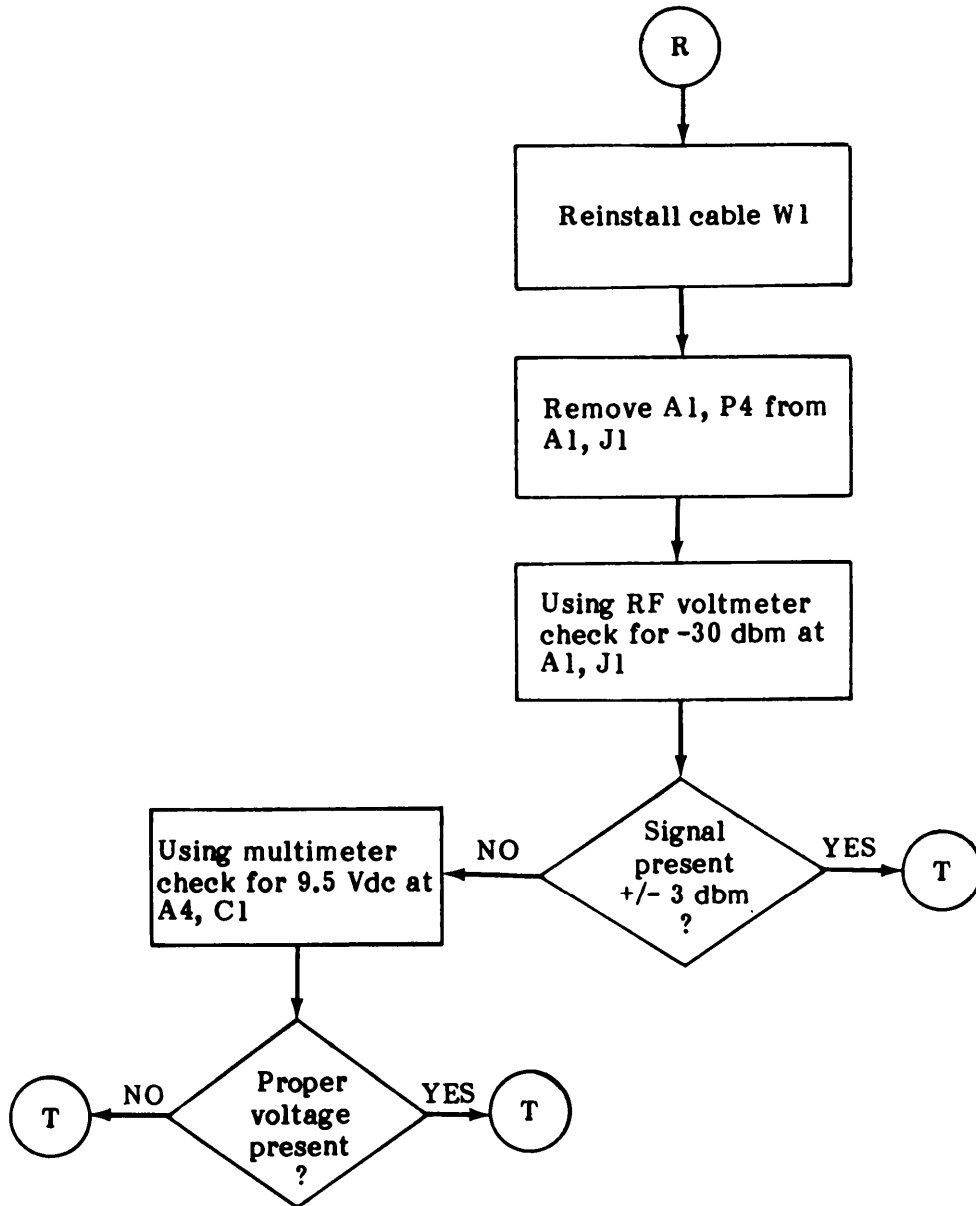


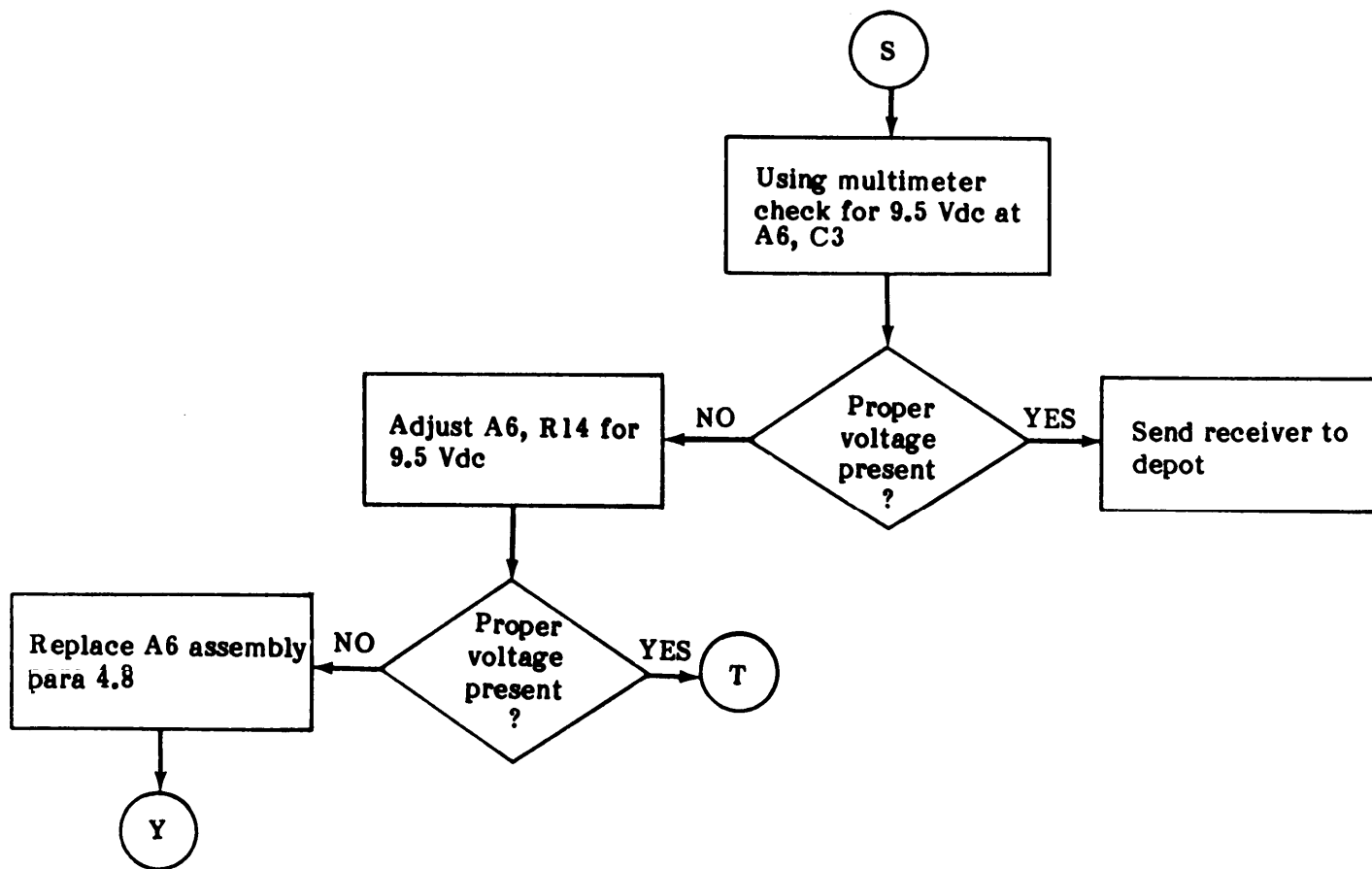


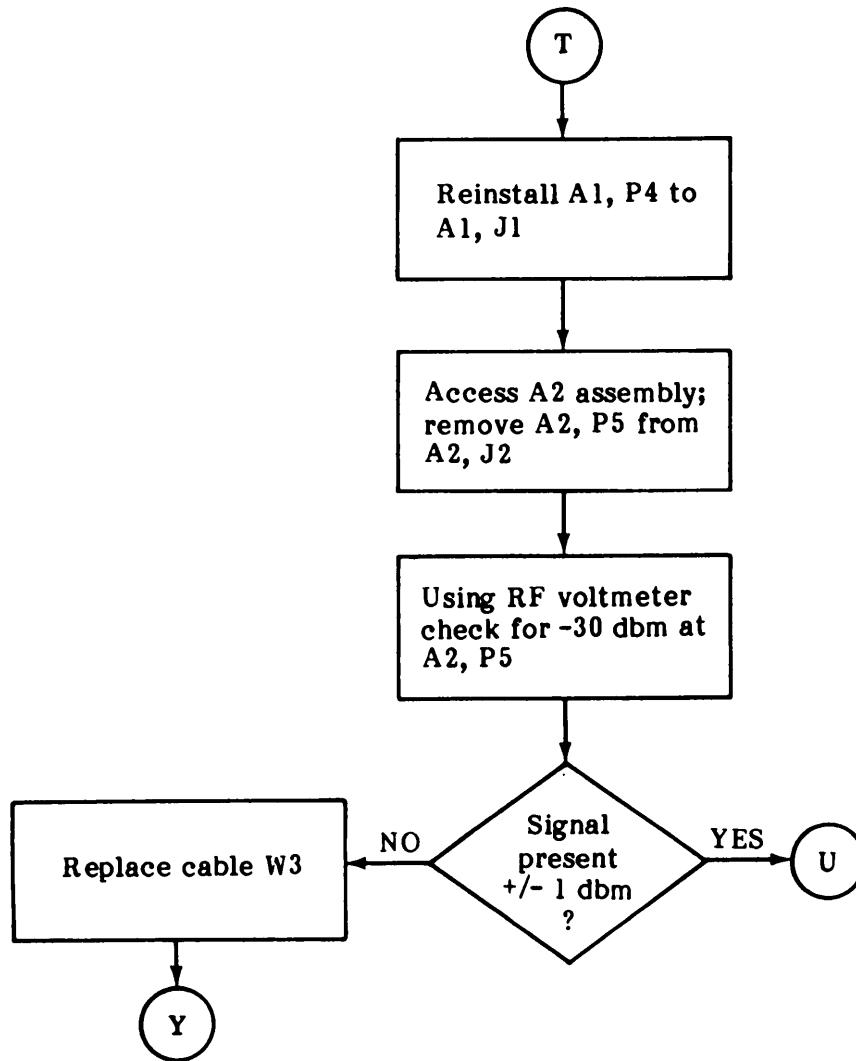












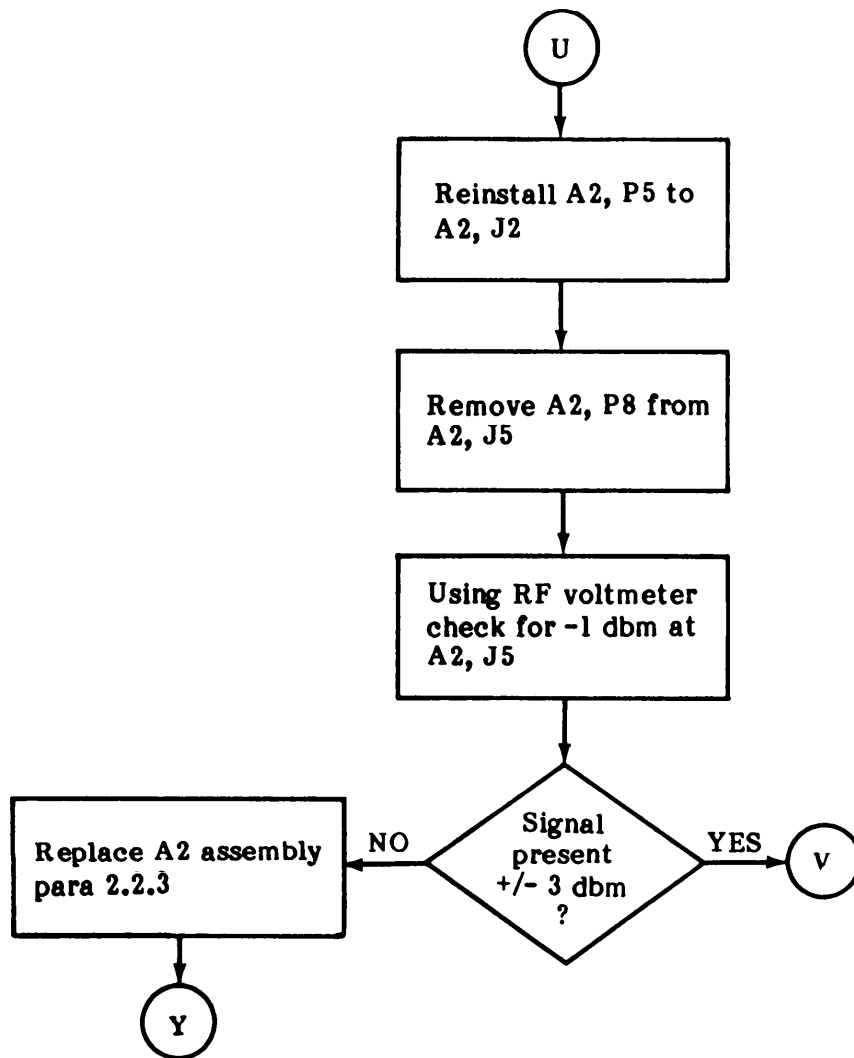
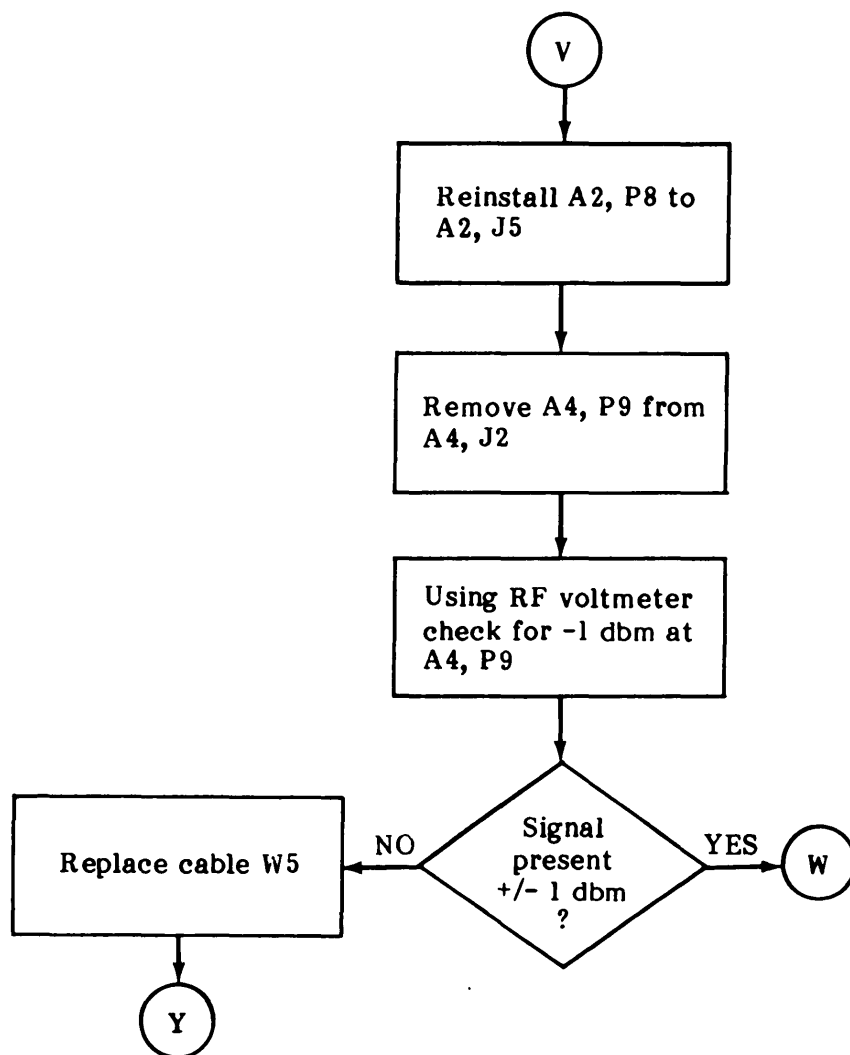
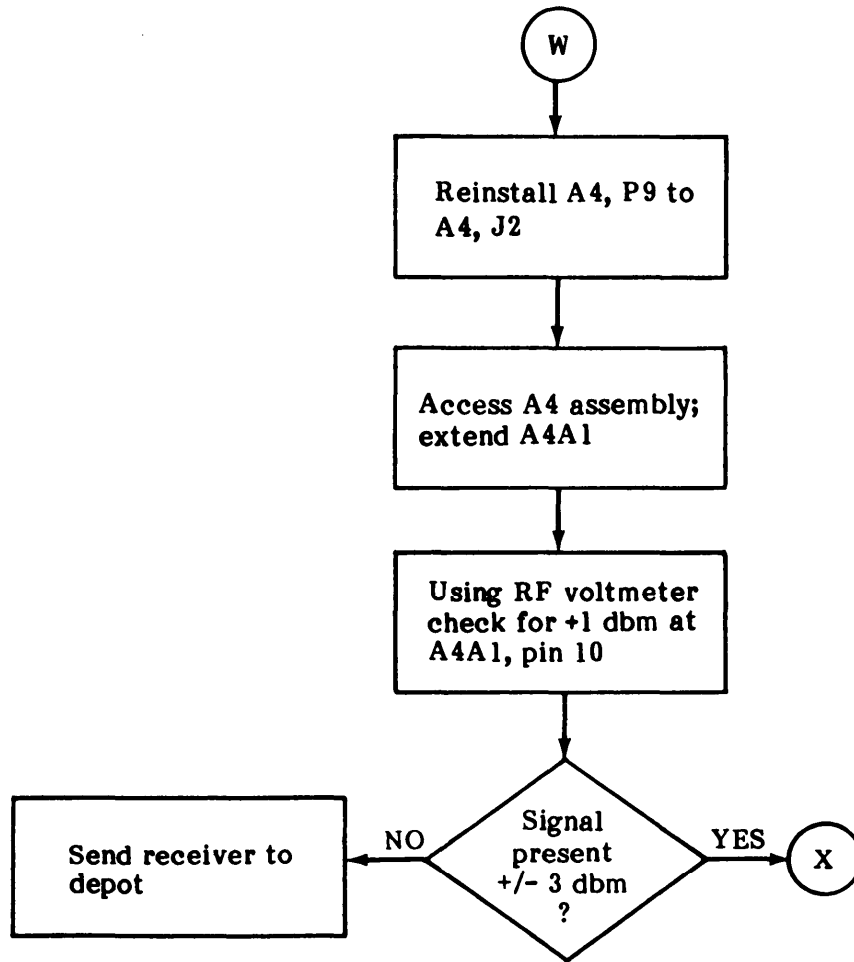
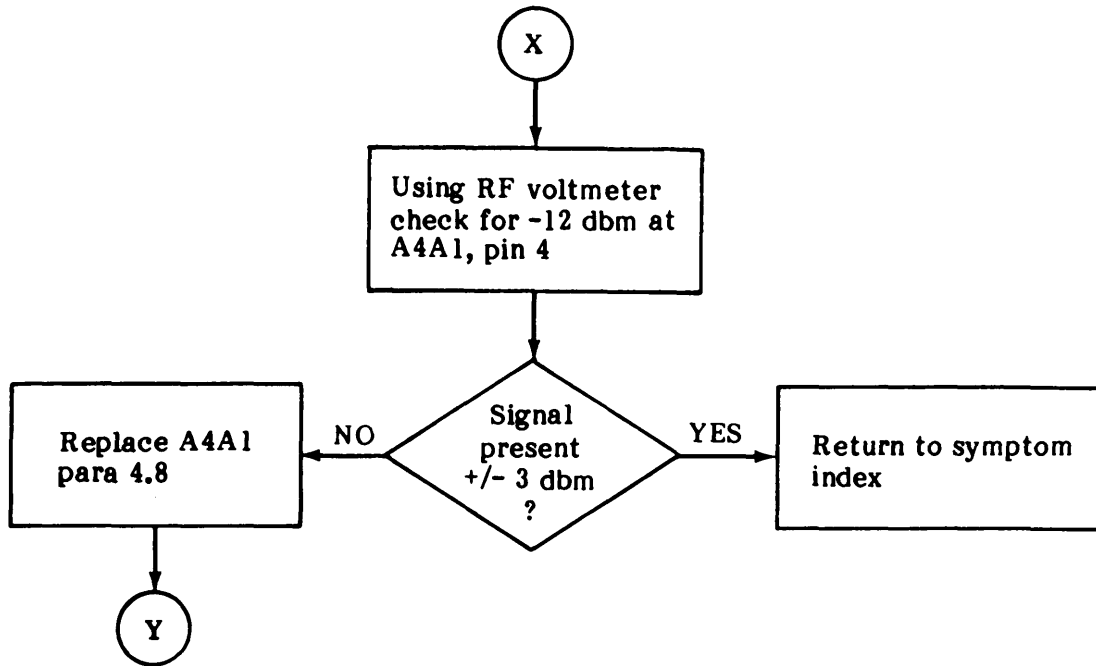
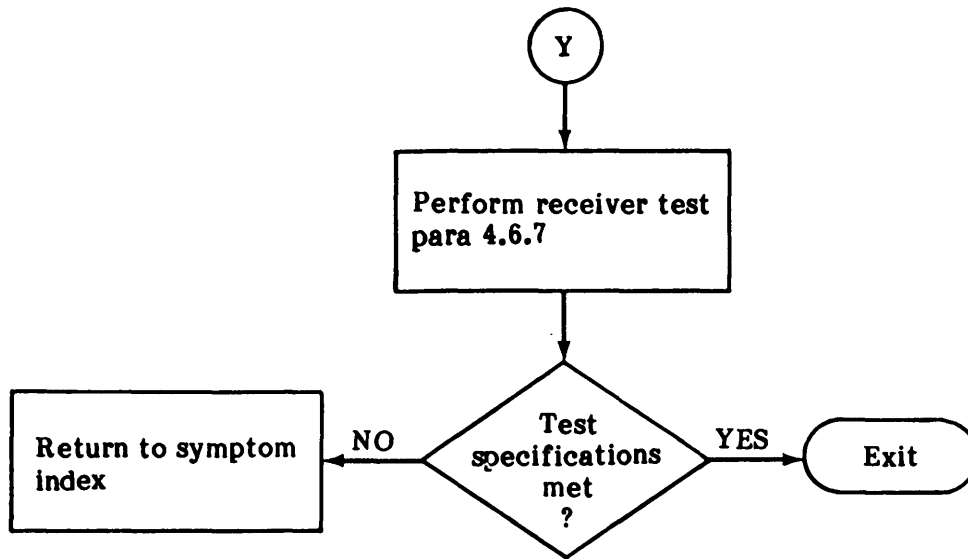


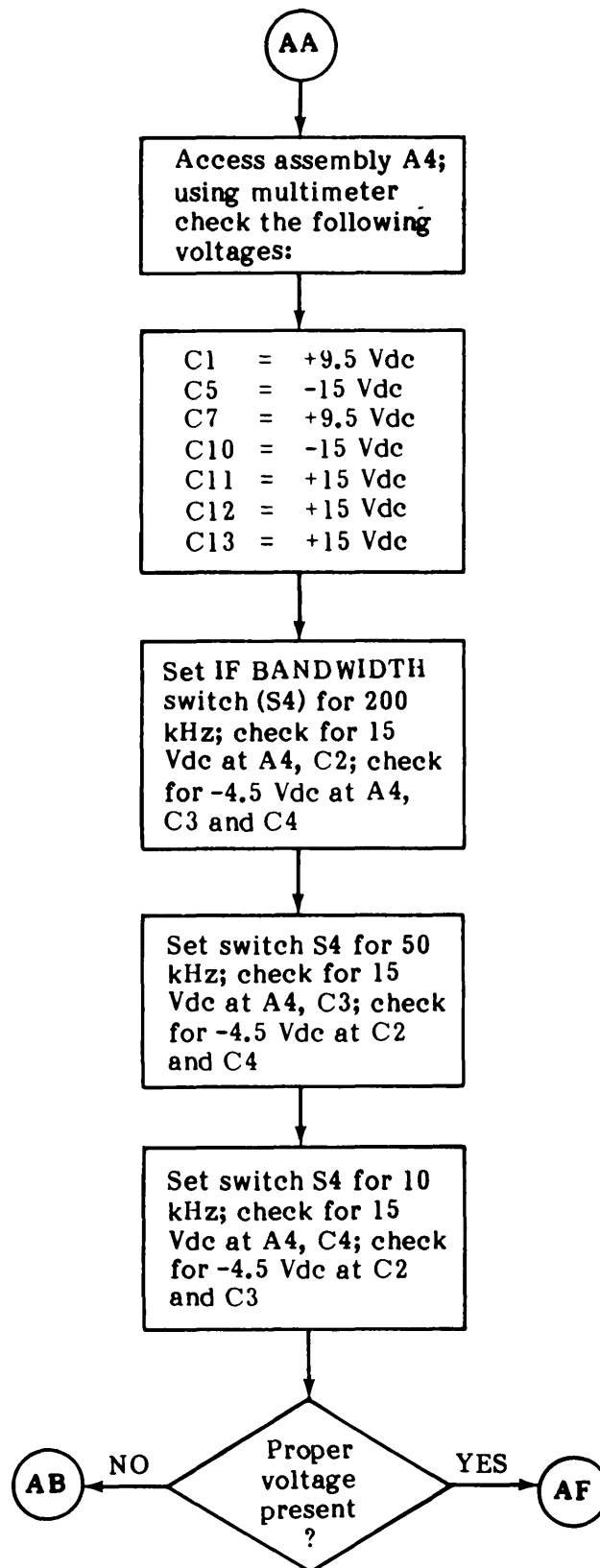
TABLE 4-1

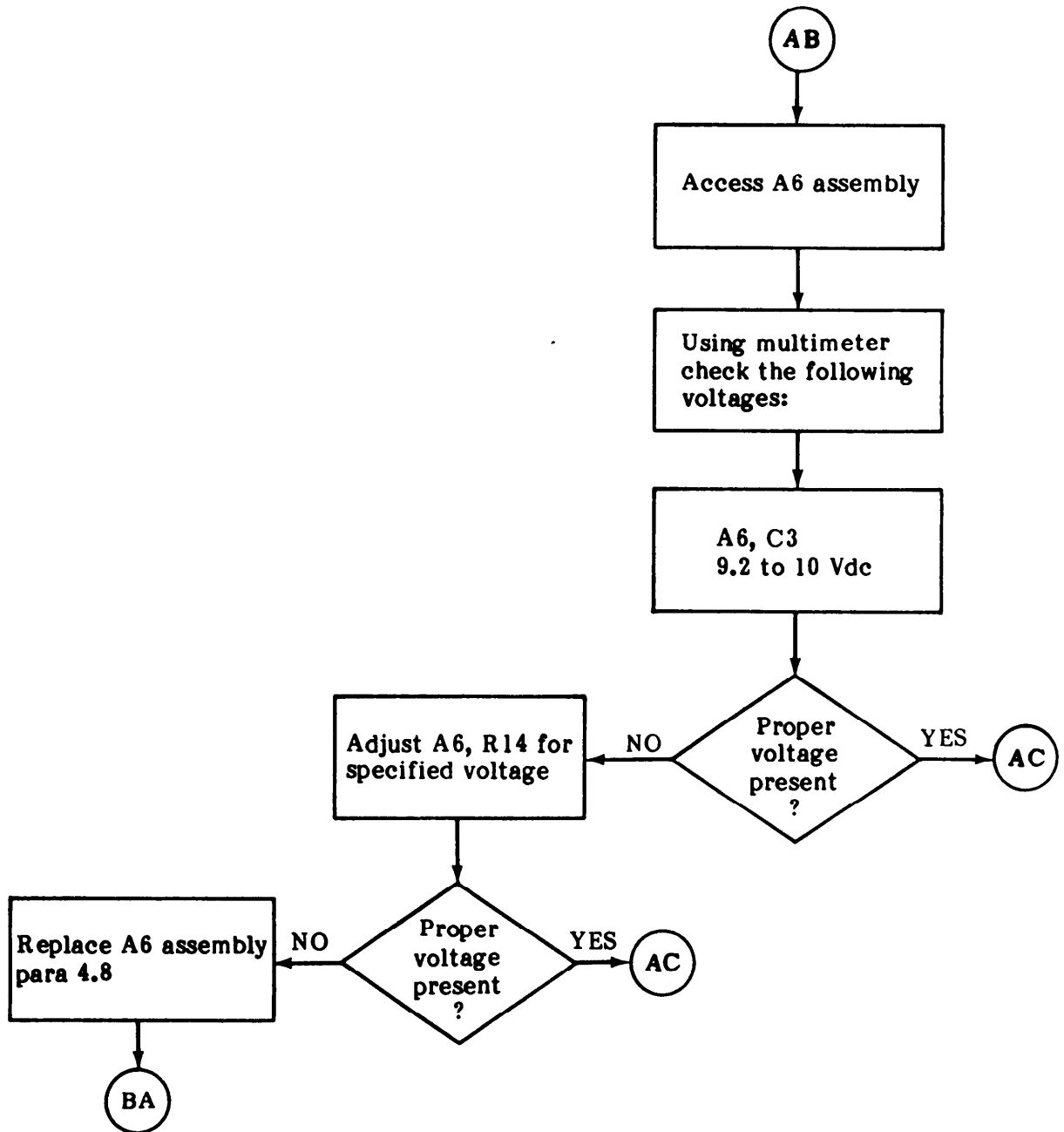


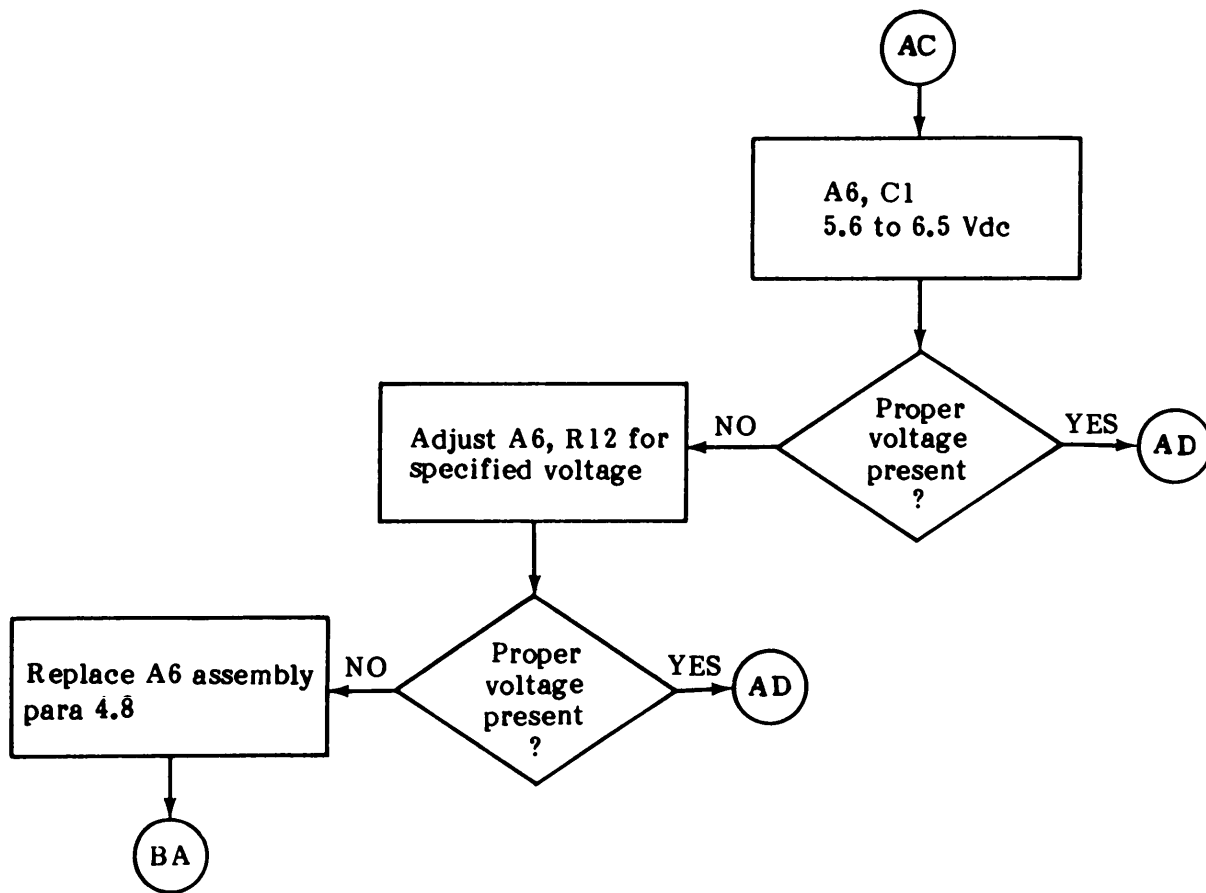


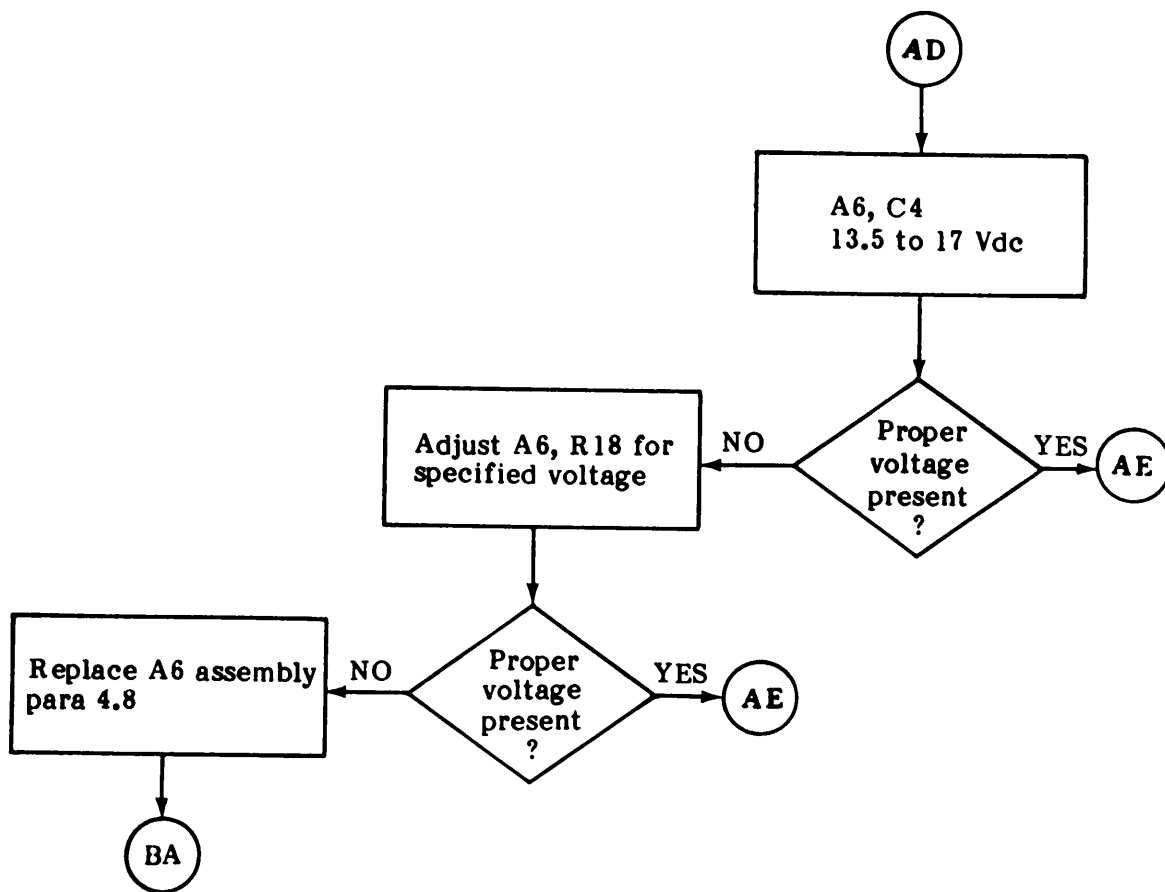


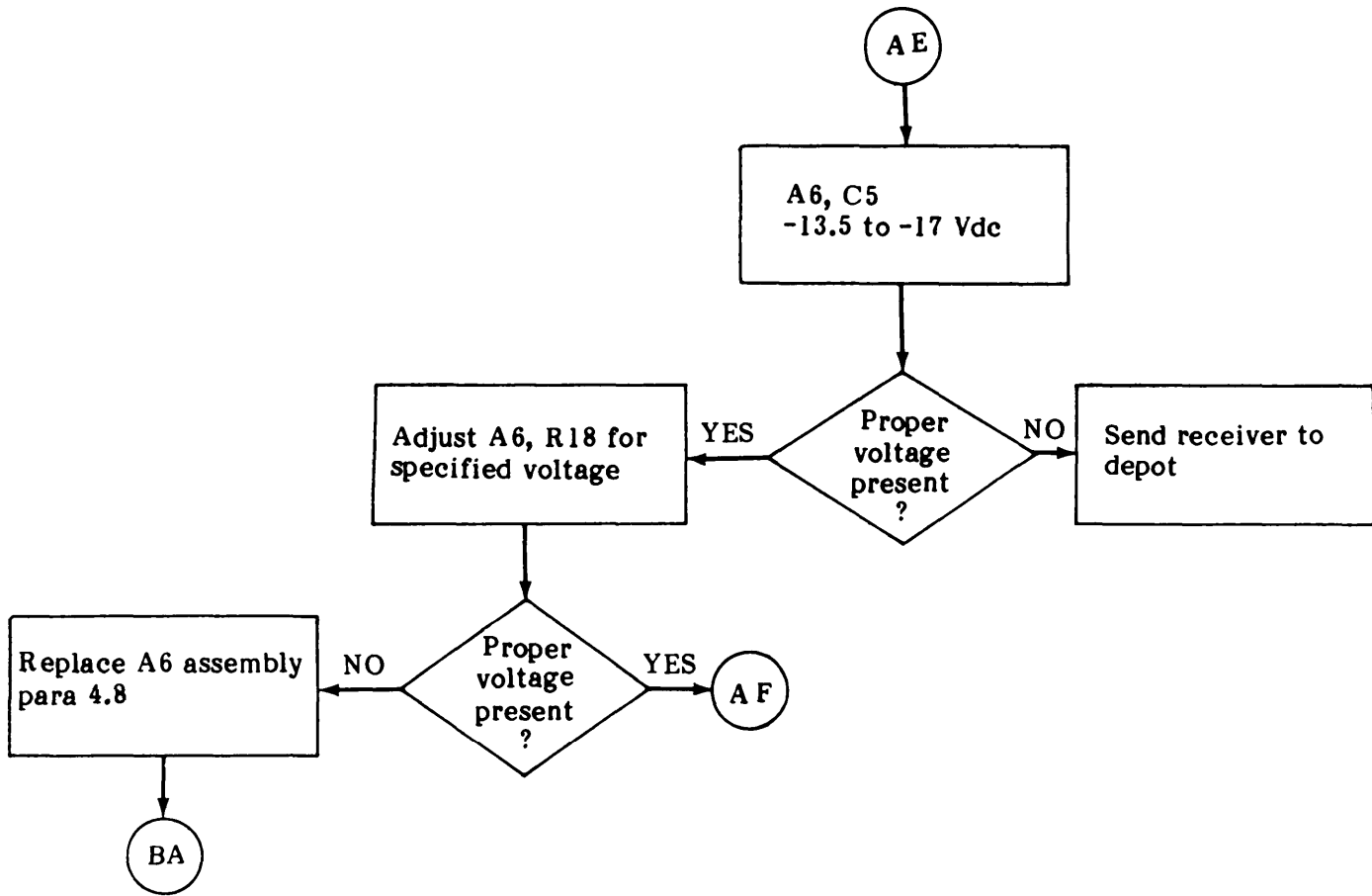












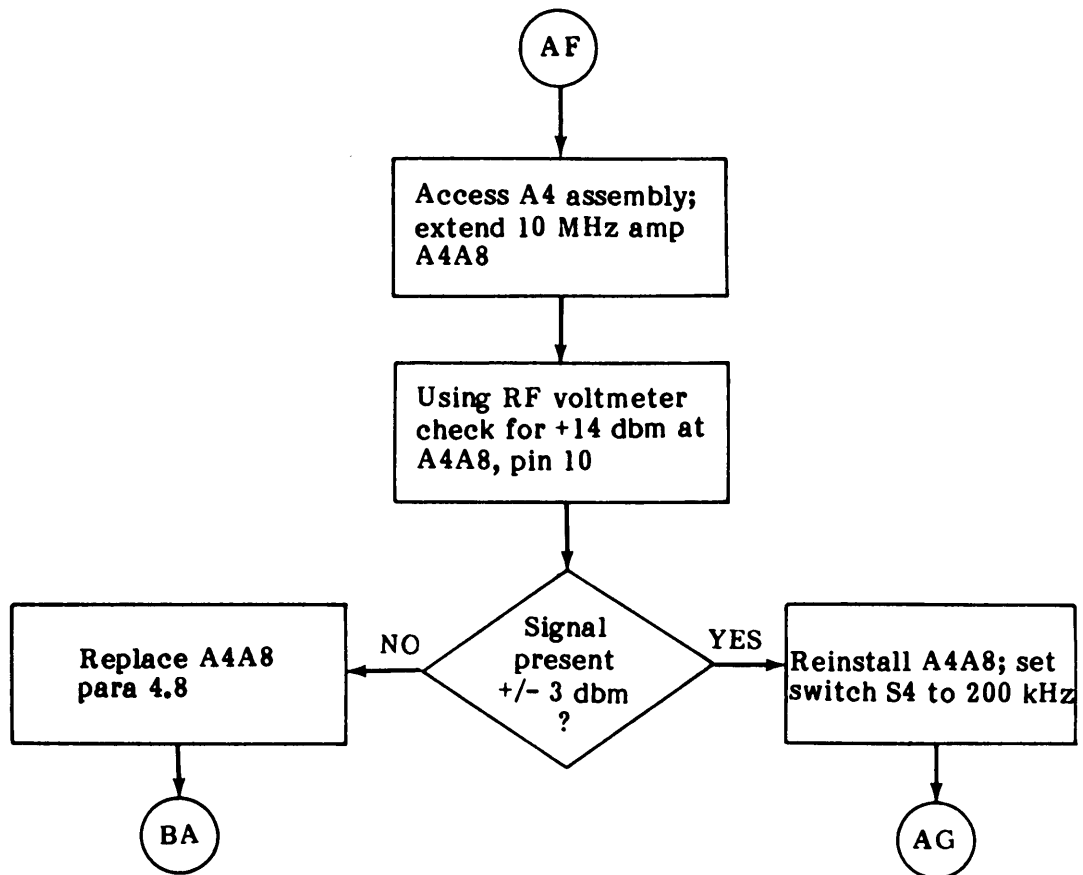
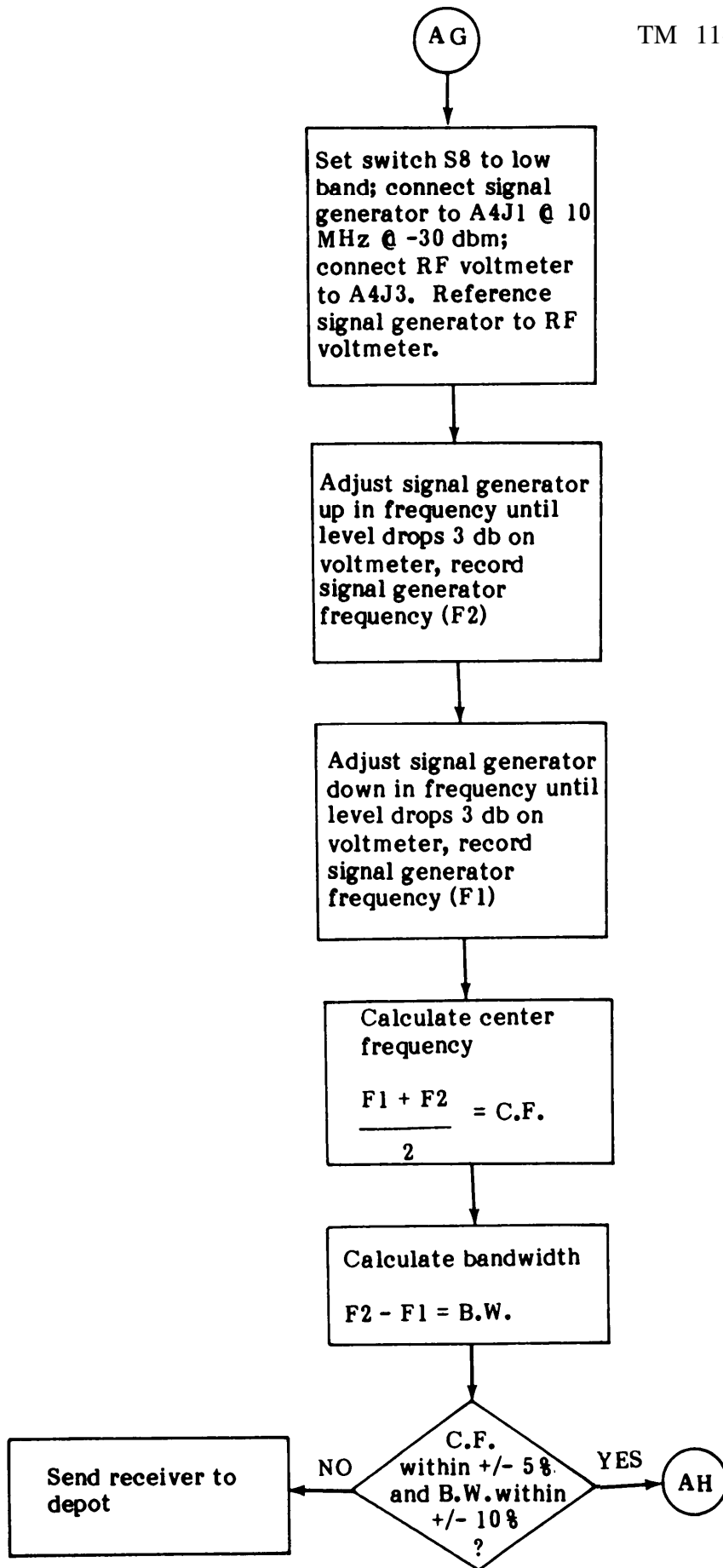
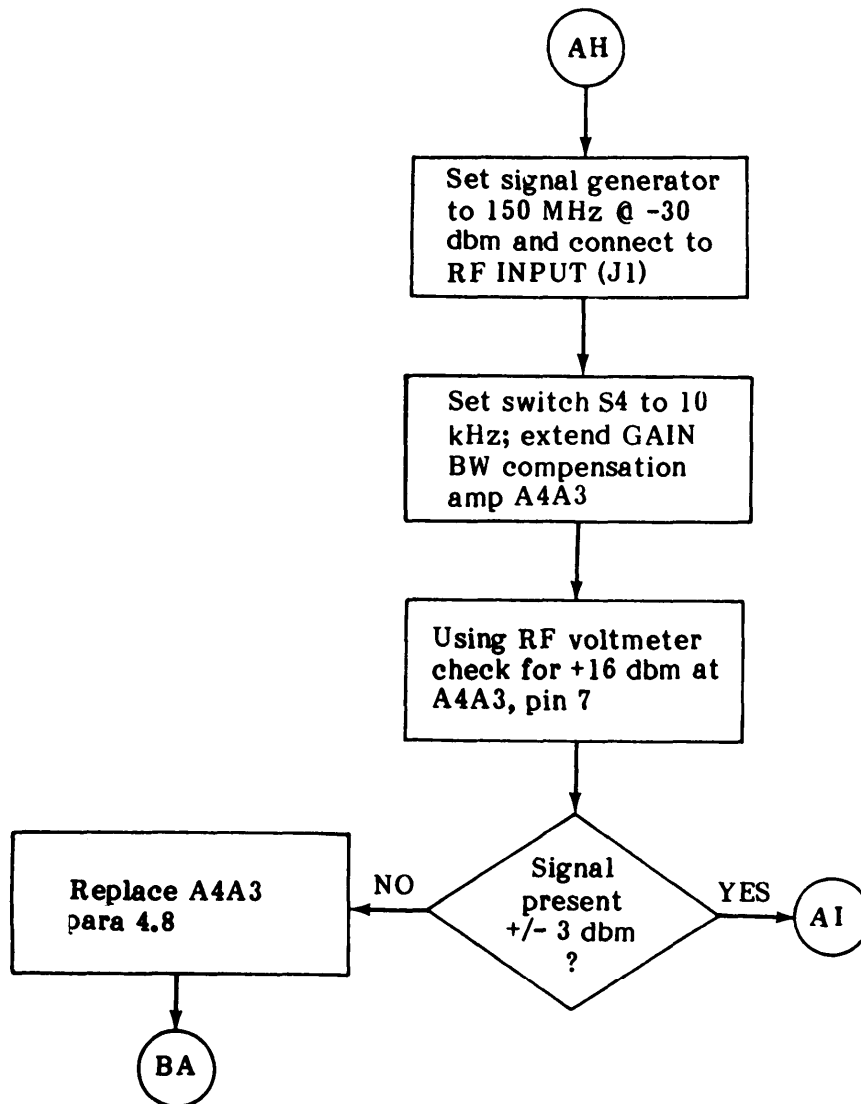
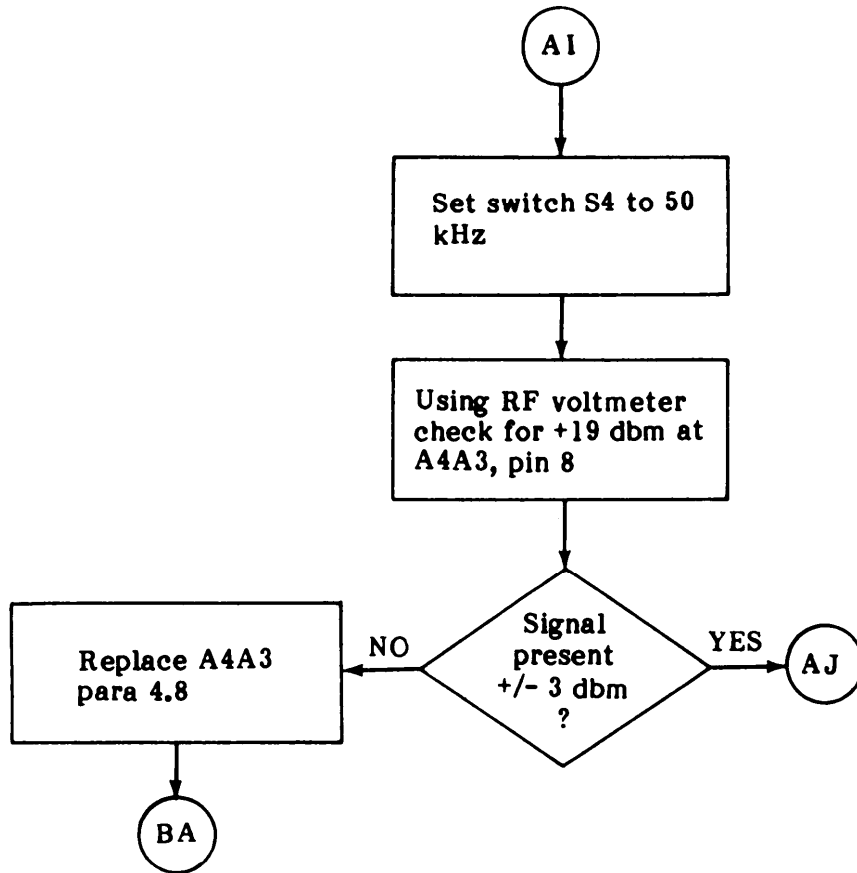
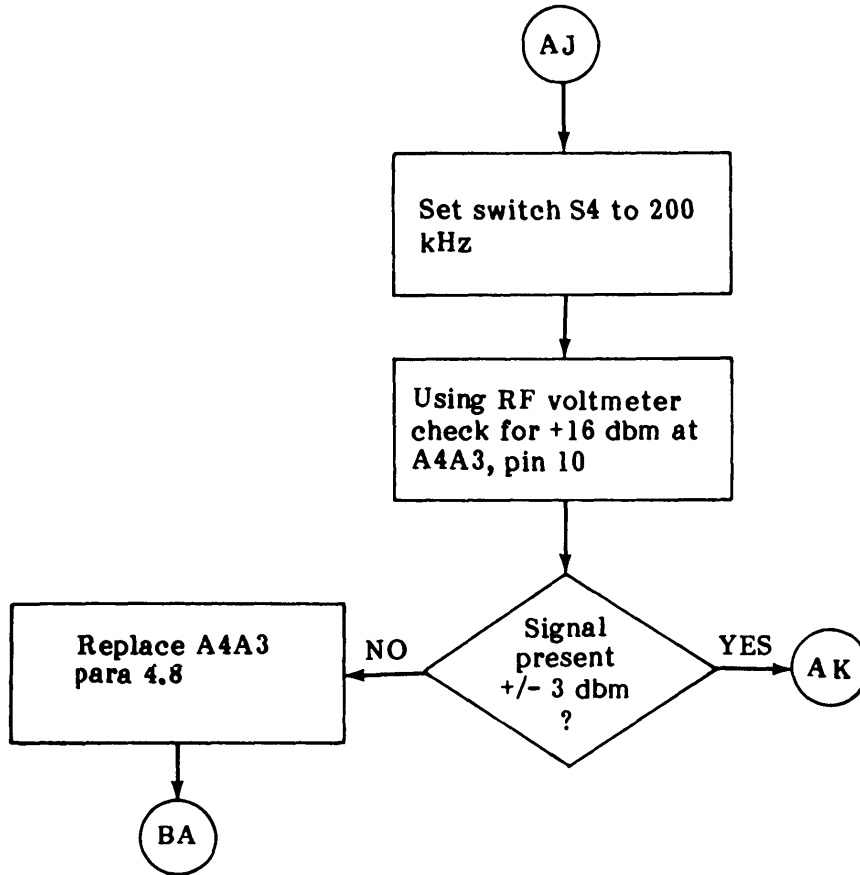


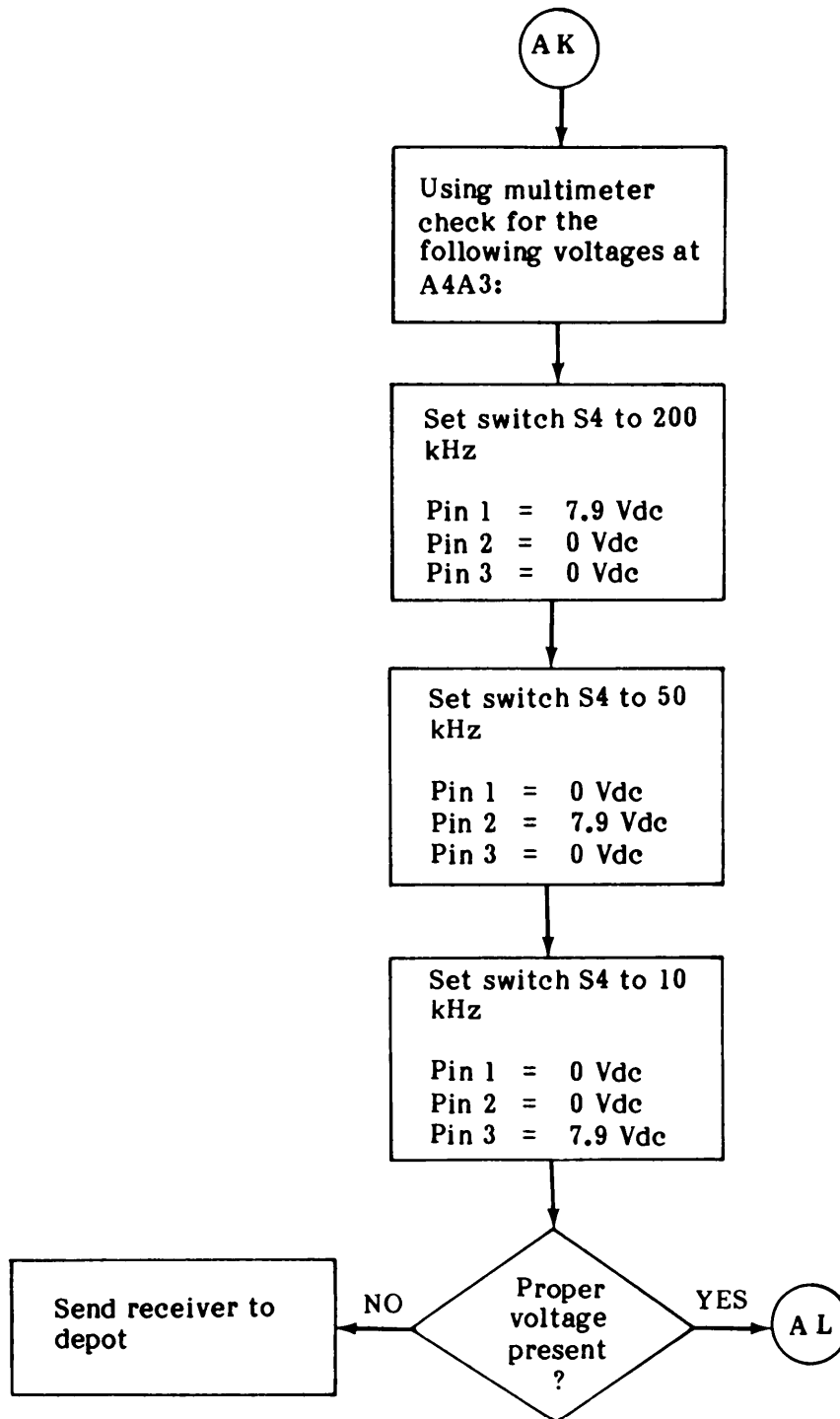
TABLE 4-1

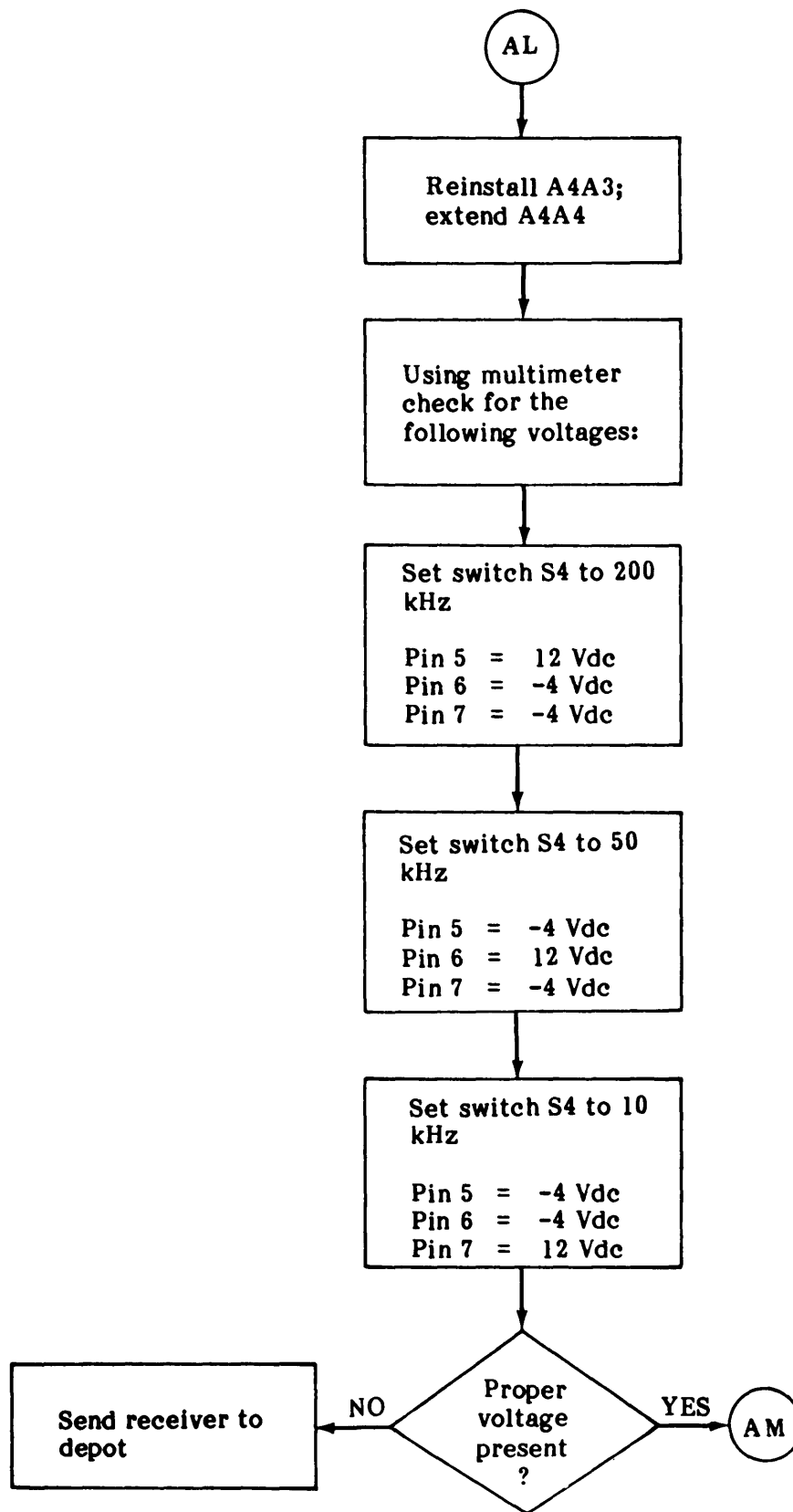


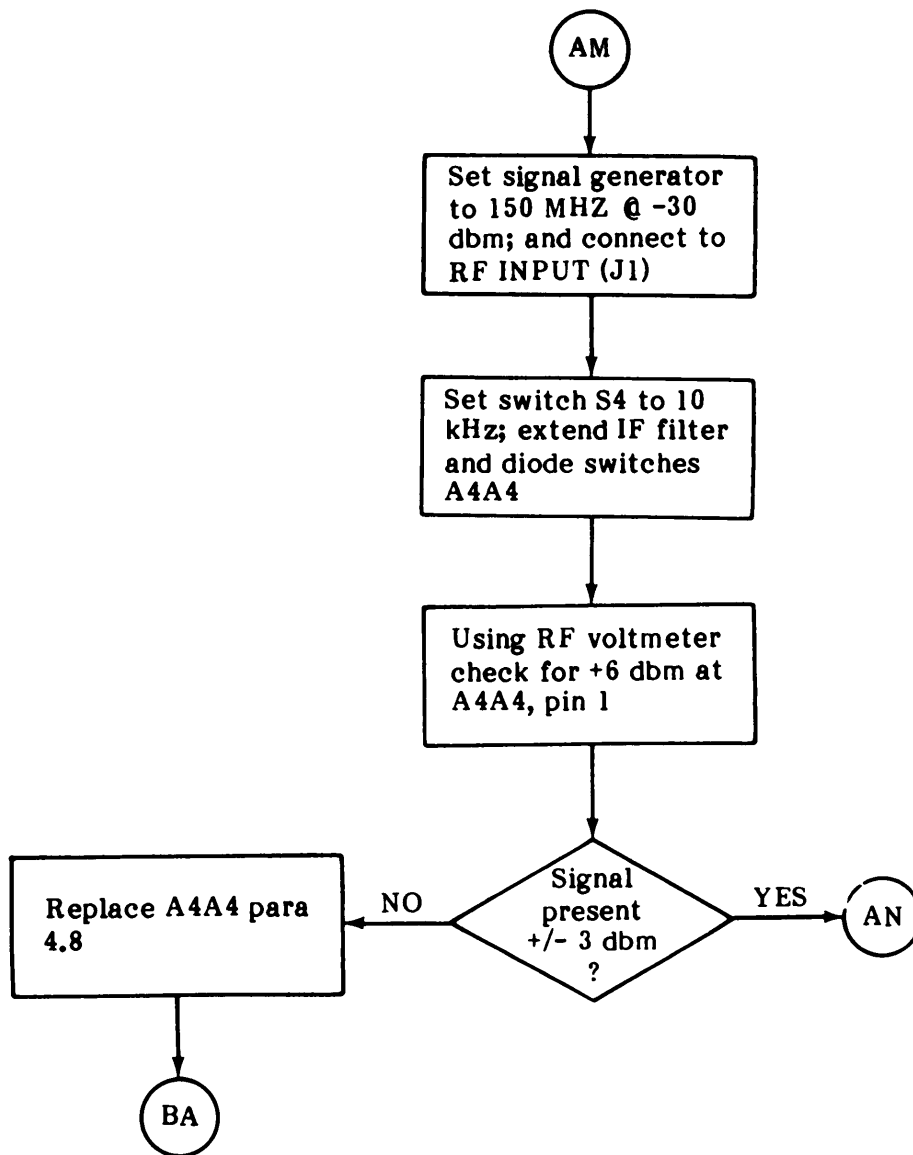


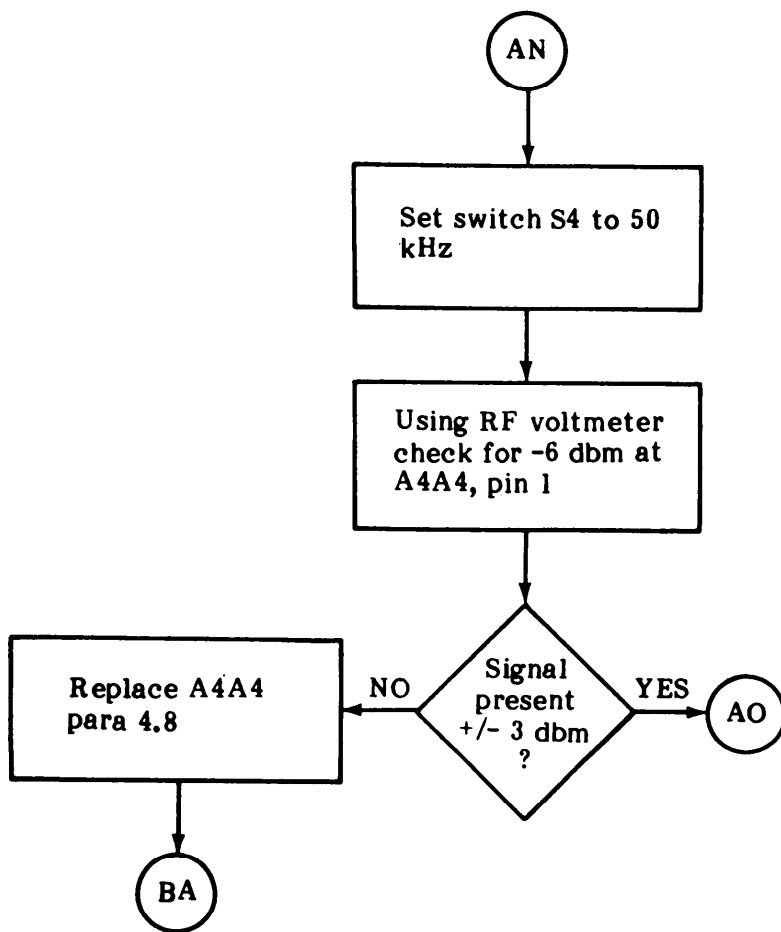


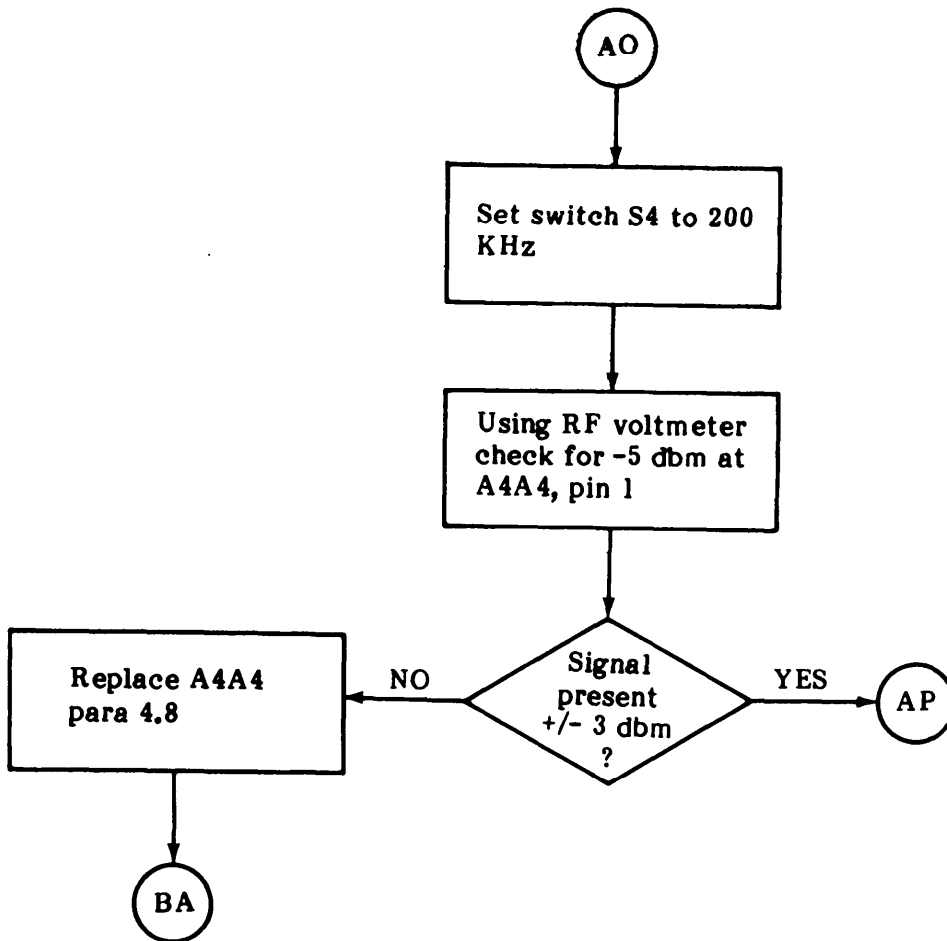


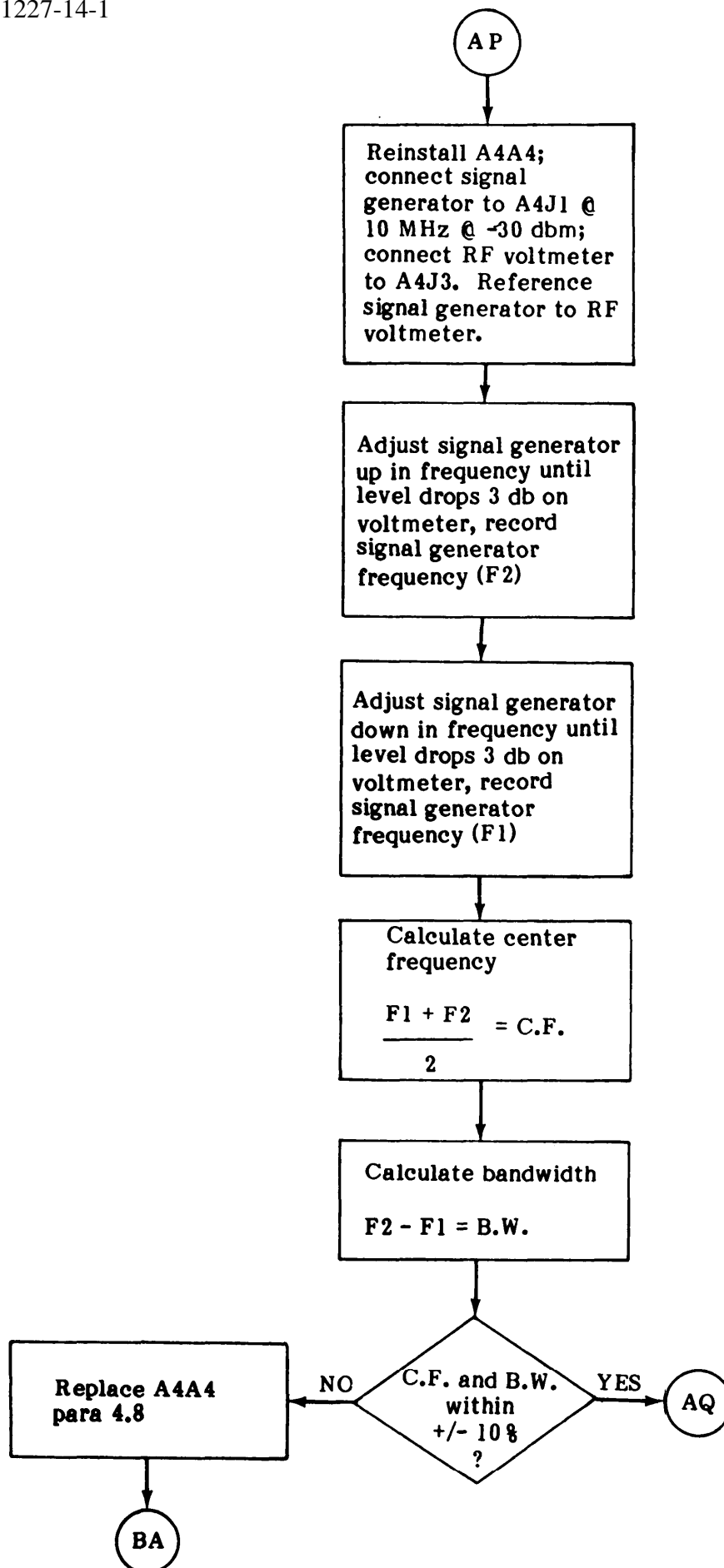


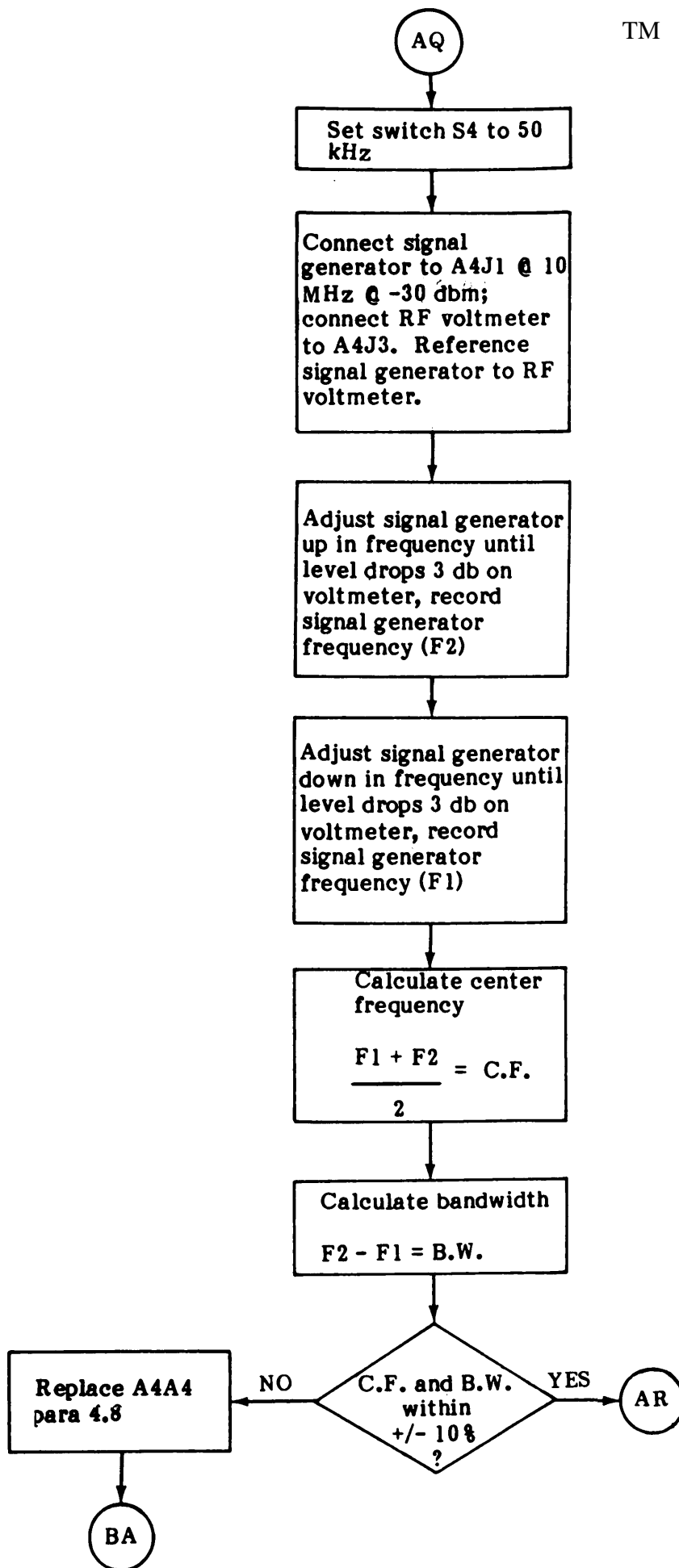












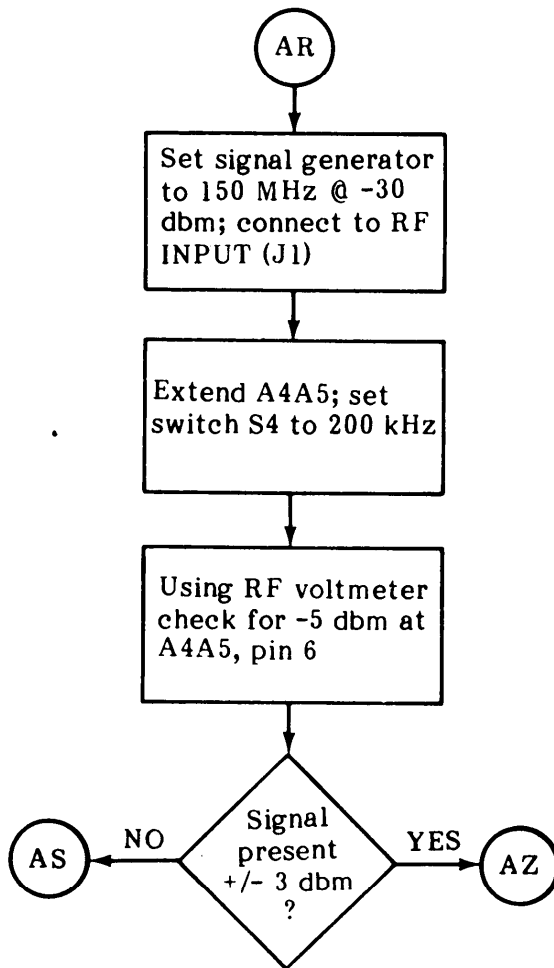
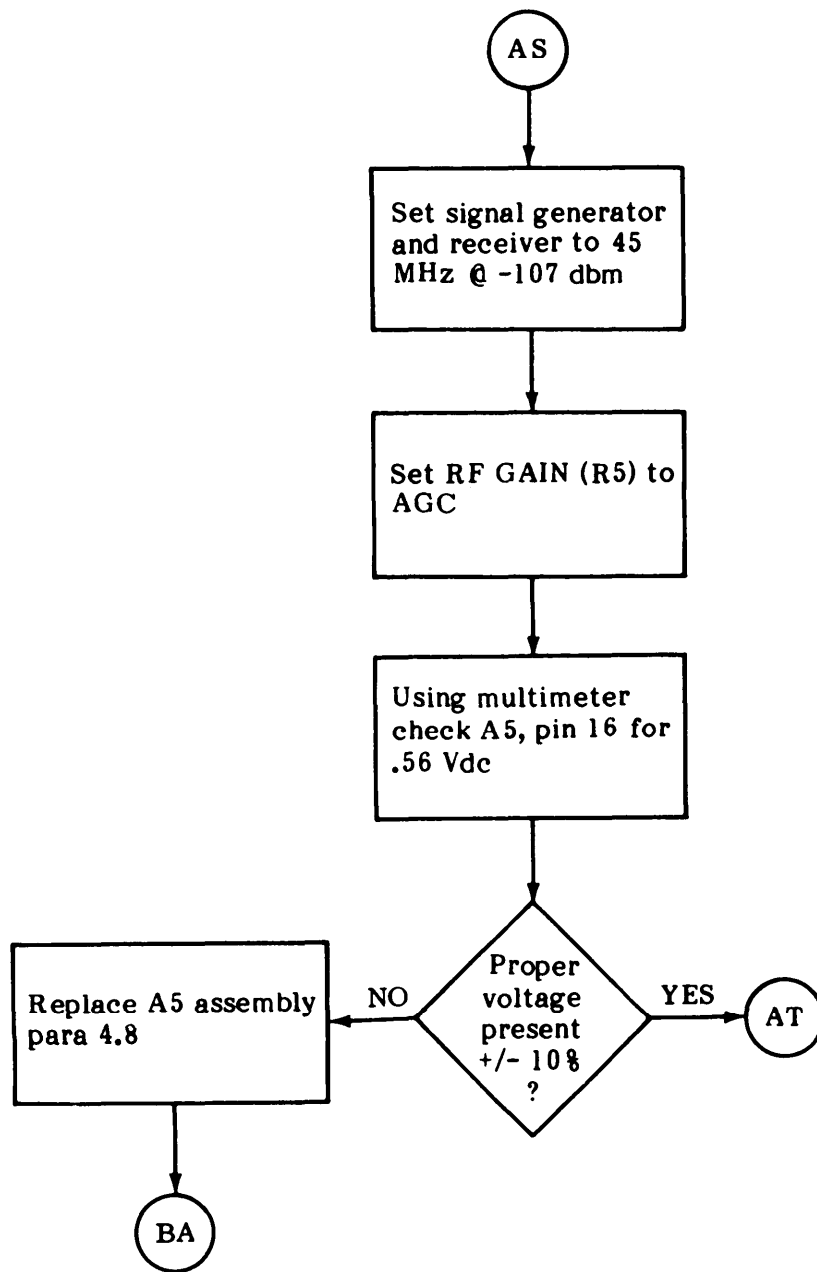
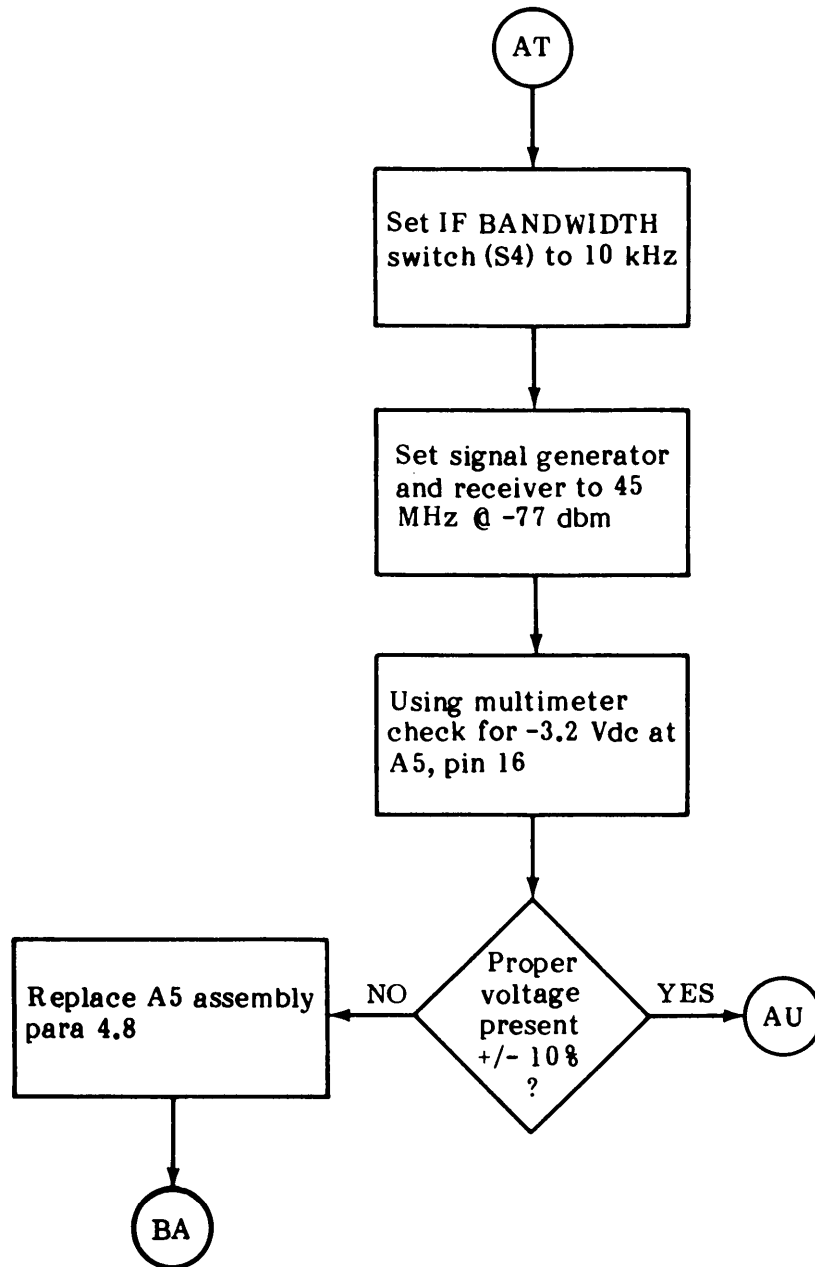
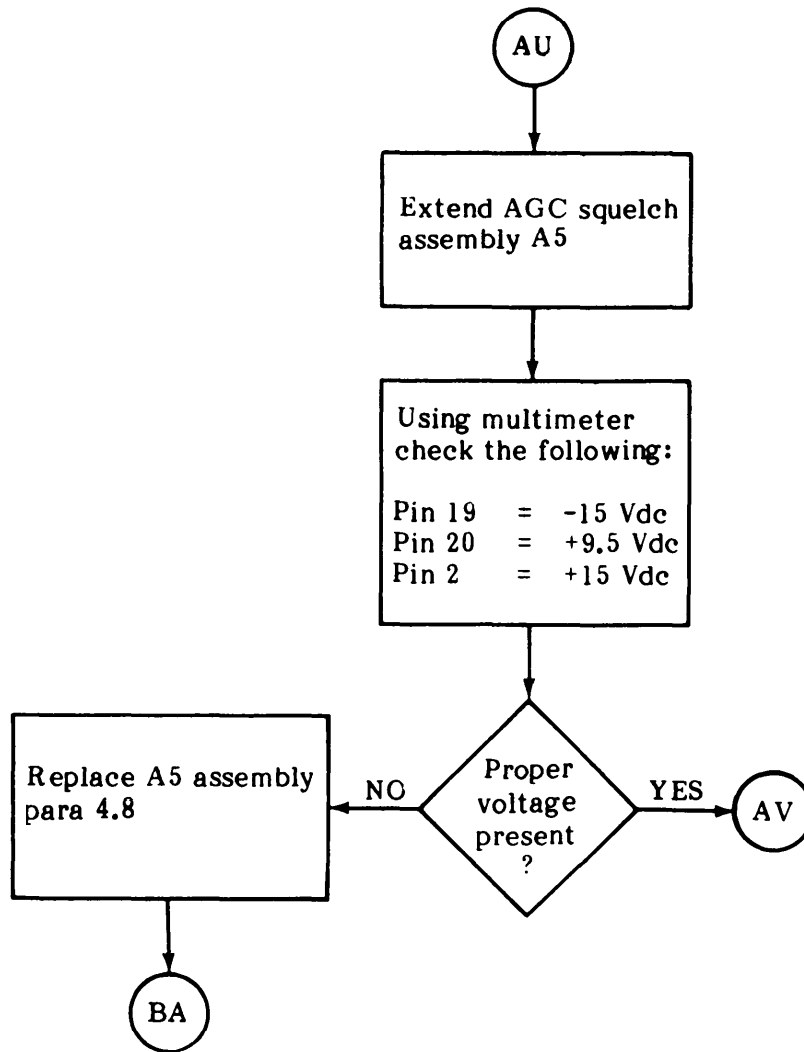


TABLE 4-1







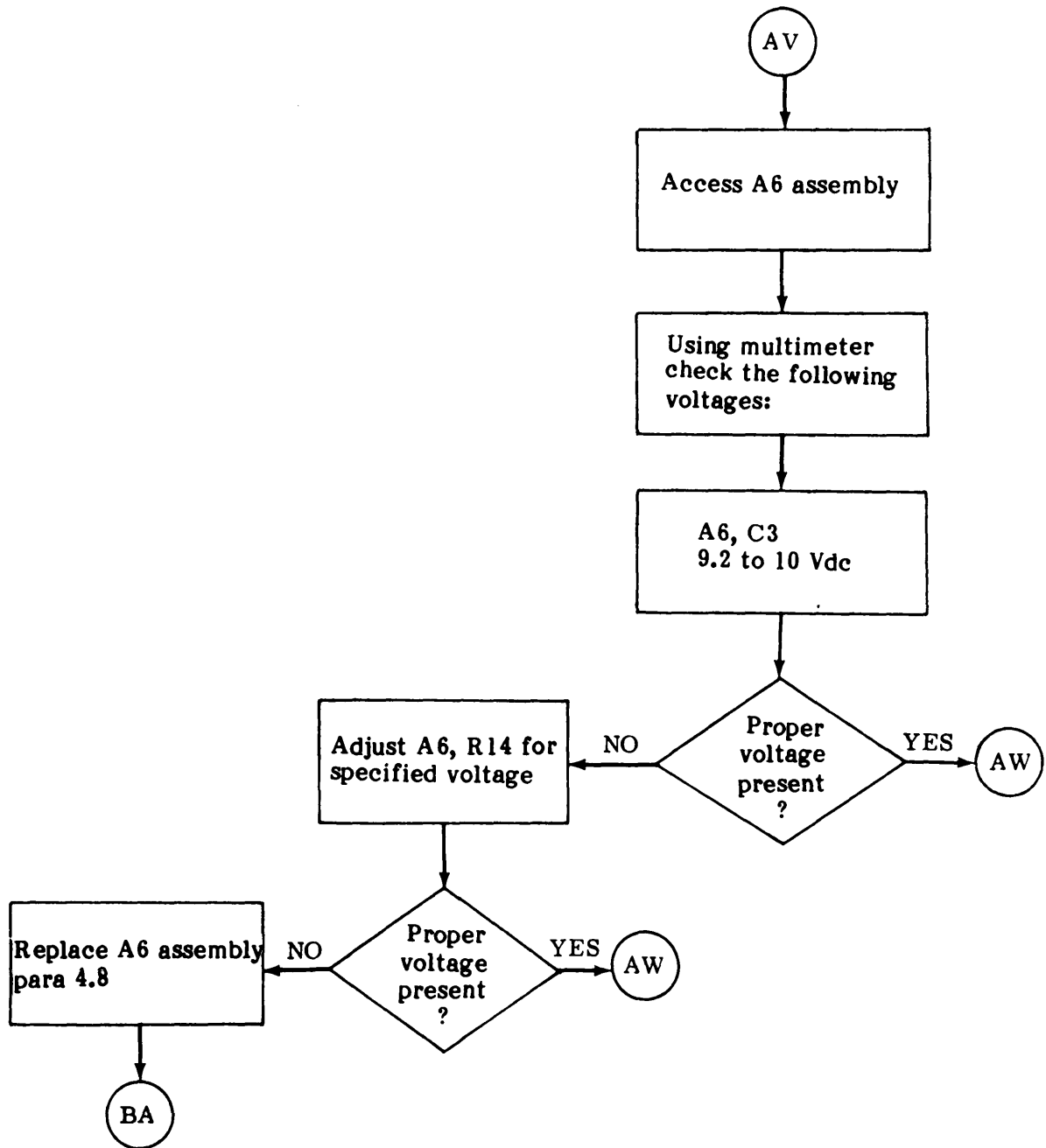
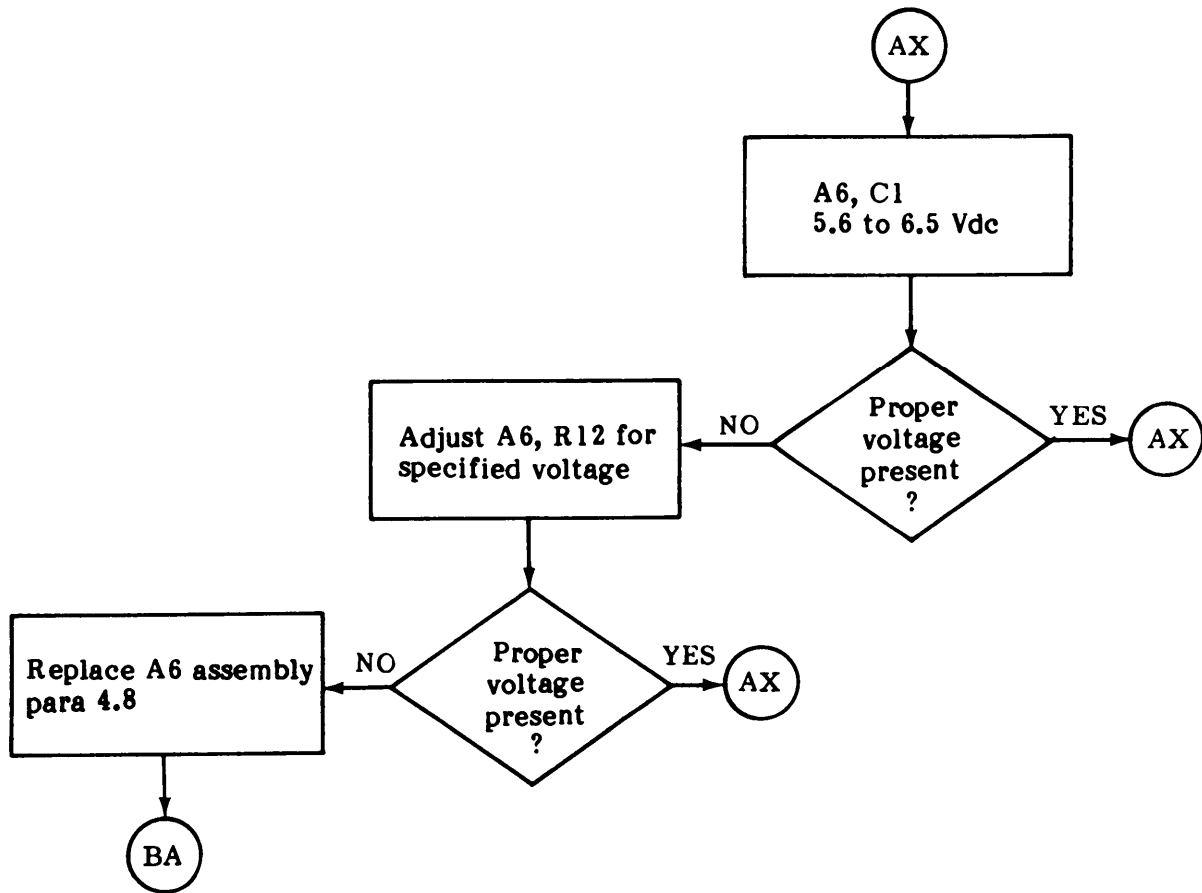
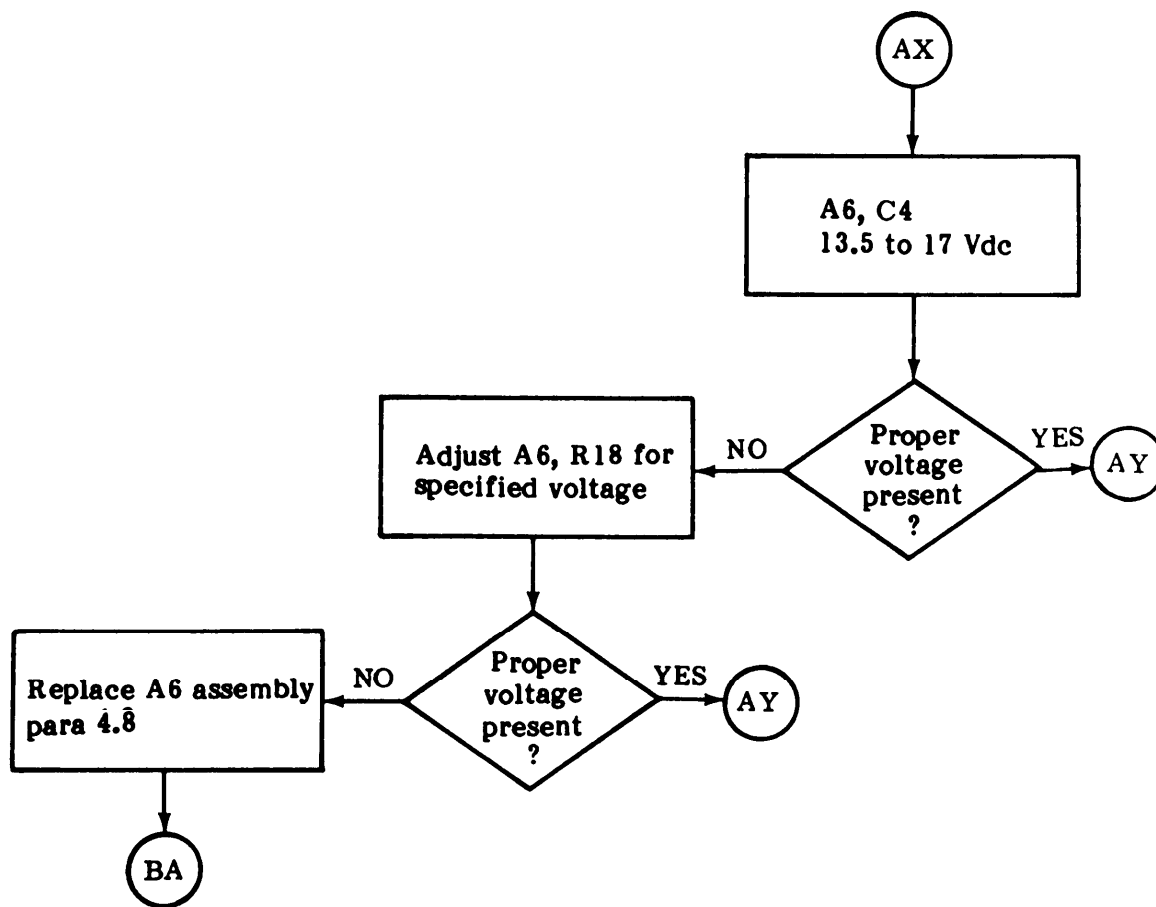
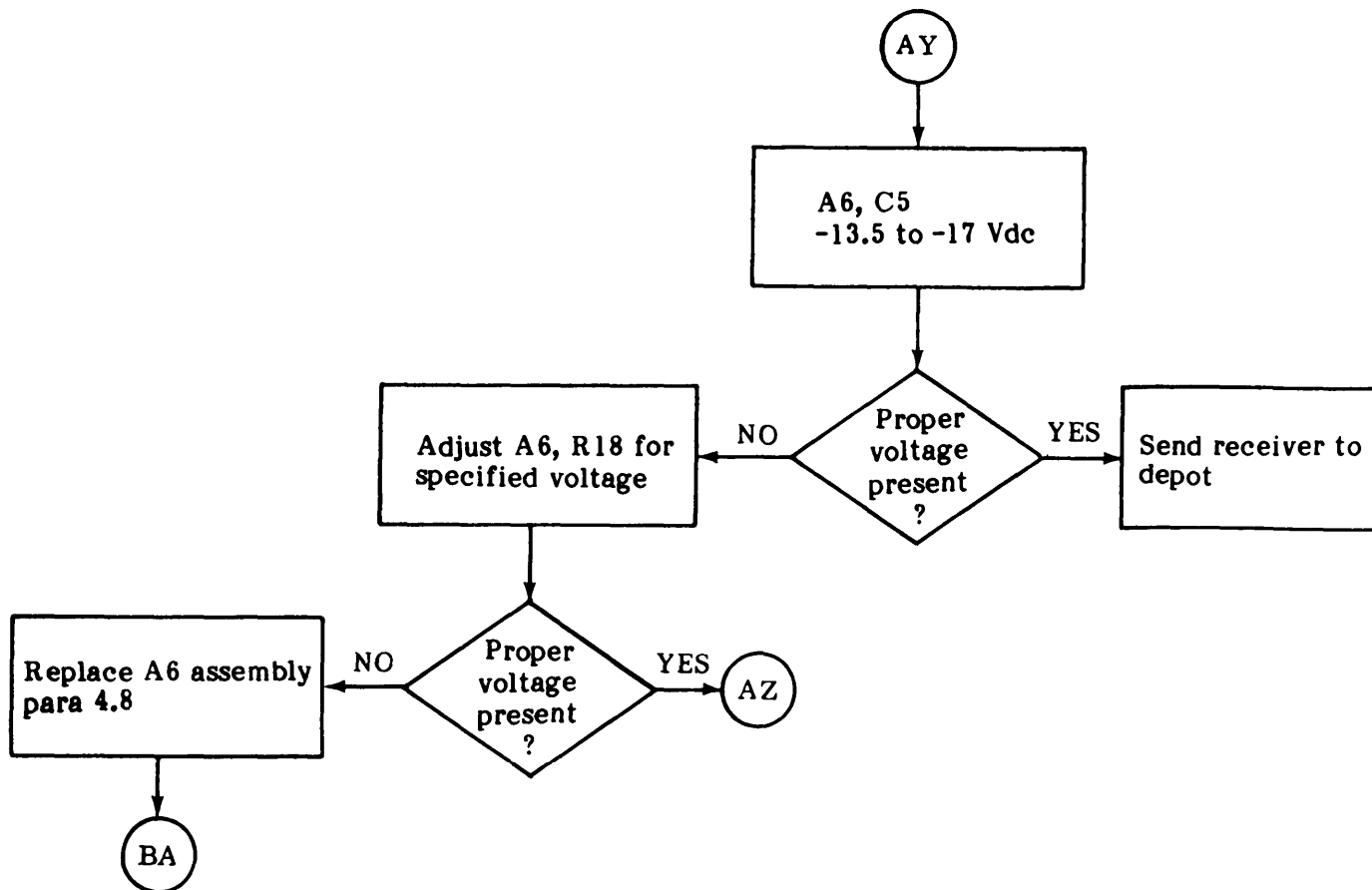


TABLE 4-1







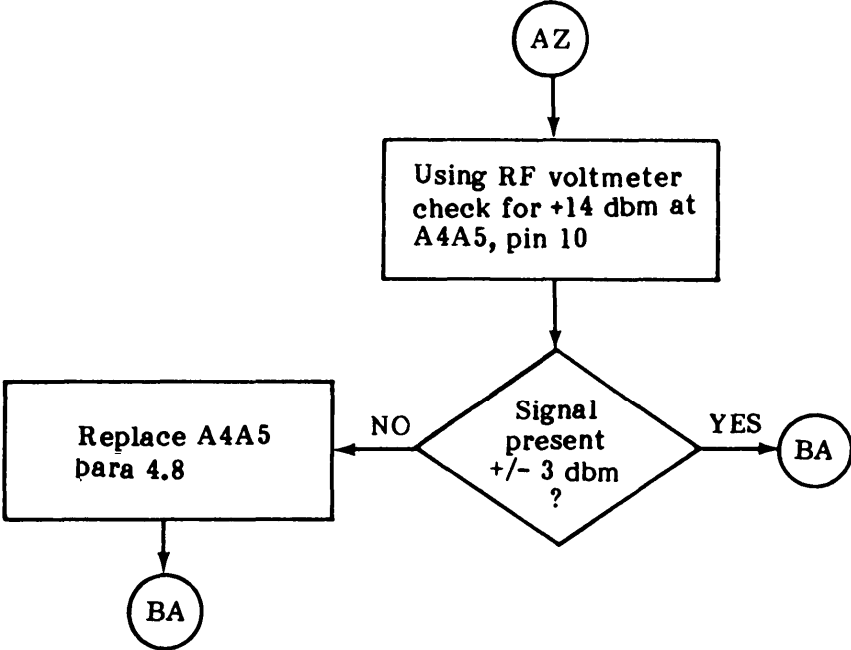
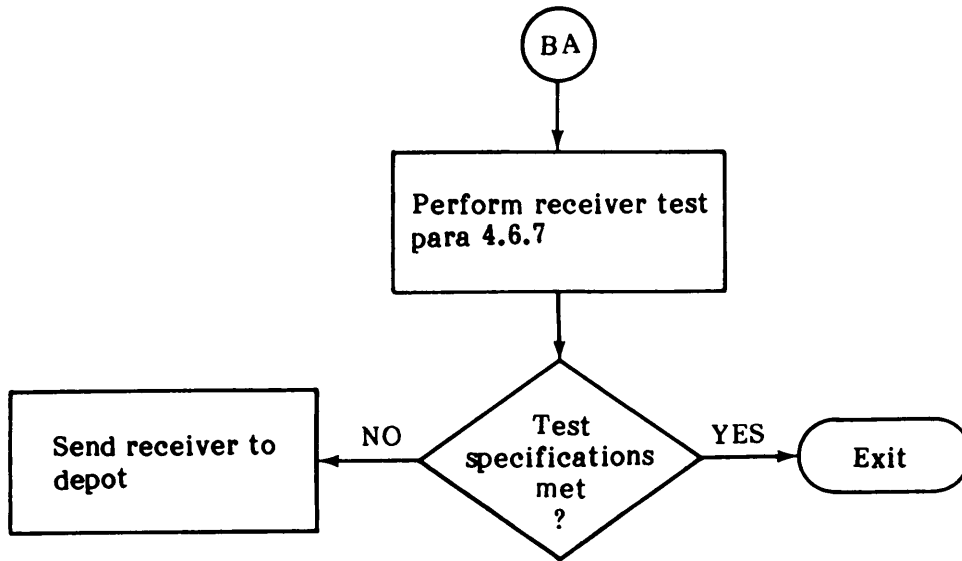


TABLE 4-1



NO AUDIO AND NO SIGNAL INDICATION ON SIGNAL STR METER WHEN HIGH BAND IS SELECTED

INITIAL SETUPTest Equipment

| | |
|---------------------------------|--|
| Multimeter | AN/PSM-45 |
| Test Lead Set | Simpson 00577 |
| Signal Generator | SG-1112(V) 1/U w/options 001,002 and 003 |
| Cable, RF, 50 ohms, 4', BNC-BNC | HP 10503A |
| RF Voltmeter | Boonton 92C |
| High Frequency Probe | Boonton 91-12F |
| 50 ohm Adapter | Boonton 91-8B |
| Power Supply | PP-6547/U |

Tools

| | |
|-----------------------------|------------------|
| 4 Inch Flat Tip Screwdriver | 5120-00-222-8852 |
| No. 1 Phillips Screwdriver | 5120-00-240-8716 |
| Card Extender | 791212 |
| 3/32 OpenEndWrench | 5120-00-132-0486 |

Replacement Parts

| | |
|--------------------------------|--|
| DC-DC Converter | 791794 |
| Cable (W1) | 17300-148-1 |
| Antenna Switch (A1) | 791783 |
| Cable (W3) | 17300-148-3 |
| Tuner (A2) | TN-584/GRR-8(V), TN-585/GRR-8(V) or TN-586/GRR-8(V) |
| Cable (W5) | 17300-148-5 |
| 21.4 - 10 RHz Converter (A4A1) | 794021 |
| Cable (W7) | 17300-148-7 |

Equipment Condition

POWER Switch (S7) set to ON
 BAND (MHz) switch set to HIGH BAND
 Receiver tuned to 150 MHz
 MODE switch (S5) set to AM
 RF GAIN (R5) fully clockwise (not in AGC)
 VOLUME control (R 10) set to mid-range
 IF BANDWIDTH switch (S4) set to 50 kHz
 Front cover speaker connected to J4
 Receiver cover removed
 Signal generator set to 150 MHz CW @ -30 dbm
 Signal generator connected to RF IN (J1)
 RF voltmeter referenced to signal generator and set to read-25 dbm
 RF voltmeter connected to SM OUTPUT (J2)
 Power supply set to 24 Vdc
 Power supply connected to J5
 WJ-9121 [TN-5884/GRR8(V)] Tuner installed

Courtesy of <http://BlackRadios.terryo.org>

NOTE

Level readings given reflect the use of the Boonton 91-8B 50 OHM adapter for all cable and connector measurements and the use of the Boonton 91-12F probe with tip at all circuit board measurements.

Minimum of 30 minutes warm-up time is required prior to starting troubleshooting procedures.

Courtesy of <http://BlackRadios.terryo.org>

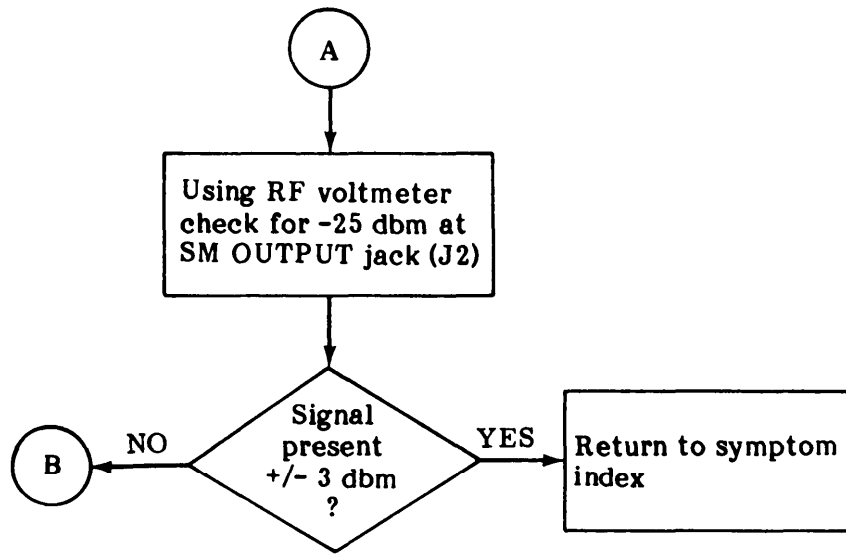
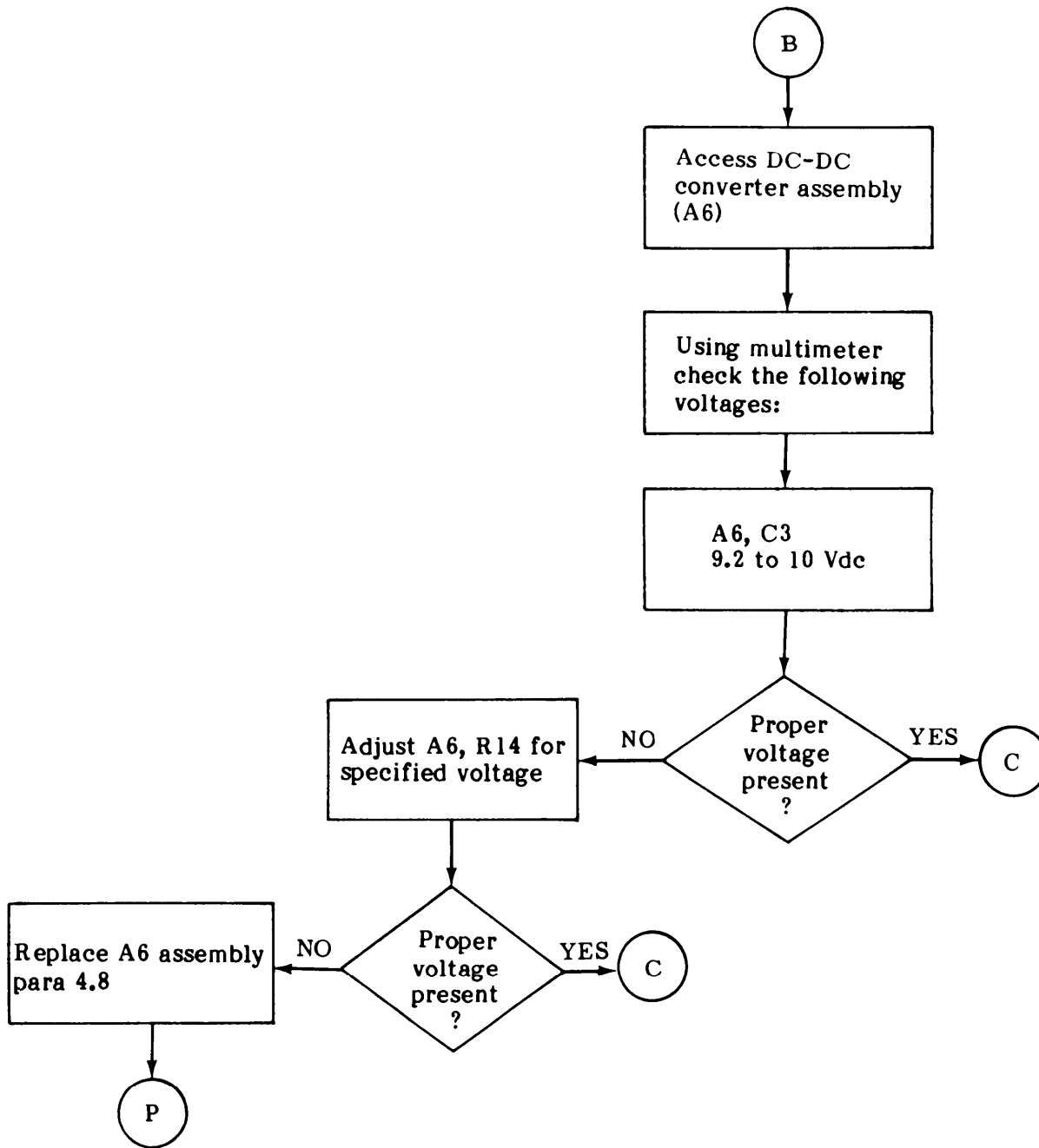
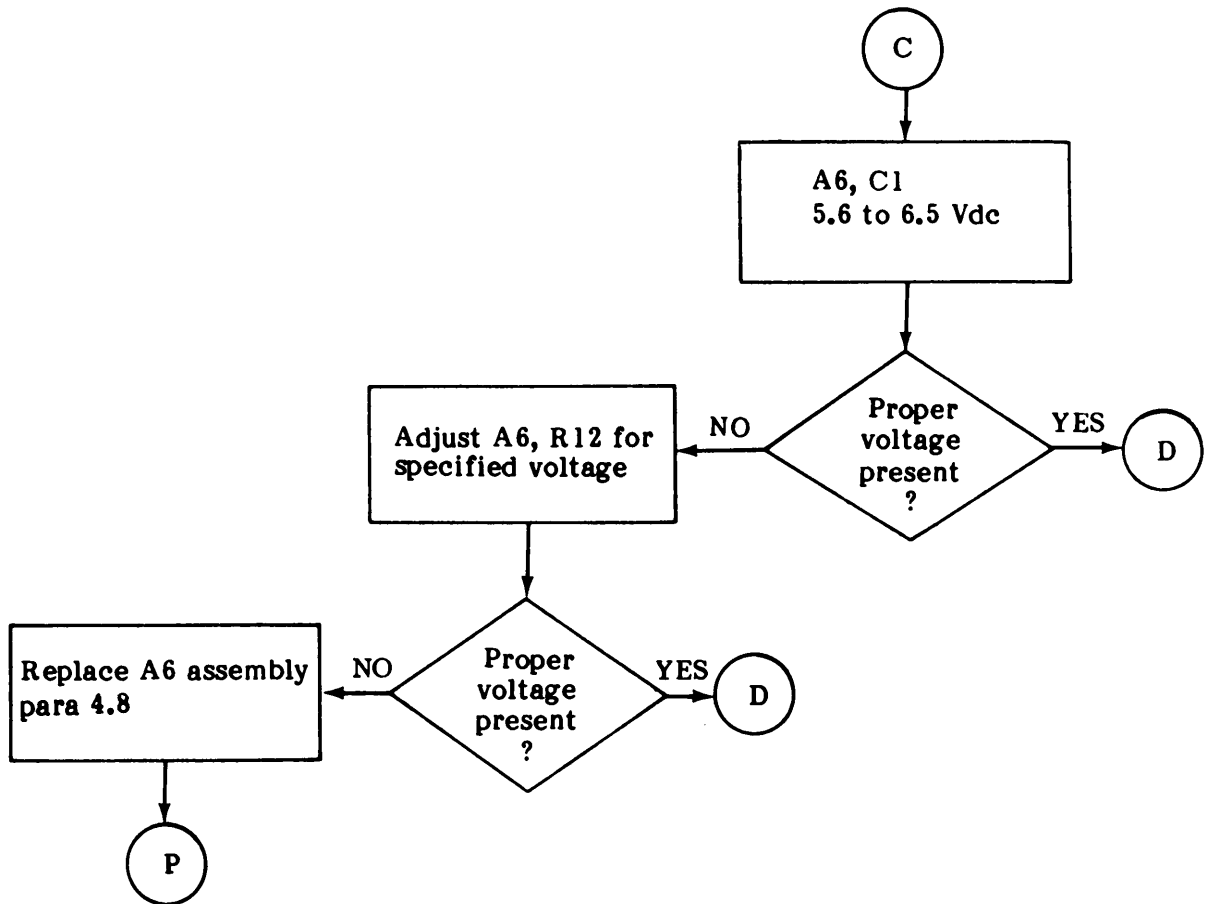
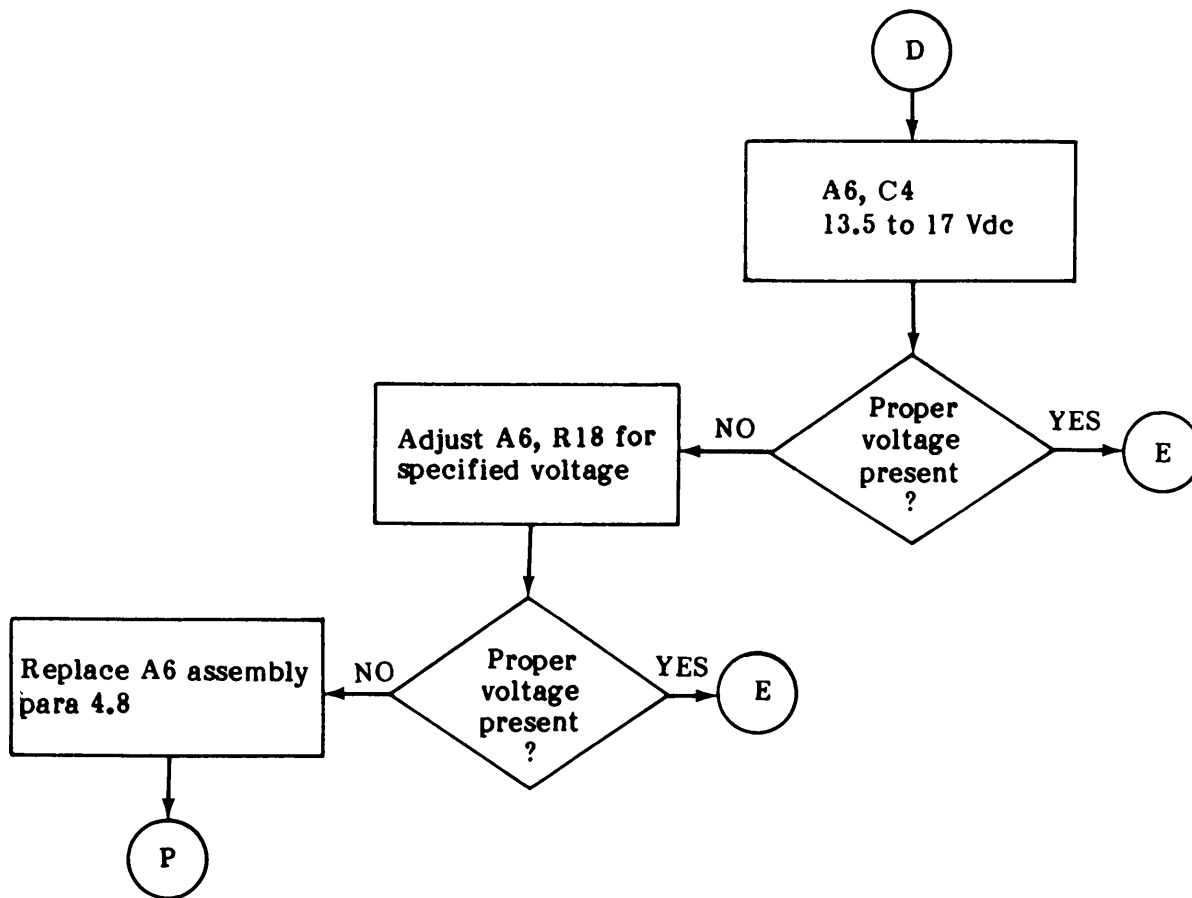


TABLE 4-1







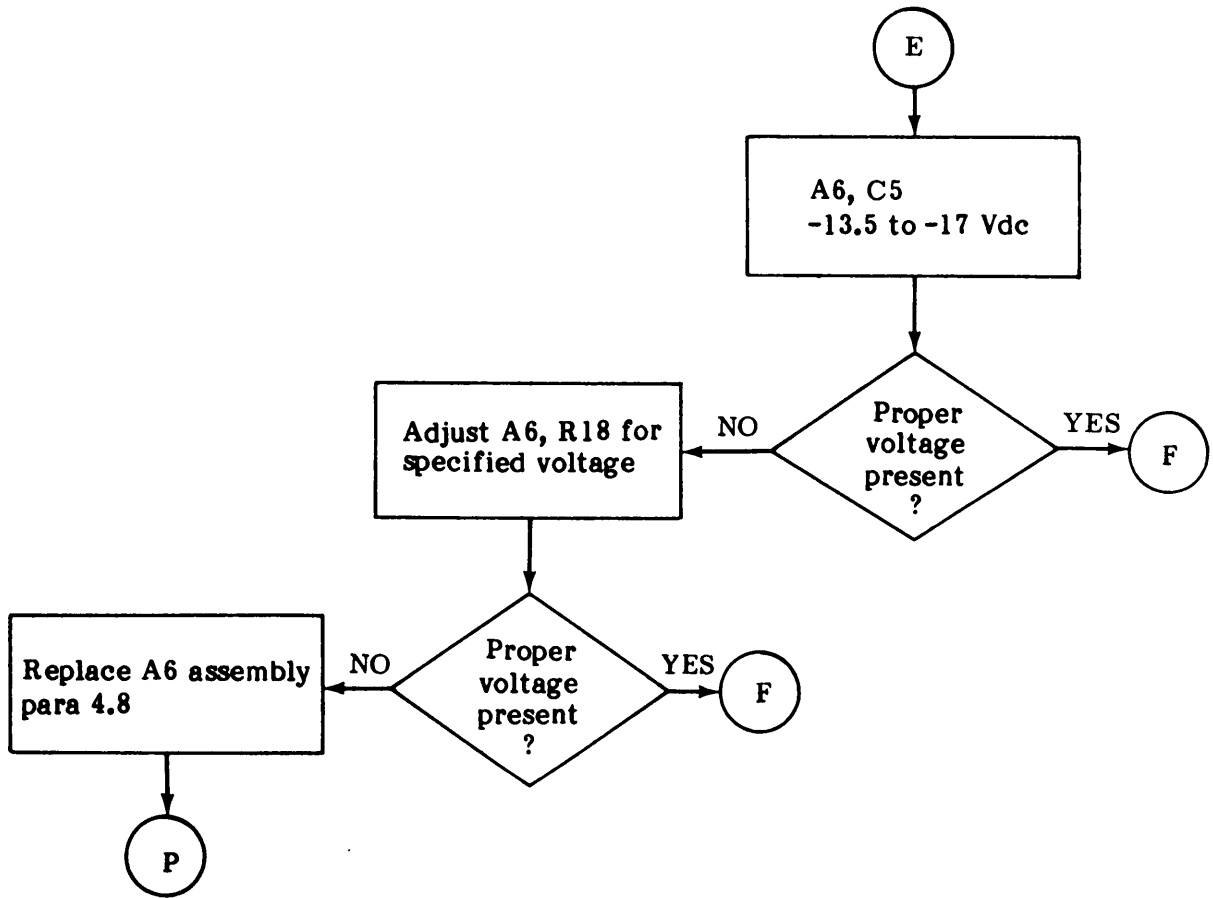
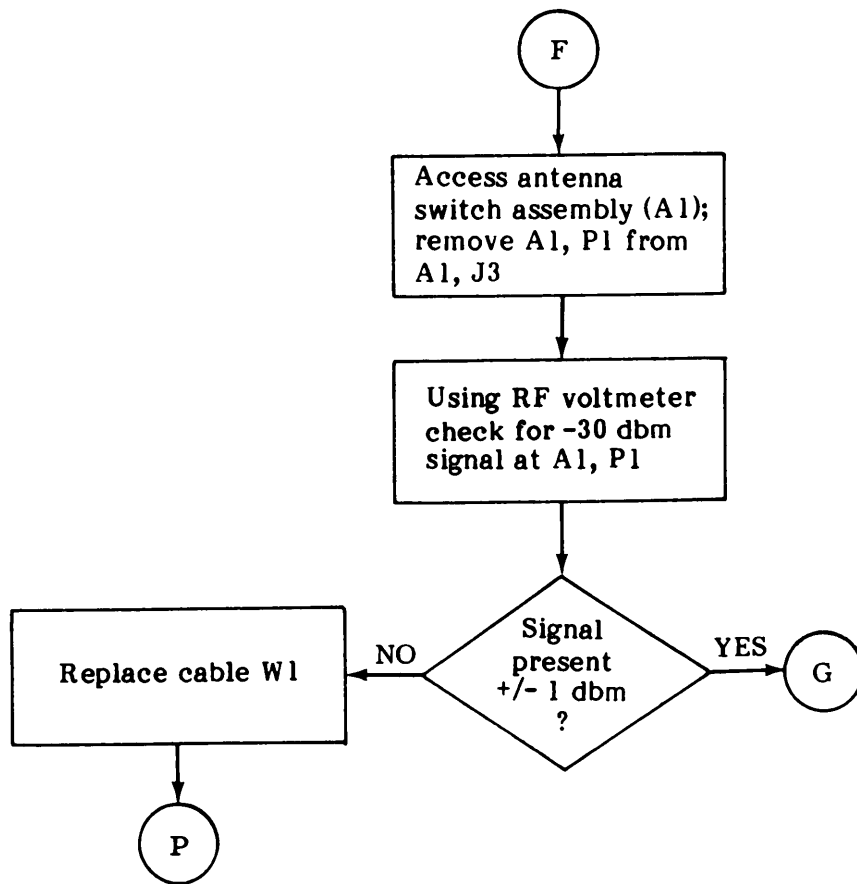


TABLE 4-1



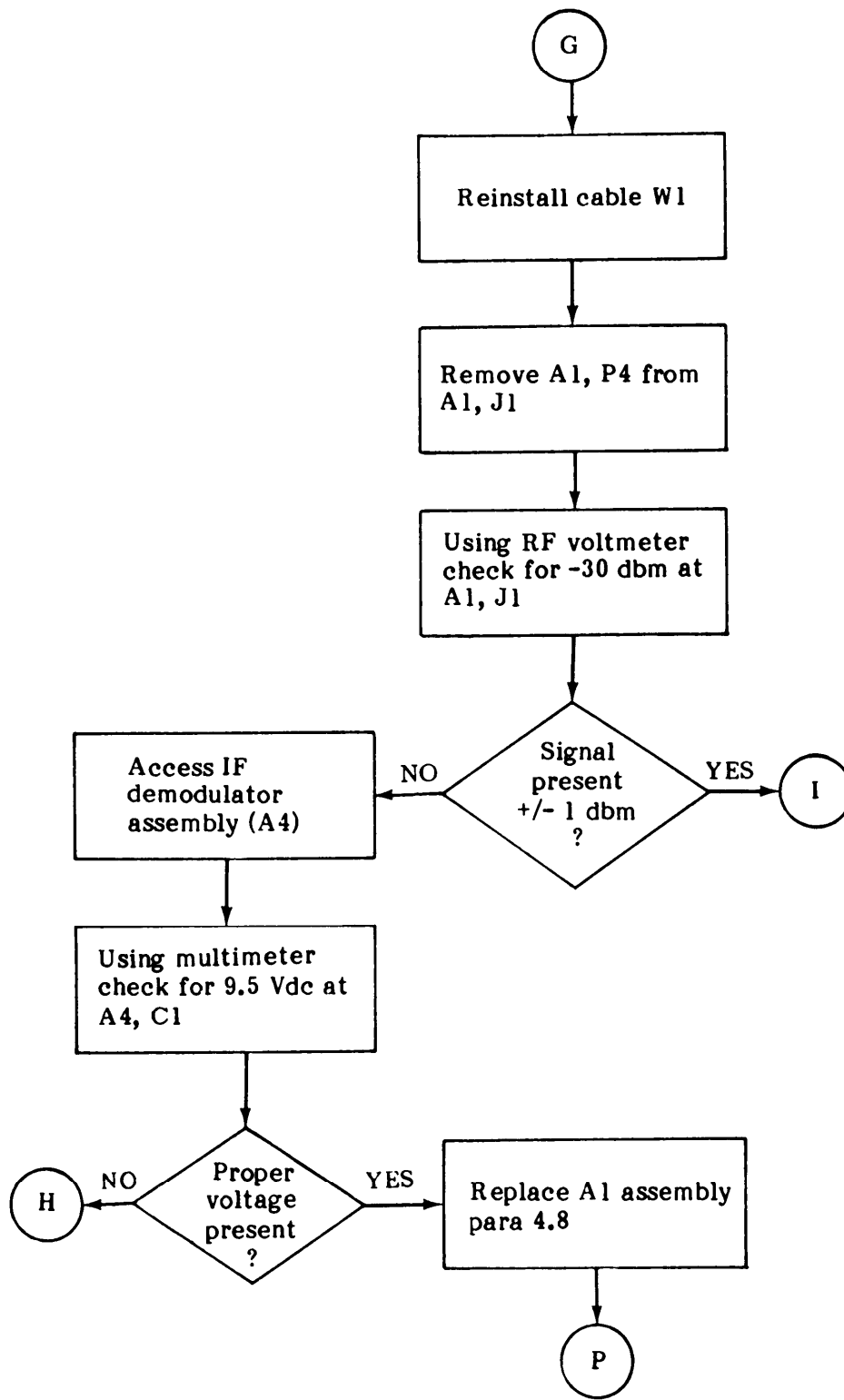
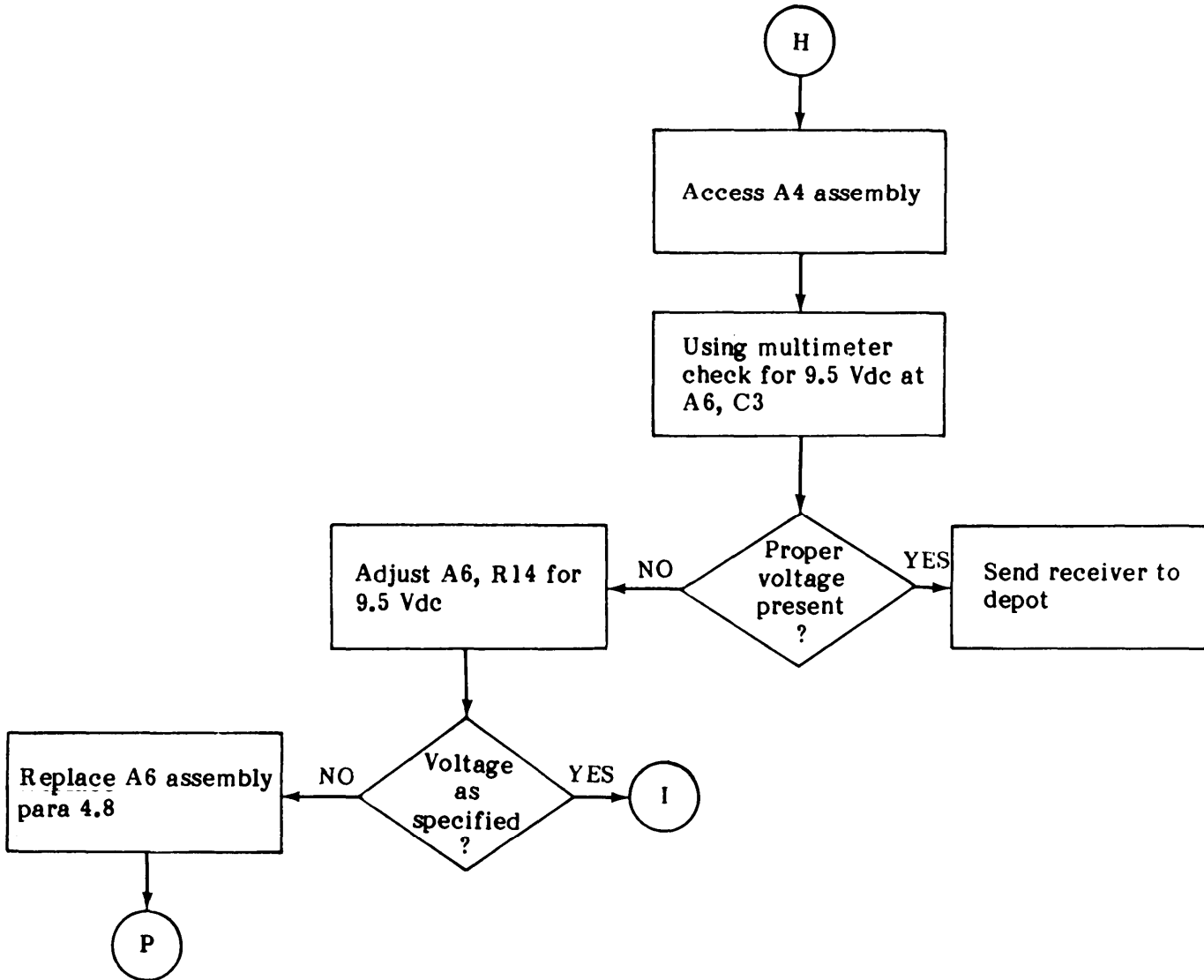
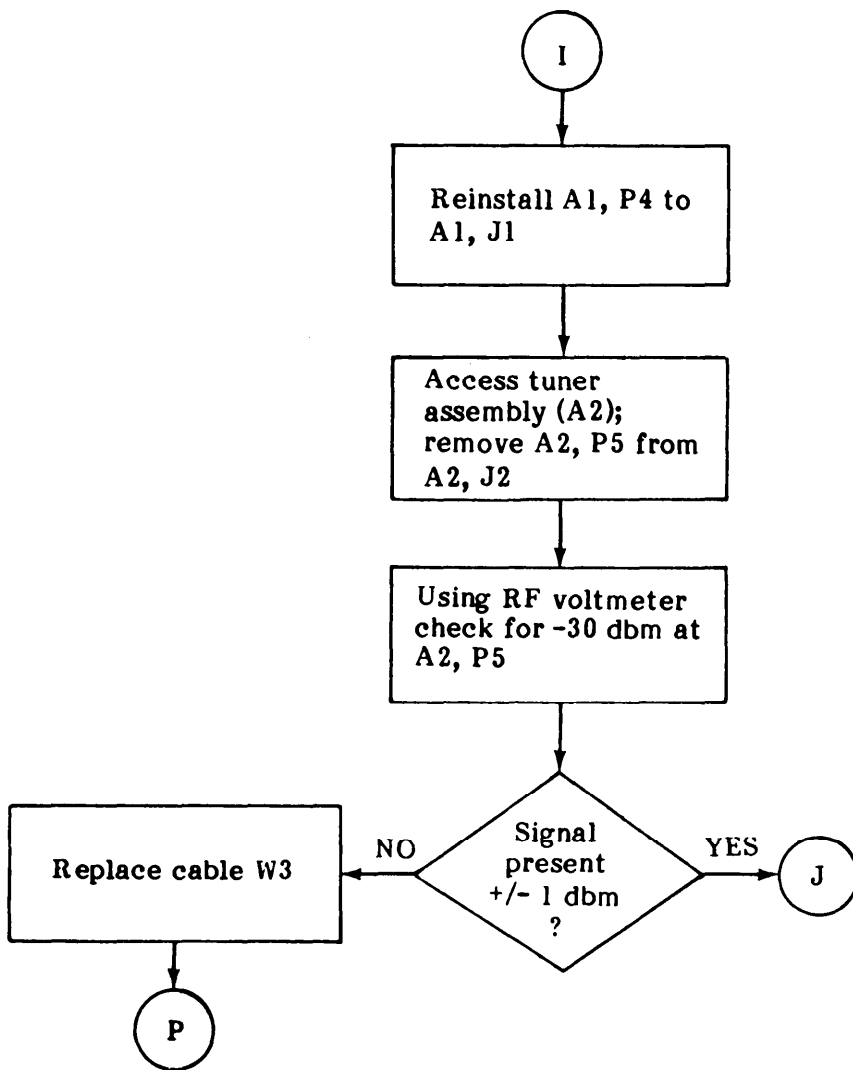
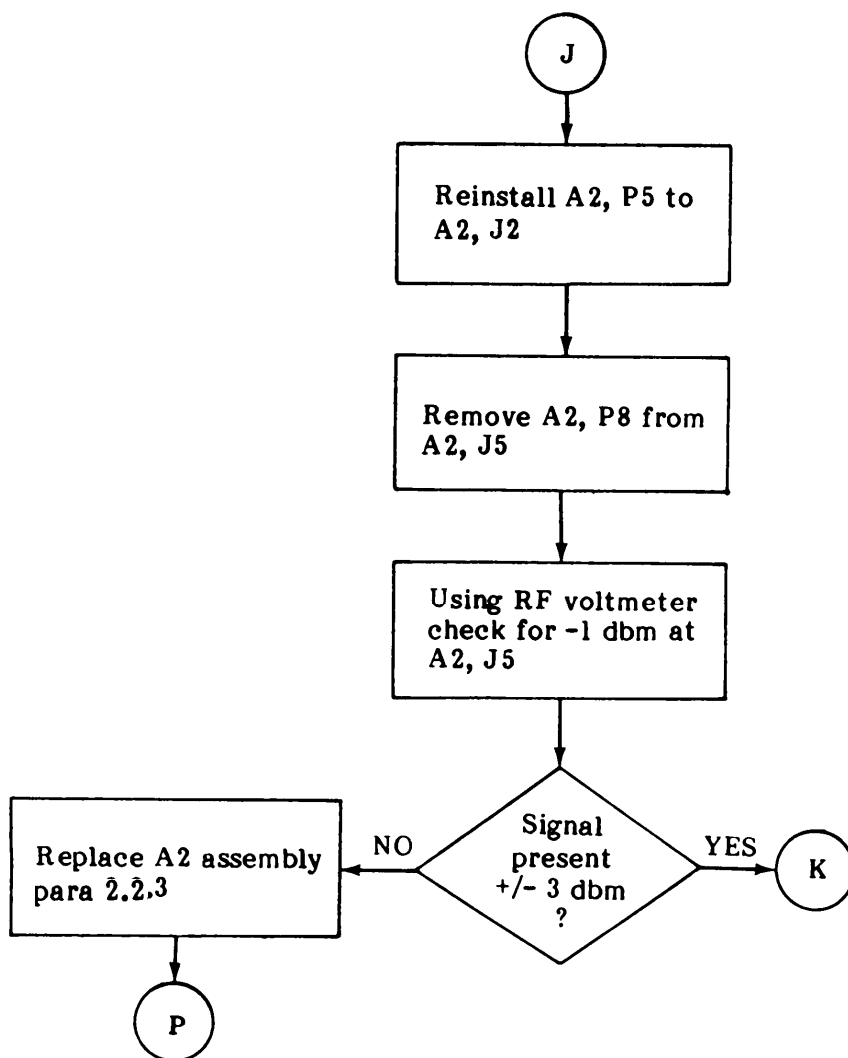


TABLE 4-1







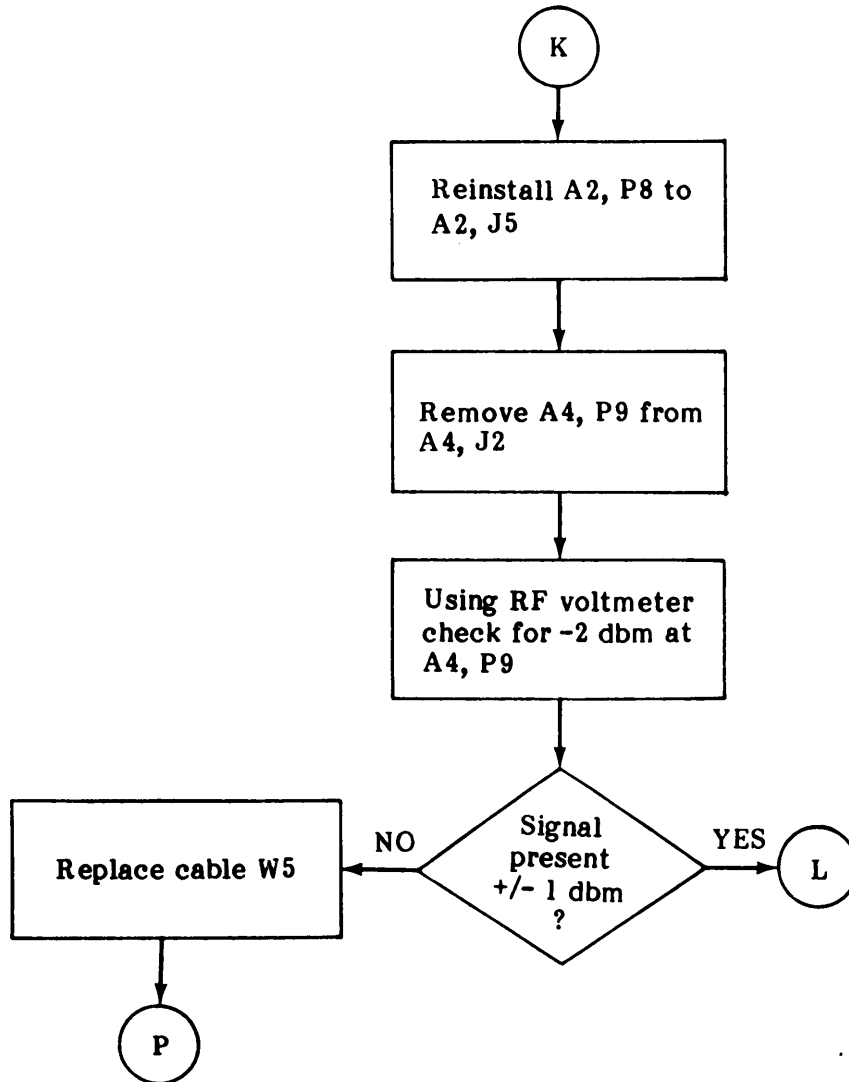
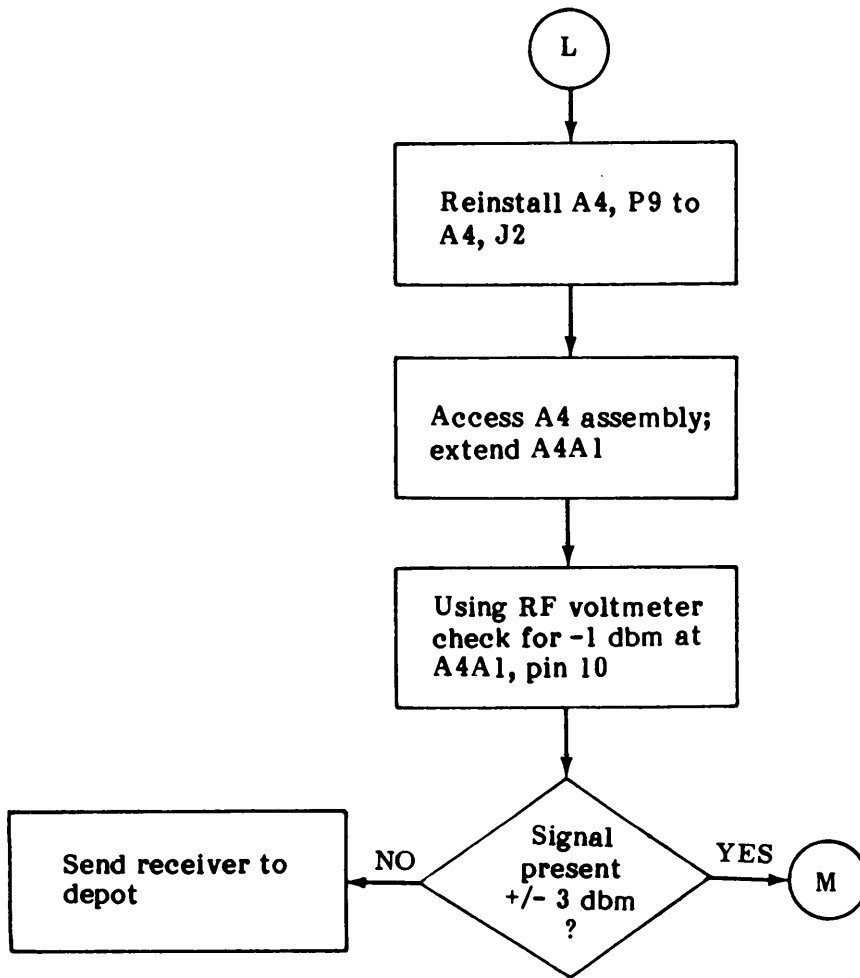


TABLE 4-1



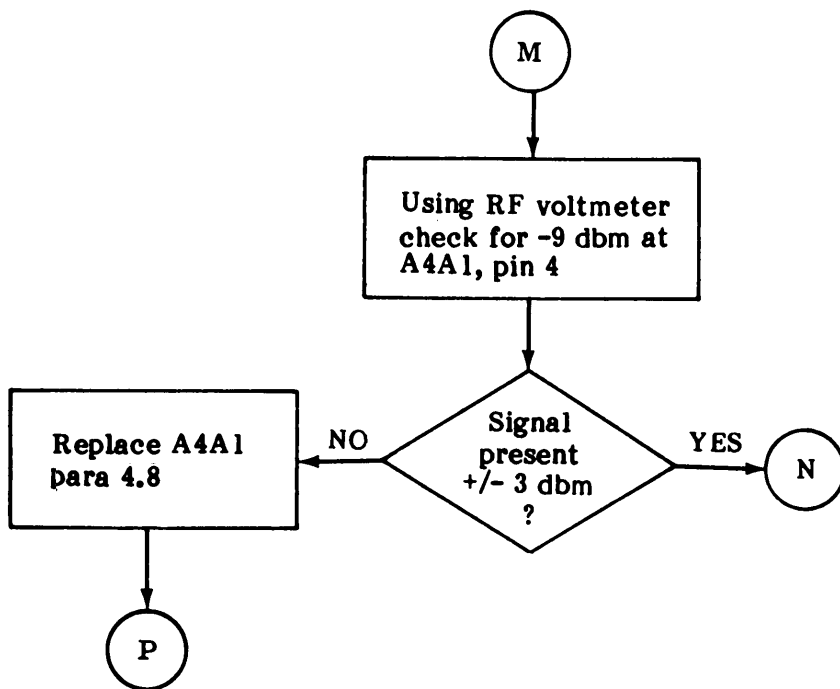
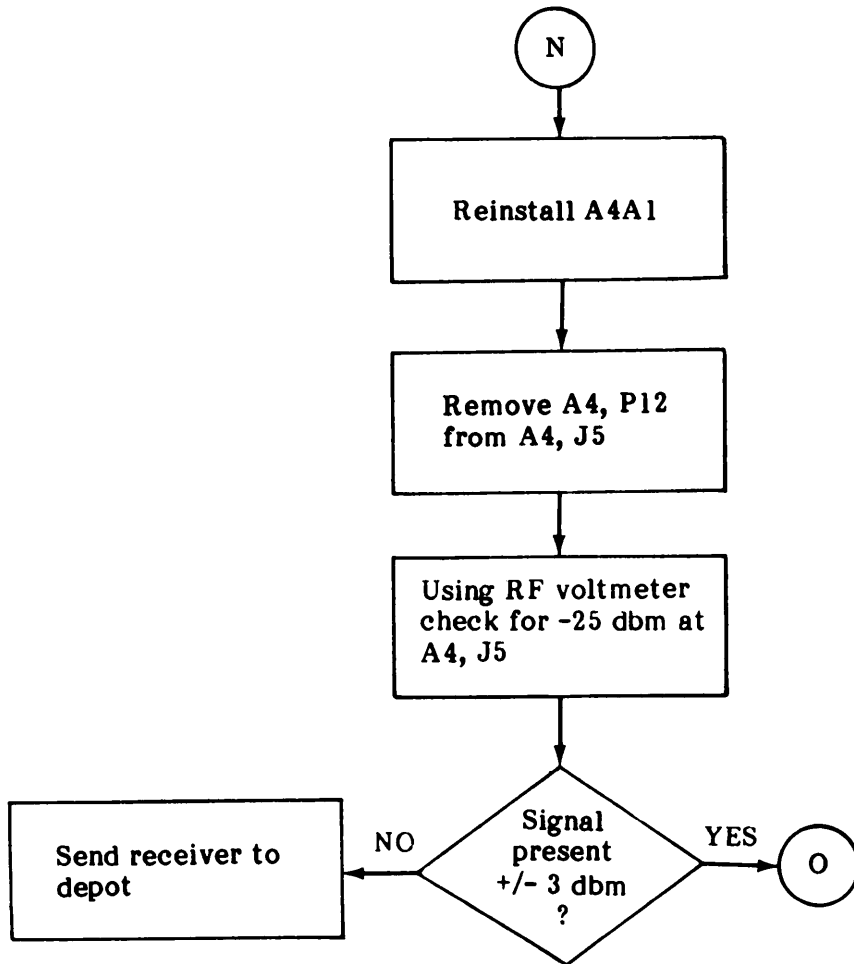
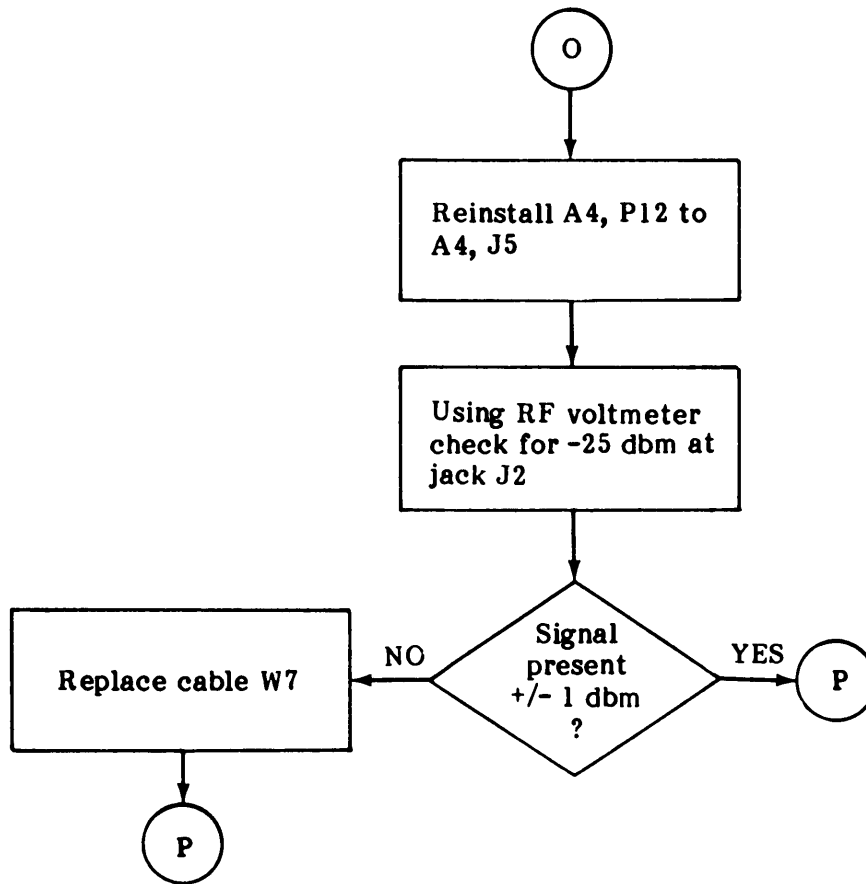
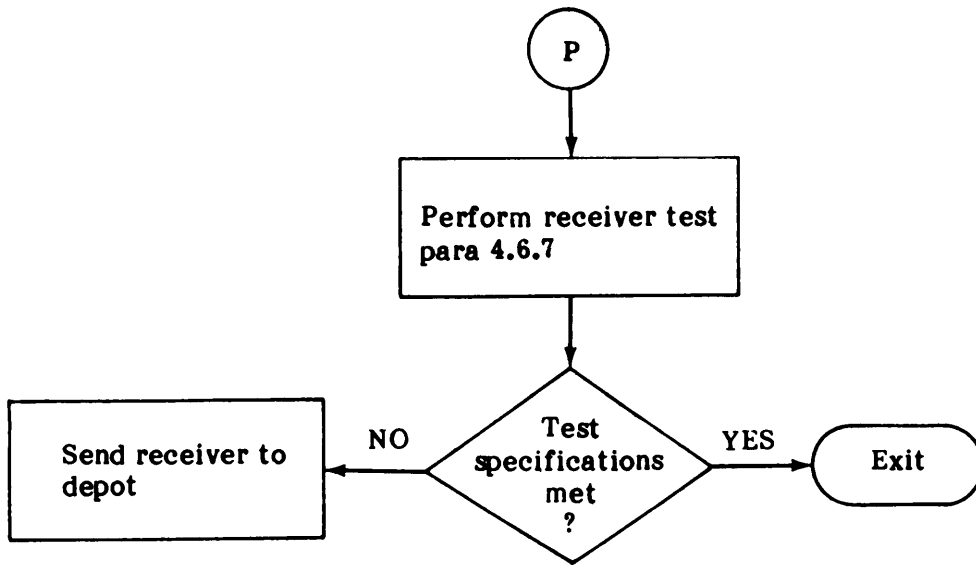


TABLE 4-1







NO AUDIO AND NO SIGNAL INDICATION ON SIGNAL STR METER WHEN LOW BAND IS SELECTED

INITIAL SETUP

Test Equipment

Multimeter
AN/PSM-45
Test Lead Set
Simpson 00577
Signal Generator
SG-1112(V) I/U w/options 001, 002

and 003
Cable, RF, 50 ohms, 4', BNC-BNC
HP 10503A
RF Voltmeter
Boonton 92C
High Frequency Probe
Boonton 91-12F
50 ohm Adapter
Boonton 91-8B
Power Supply
DD-6547/U

Tools

4 Inch Flat Tip Screwdriver
5120-00-222-8852
No. 1 Phillips Screwdriver
5120-00-240-8716
7/32 Inch Open End Wrench
5120-00-132-0486
Card Extender
791212

Replacement Parts

DC-DC Converter (A6)
791794
Cable (W1)
17300-148-1
Antenna Switch (A 1)
791783
Cable (W2)
17300-148-2
Tuner (A2)
TN-584/GRR-8(V), TN-585/GRR-8(V)

or TN-586/GRR-8(V)
Cable (W4)
17300-148-4
21.4-10 MHz Converter (A4A1)
794021
Cable (W7)
17300-148-7

Equipment Condition

POWER switch (S7) set to ON
BAND (MHz) switch (S8) set to HIGH BAND
Receiver tuned to 150 MHz
MODE switch (S5) set to AM
RF GAIN (R5) fully clockwise (not in AGC)
VOLUME control (R 10) set to mid-range
IF BANDWIDTH switch (S4) set to 10 KHz
Front cover speaker connected to J4
Receiver cover removed
Signal generator set to 150 MHz C W @ -30 dbm
Signal generator connected to RF IN (J1)
RF voltmeter referenced to signal generator and set to read -25 dbm
RF voltmeter connected to SM OUTPUT (J2)
Power supply set to 24 Vdc
Power supply connected to J5
WJ-99121 [TN-584/GRR8(V)] Tuner installed

NOTE

Level readings given reflect the use of the Boonton 91-8B 50 OHM adapter for all cable and connector measurements and the use of the Boonton 91-12F probe with tip at all circuit board measurements

Minimum of 30 minutes warm-up time is required prior to starting troubleshooting procedures

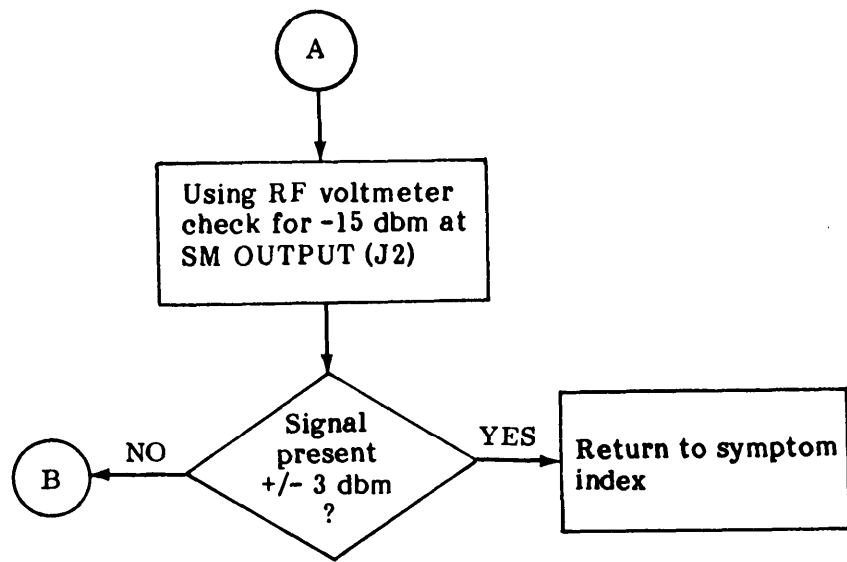
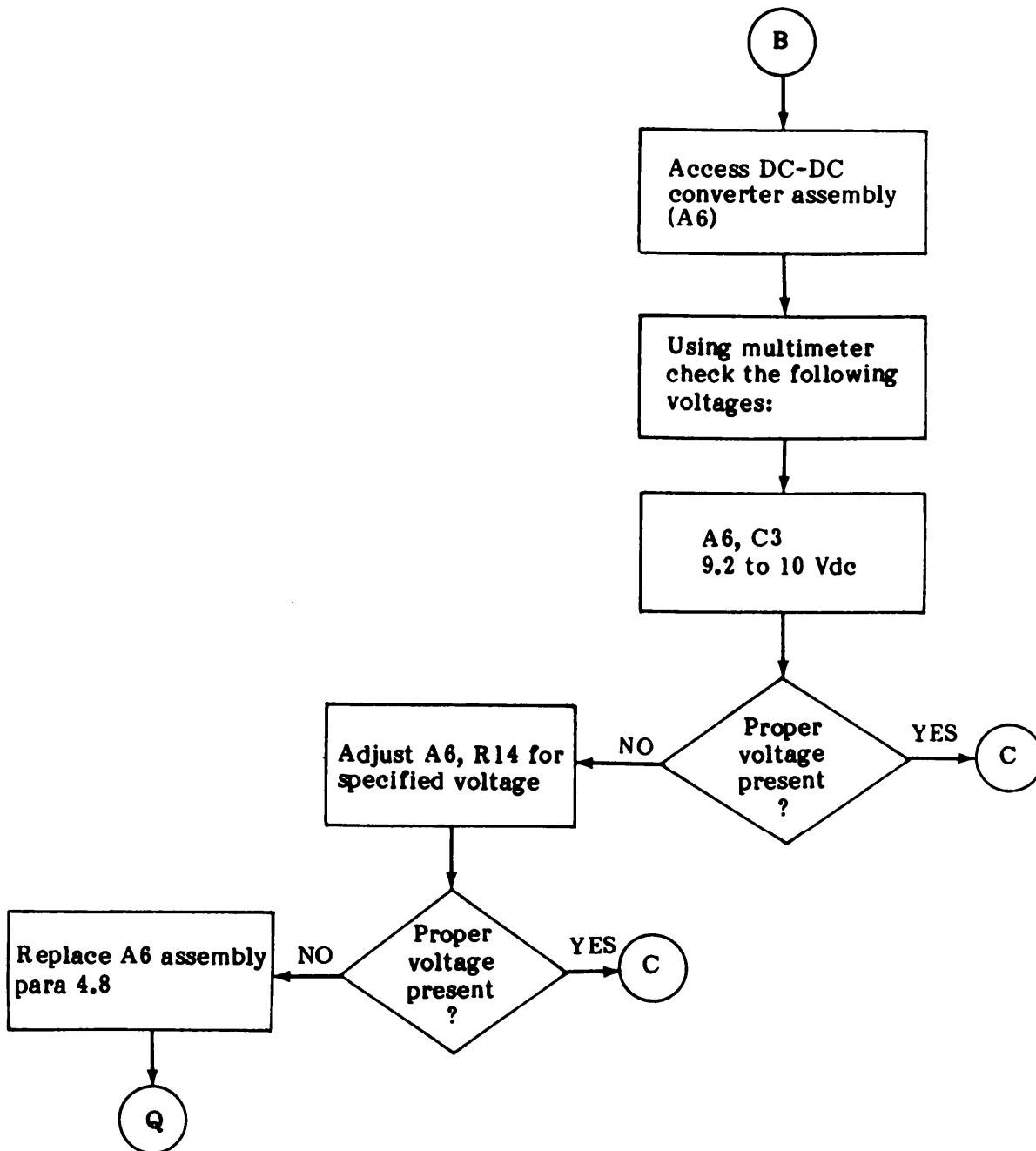
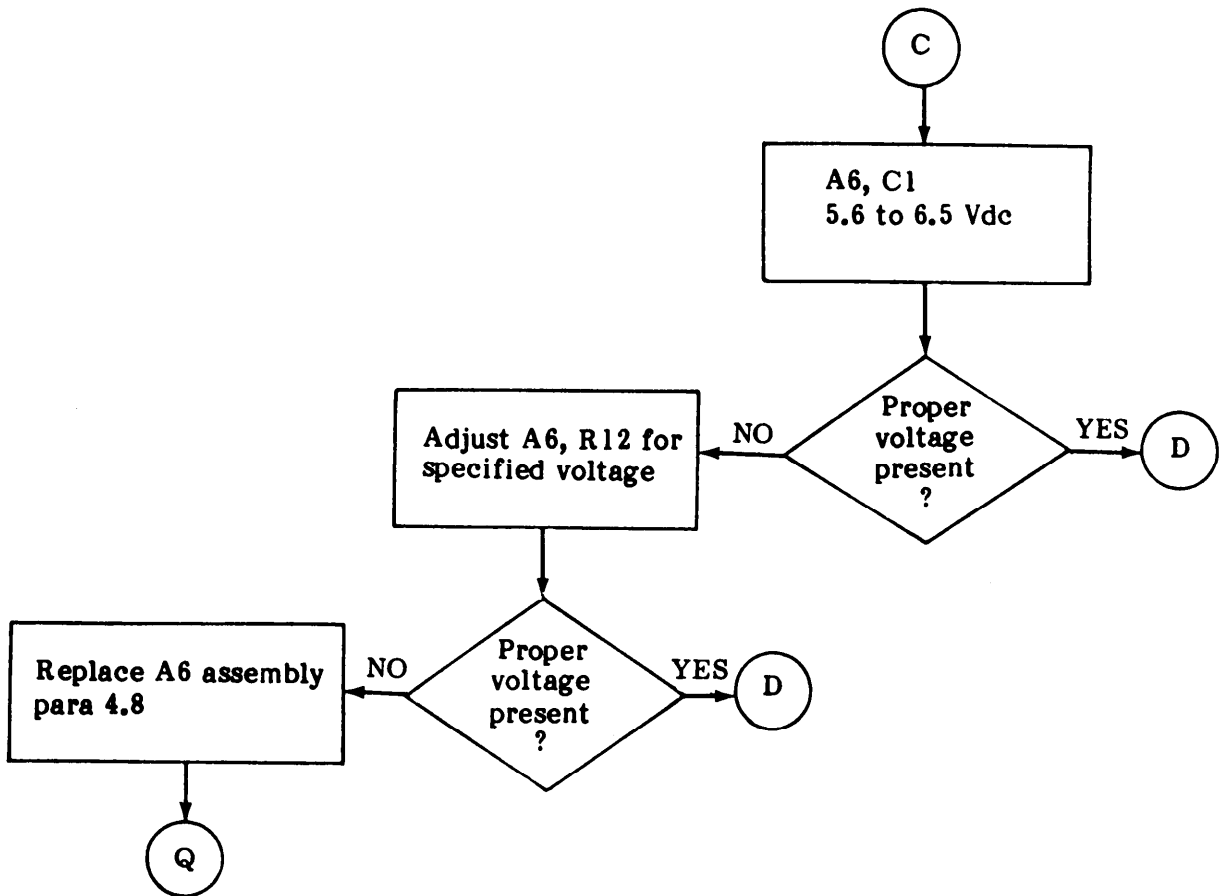
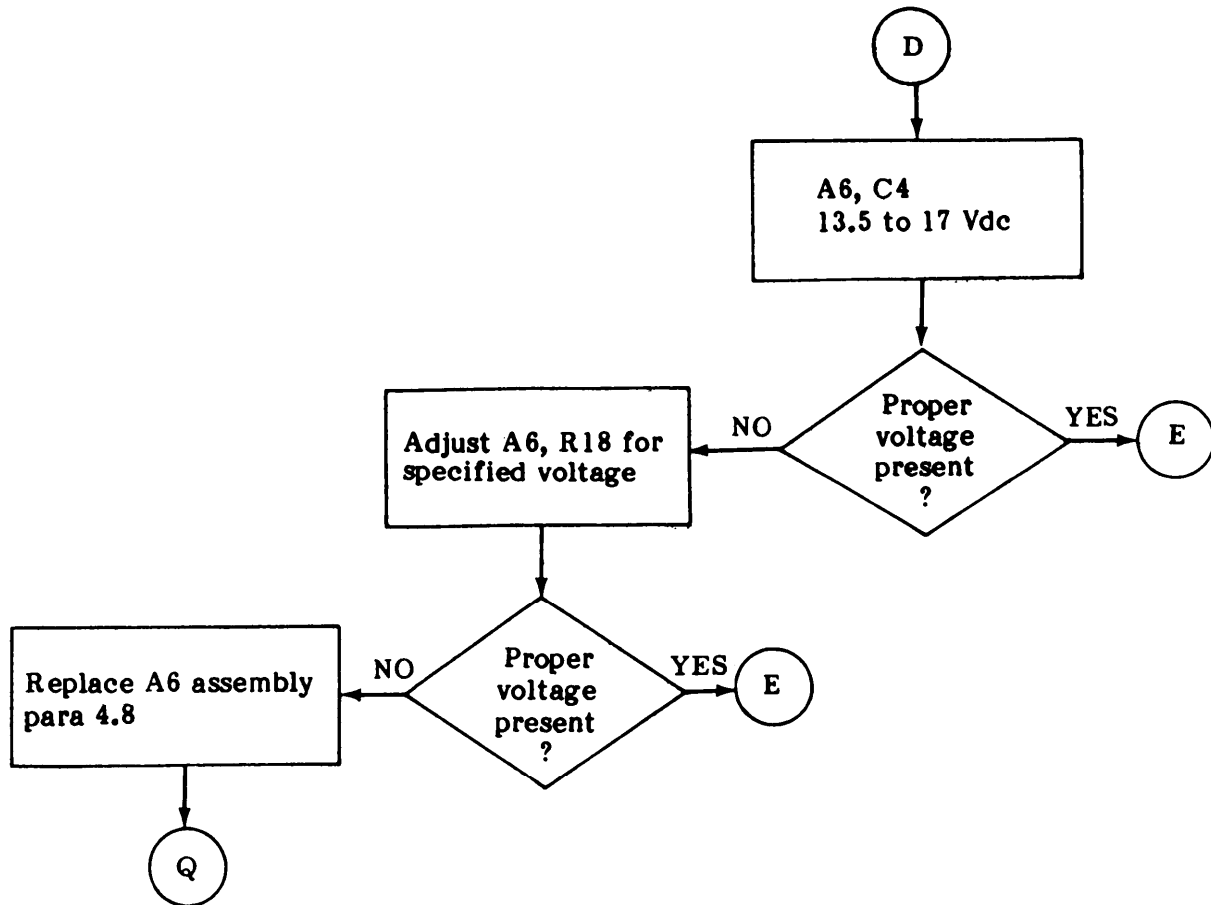


TABLE 4-1







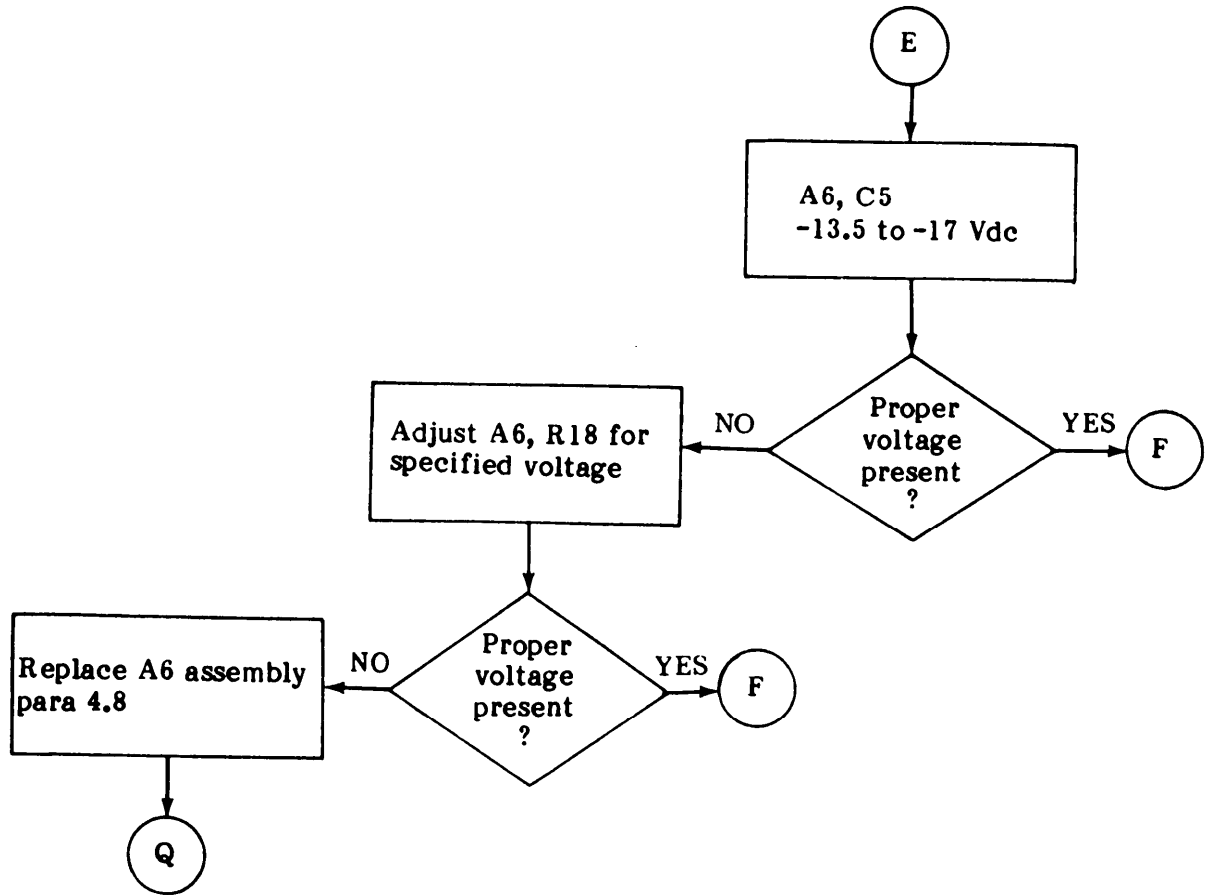
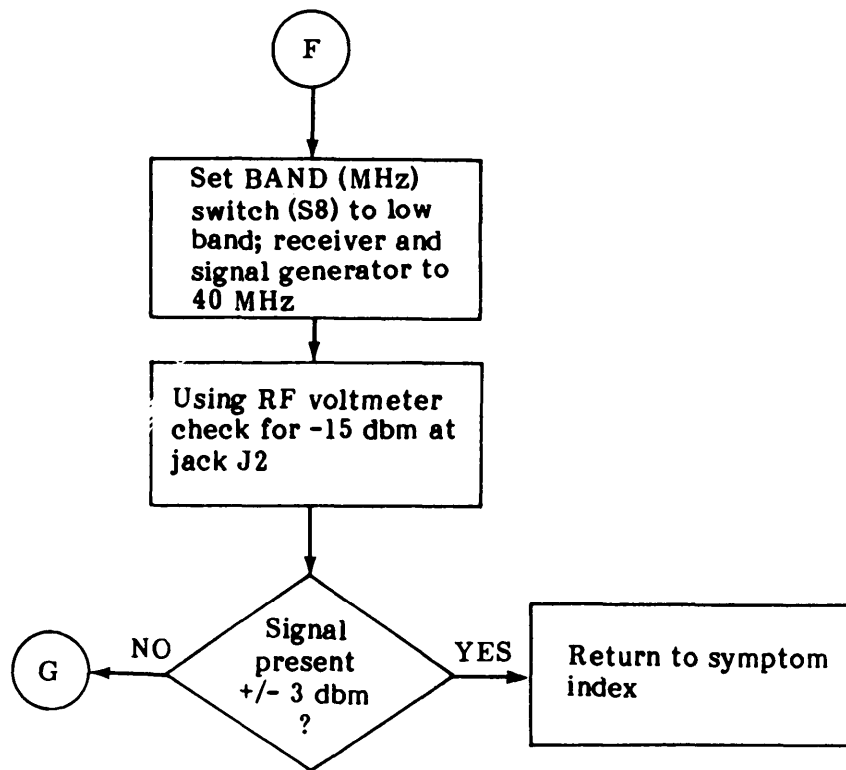


TABLE 4-1



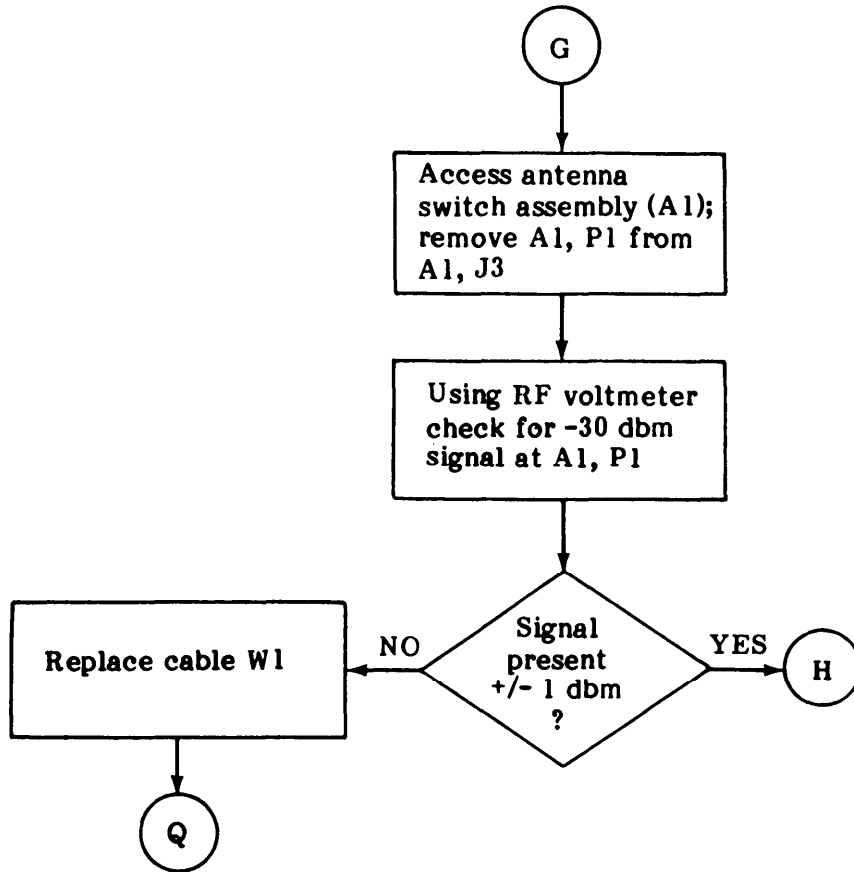
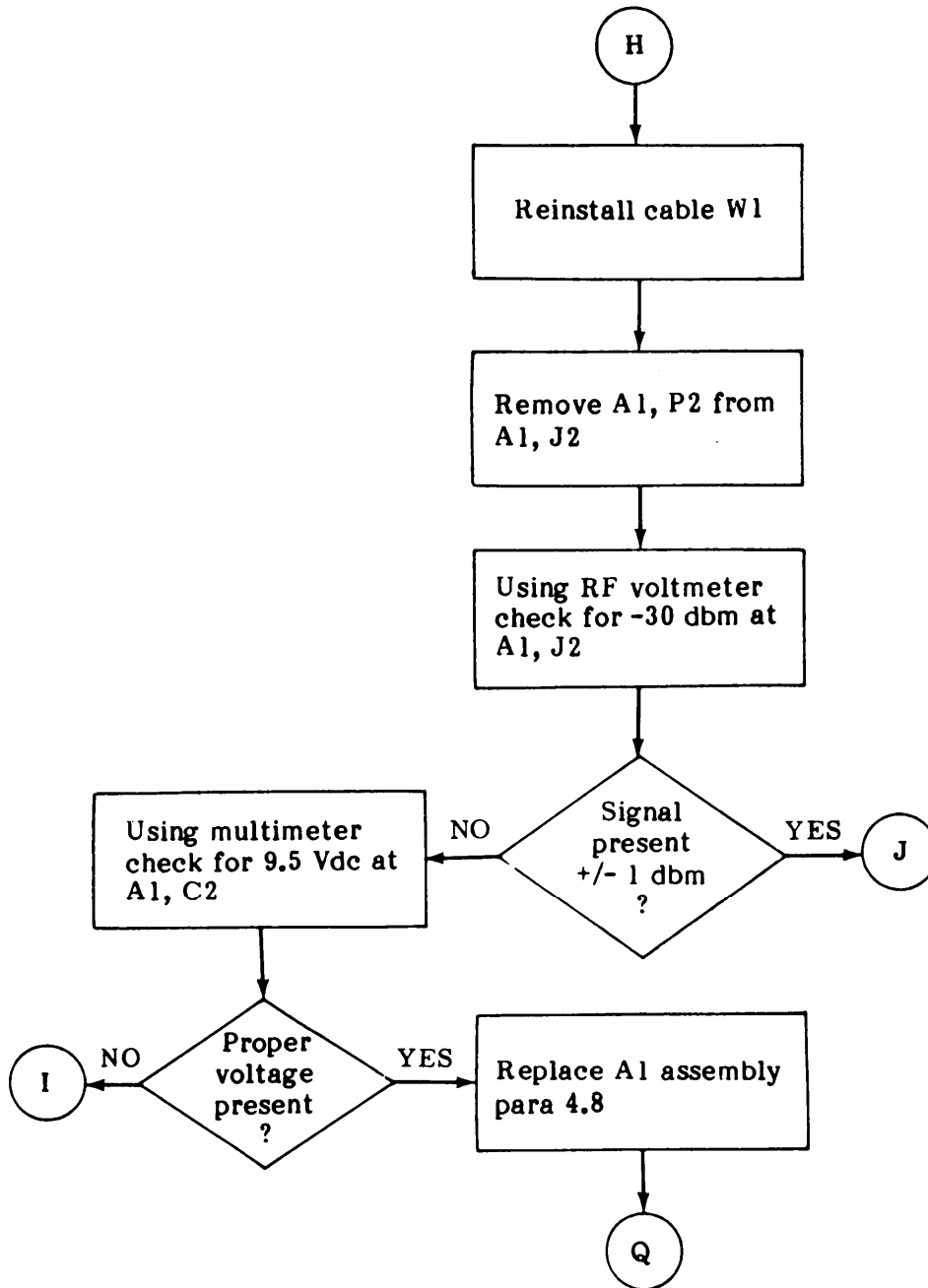
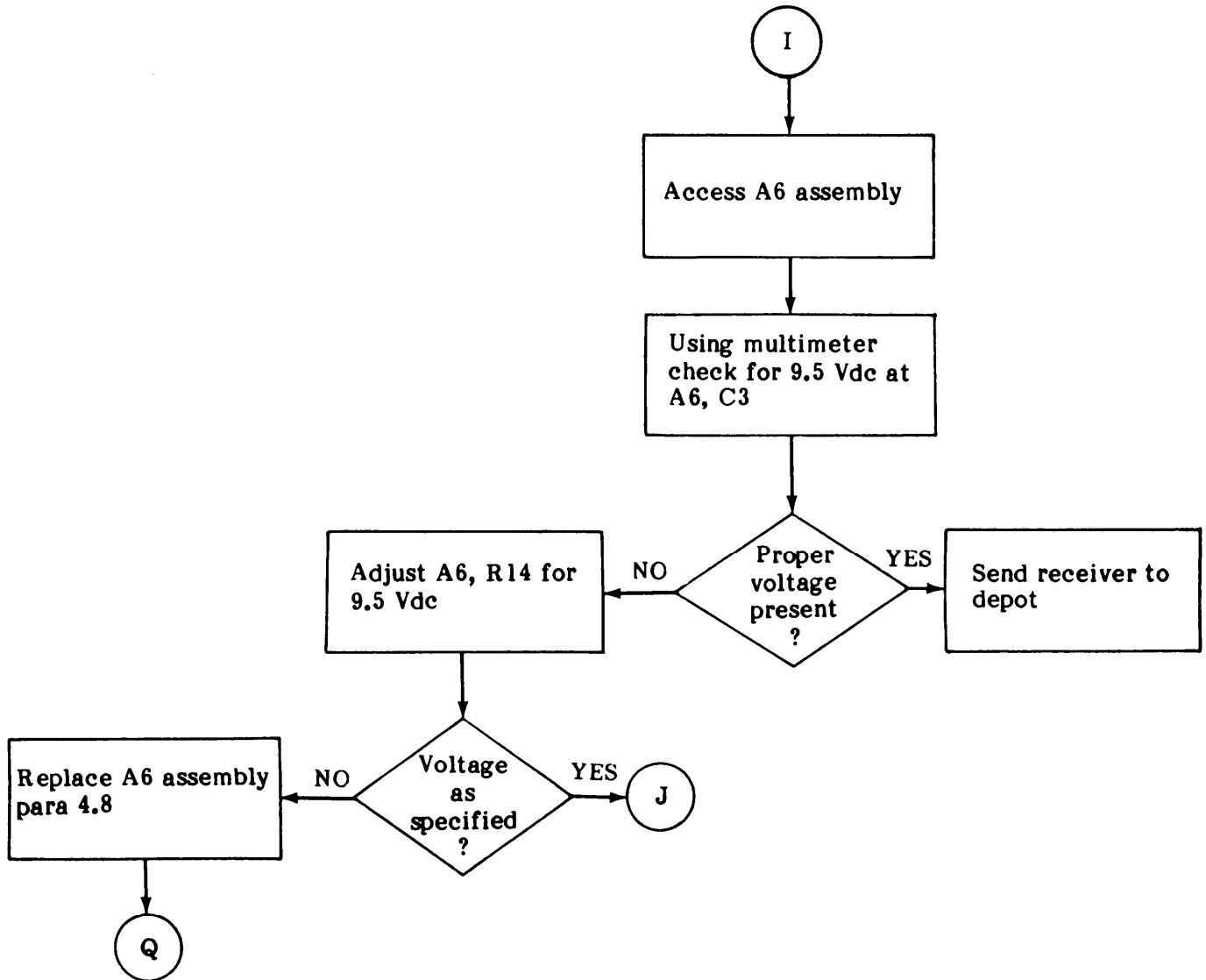
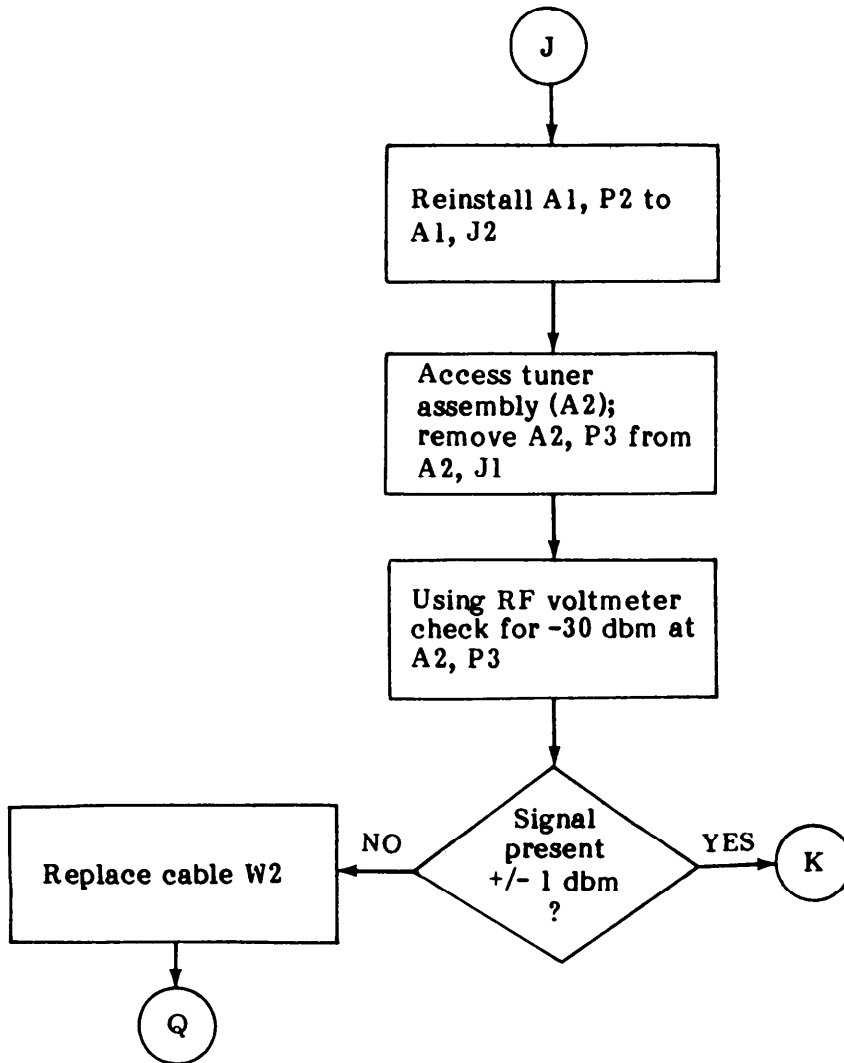
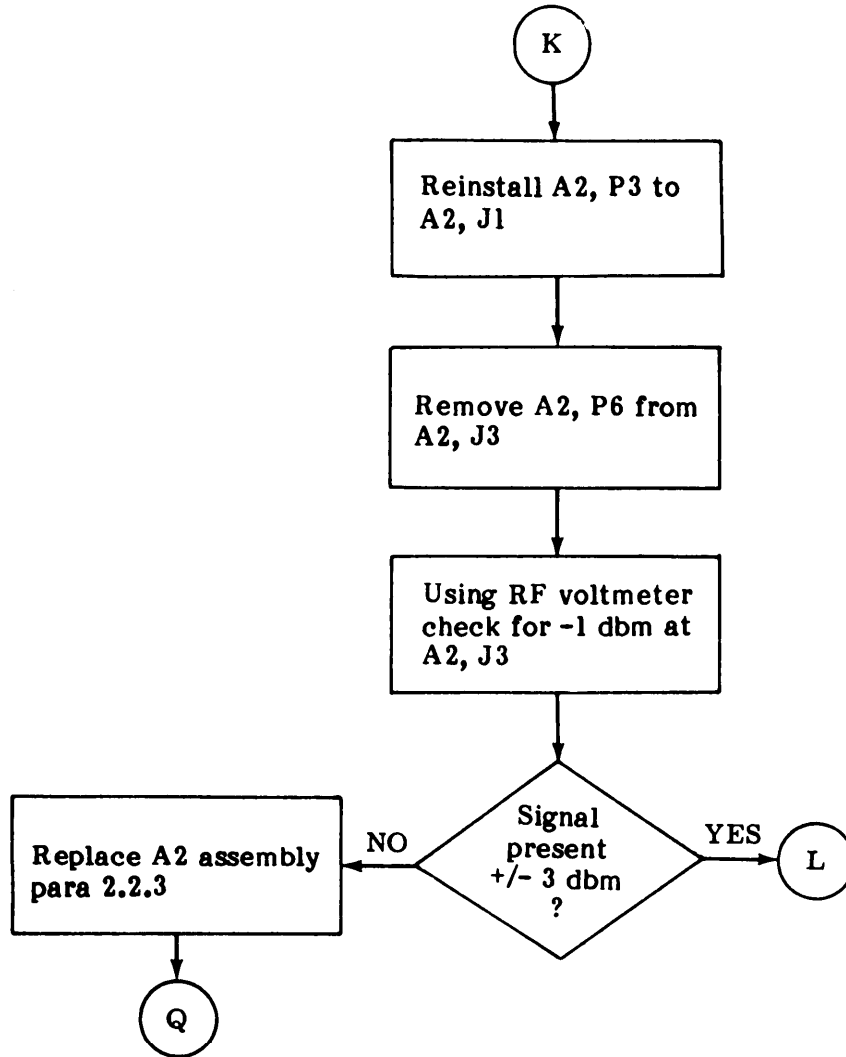


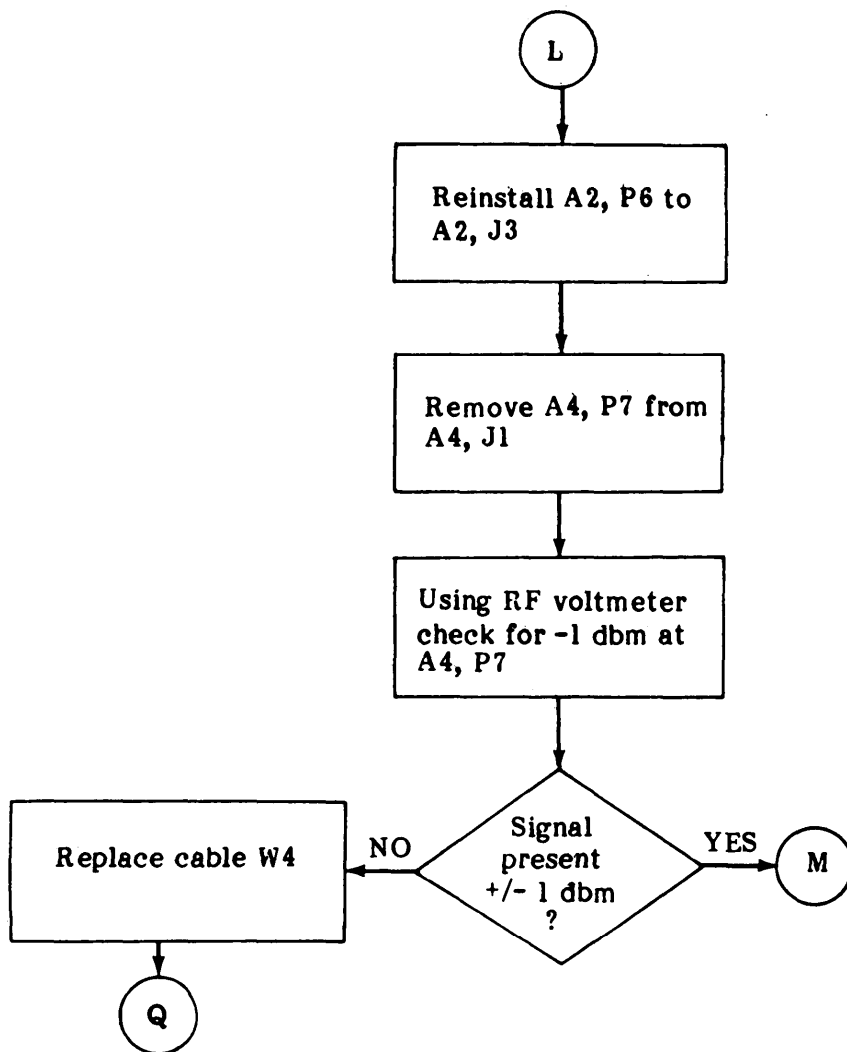
TABLE 4-1

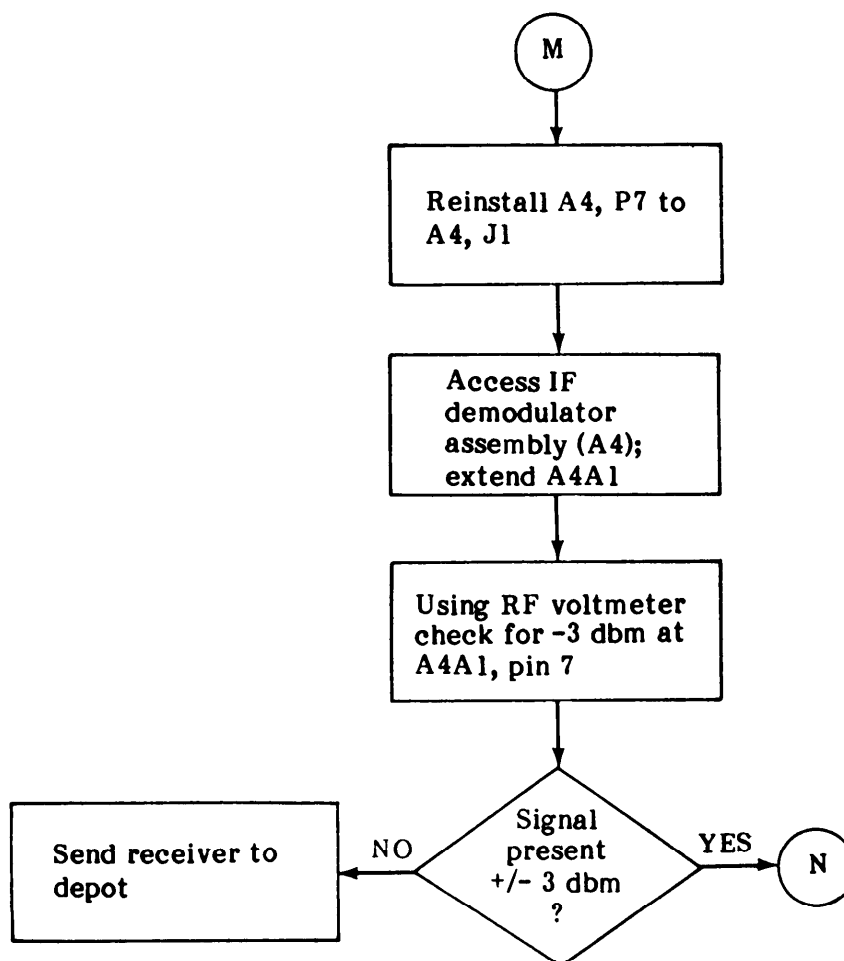


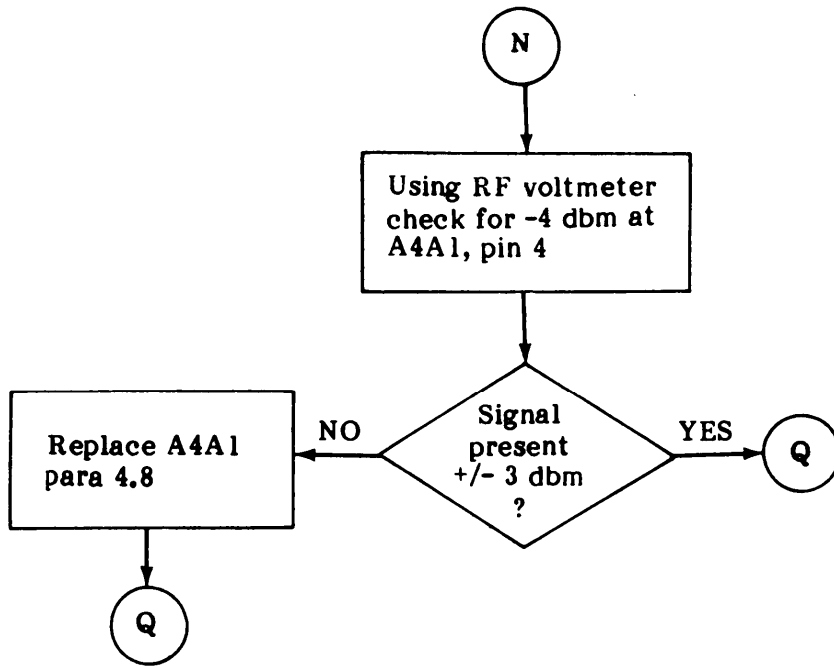


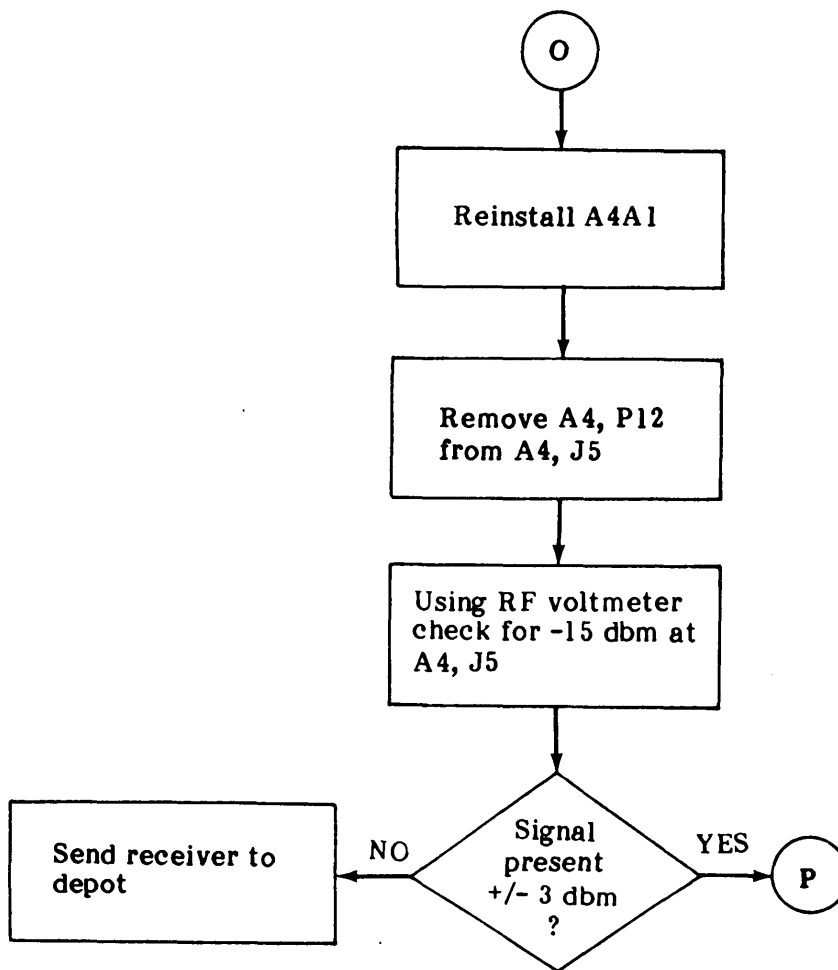


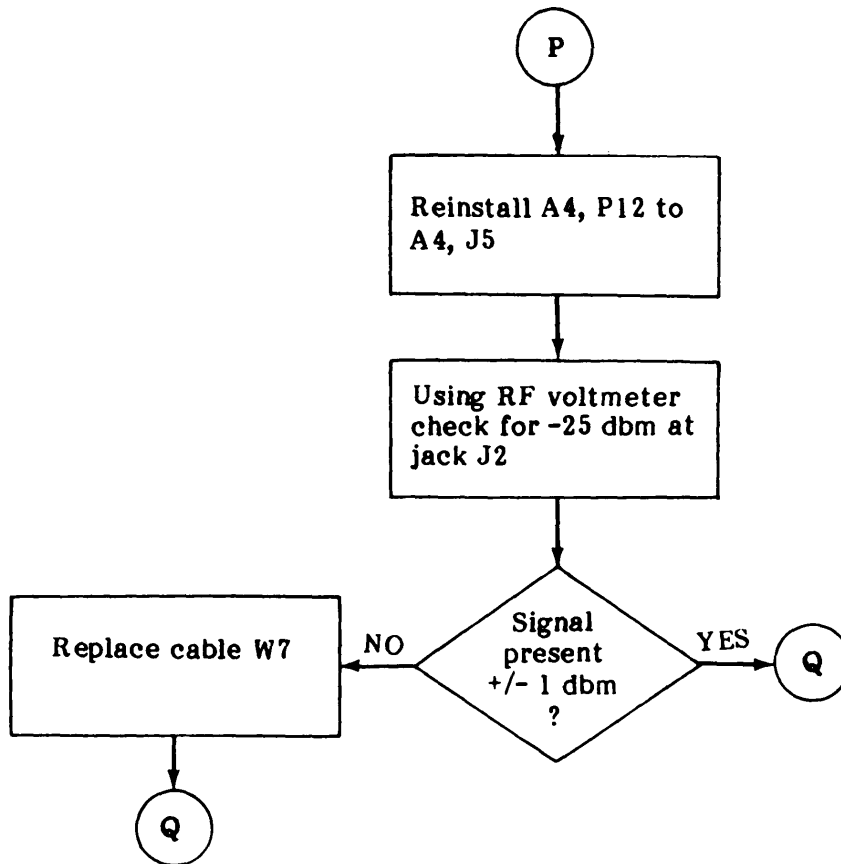


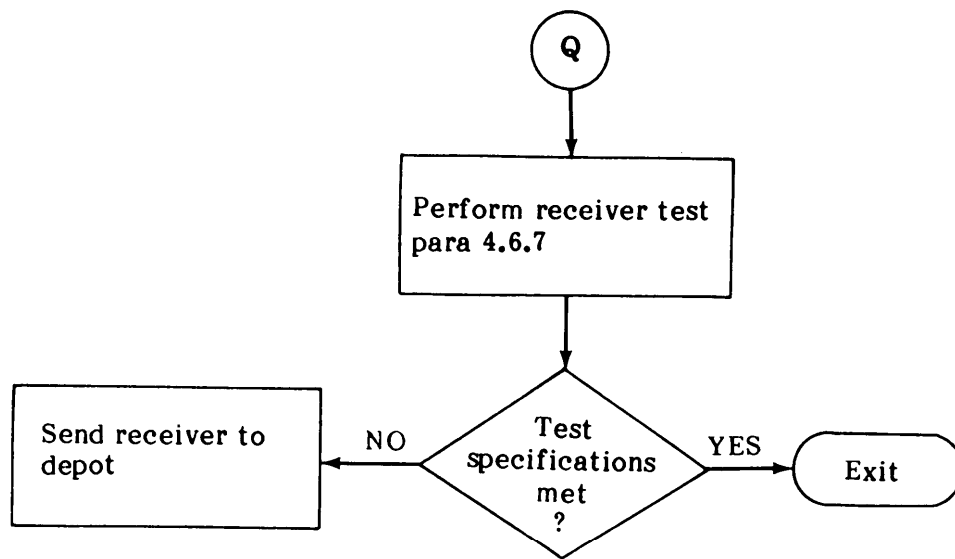












Courtesy of <http://BlackRadios.terryo.org>

NO AUDIO AND NO SIGNAL INDICATION ON SIGNAL STR METER IN ONE OR TWO IF BANDWIDTH (kHz) POSITIONS

INITIAL SETUPTest Equipment

| | |
|---------------------------------|--|
| Multimeter | AN/PSM-45 |
| Test Lead Set | Simpson 00577 |
| Signal Generator | SG-1112(V) I/U w/options 001, 002 and 003 |
| Cable, RF, 50 ohms, 4', BNC-BNC | HP 10503A |
| RF Voltmeter | Boonton 92C |
| High Frequency Probe | Boonton 91-12F |
| 50 ohm Adapter | Boonton 91-8B |
| Power Supply | PP-6547/U |

Tools

| | |
|----------------------------|------------------|
| No. 1 Phillips Screwdriver | 5120-00-240-8716 |
|----------------------------|------------------|

Replacement Parts

| | |
|--------------------------------------|----------|
| Gain BW Compensation Amp (A4A3) | 791802 |
| IF Filters and Diode Switches (A4A4) | 791803-1 |

Equipment Condition

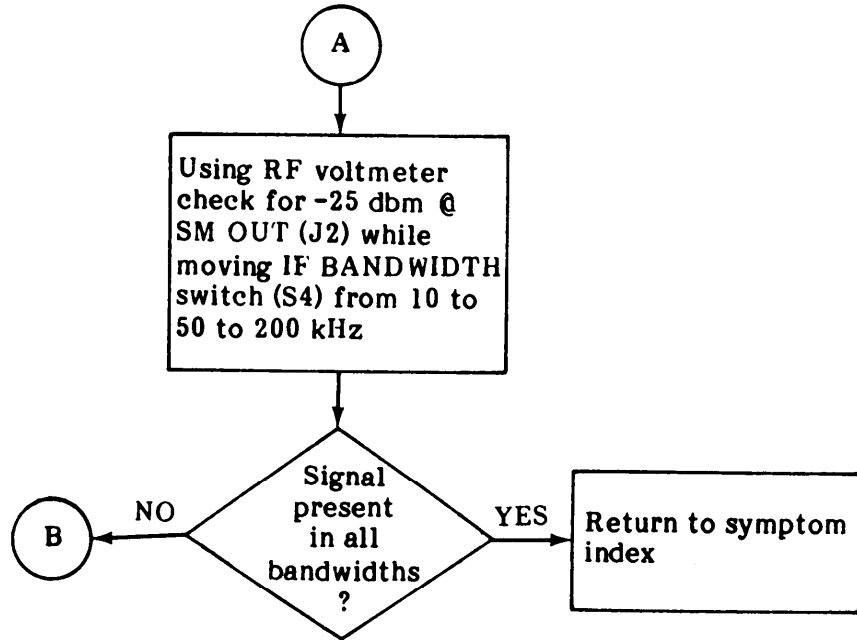
POWER switch (S7) set to ON
 BAND (MHz) switch (S8) set to HIGH BAND
 Receiver tuned to 150 MHz
 NODE switch (S5) set to AM
 RF GAIN (R5) fully clockwise (not in AGC)
 VOLUME control (R10) set to mid-range
 IF BANDWIDTH switch (S4) set to 10 KHz
 Front cover speaker connected to J4
 Receiver cover removed
 Signal generator set to 150 MHz CW @ -30 dbm
 Signal generator connected to RF IN (J 1)
 RF voltmeter referenced to signal generator and set to read -25 dbm
 RF voltmeter connected to SM OUTPUT (J2)
 Power supply set to 24 Vdc
 Power supply connected to J5
 WJ-9121 [TN-584/GRR(8)] Tuner installed

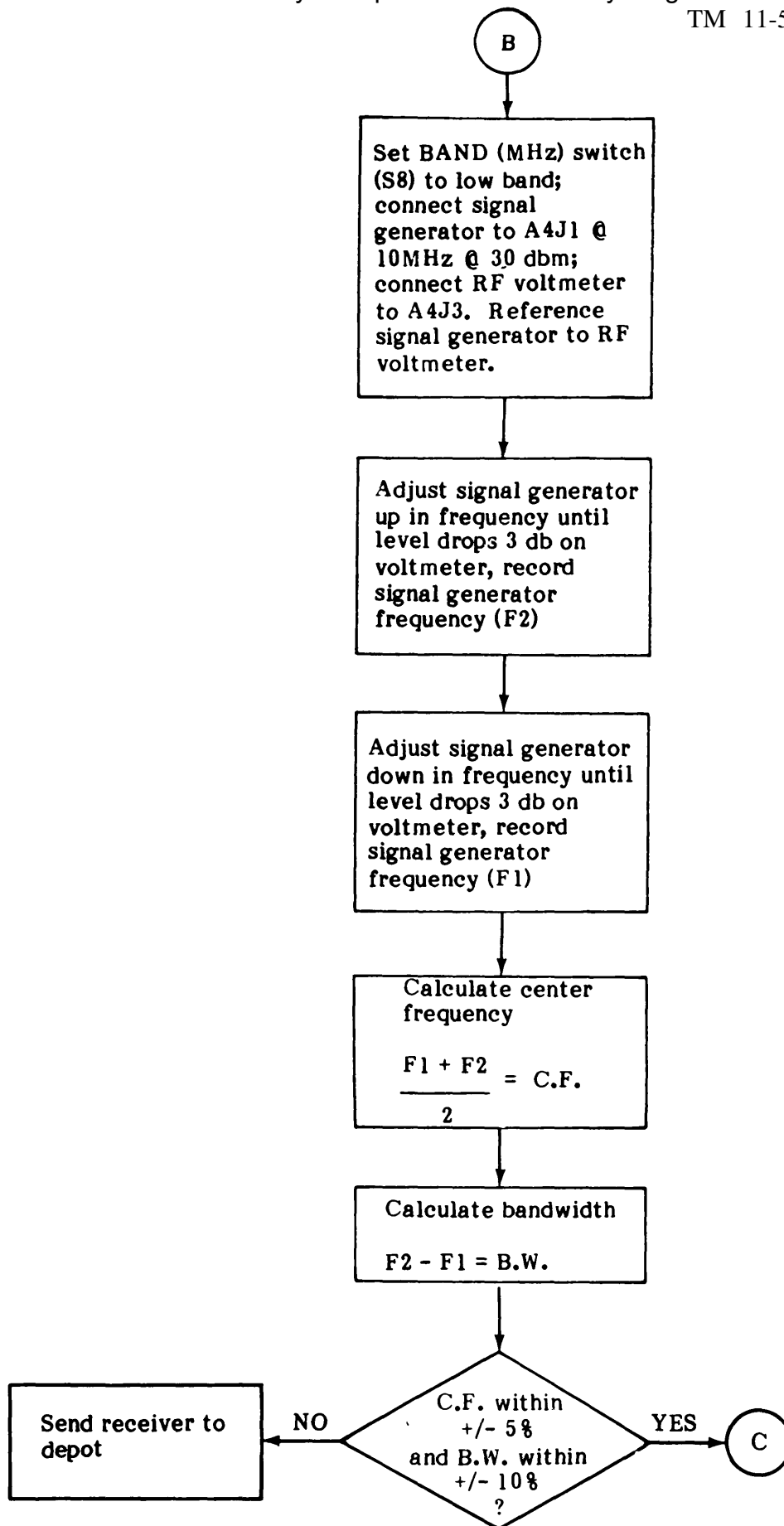
NOTE

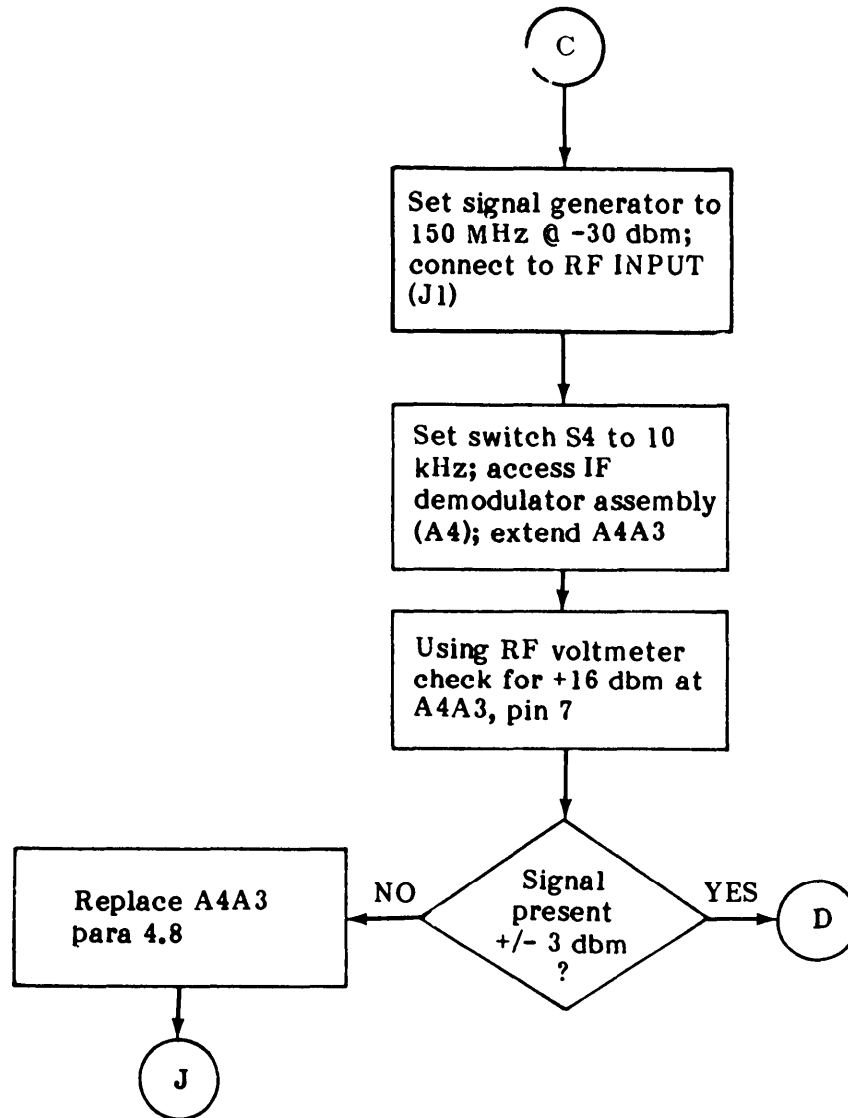
Level readings given reflect the use of the Boonton 91-8B 50 OHM adapter for all cable and connector measurements and the use of the Boonton 91-12F probe with tip at all circuit board measurements.

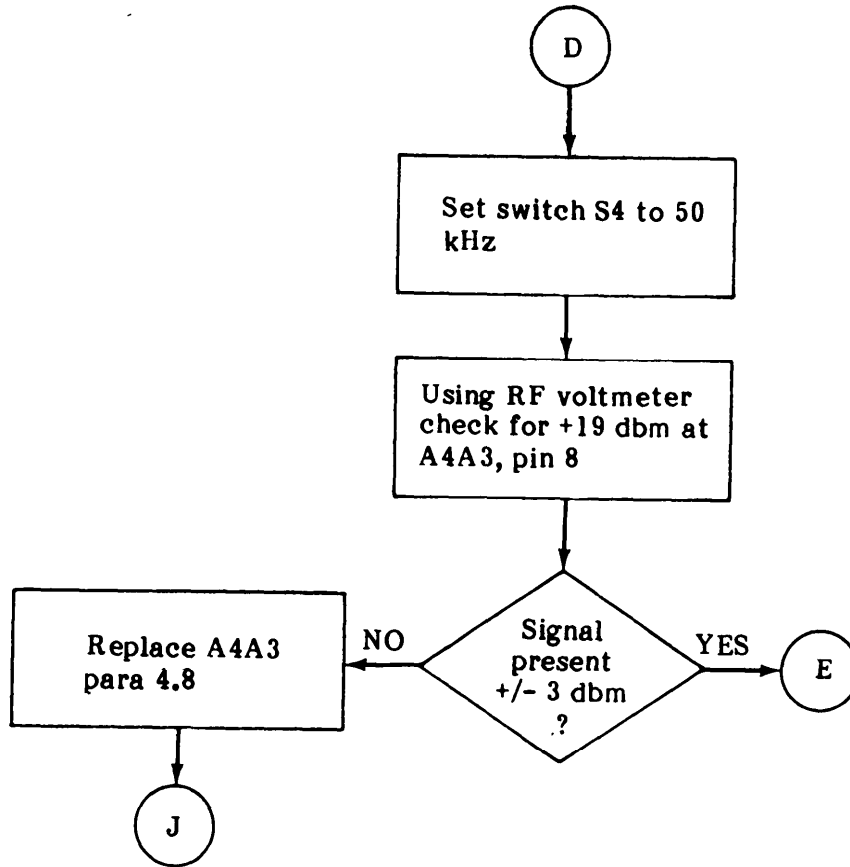
Minimum of 30 minutes warm-up time is required prior to starting troubleshooting procedures.

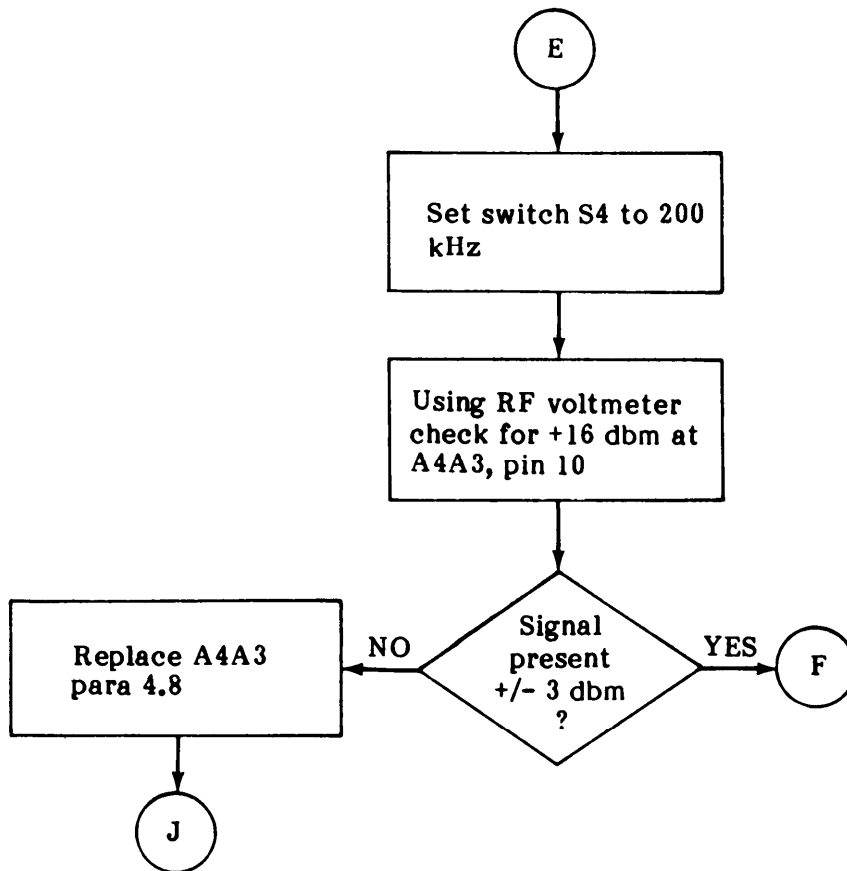
Courtesy of <http://BlackRadios.terryo.org>

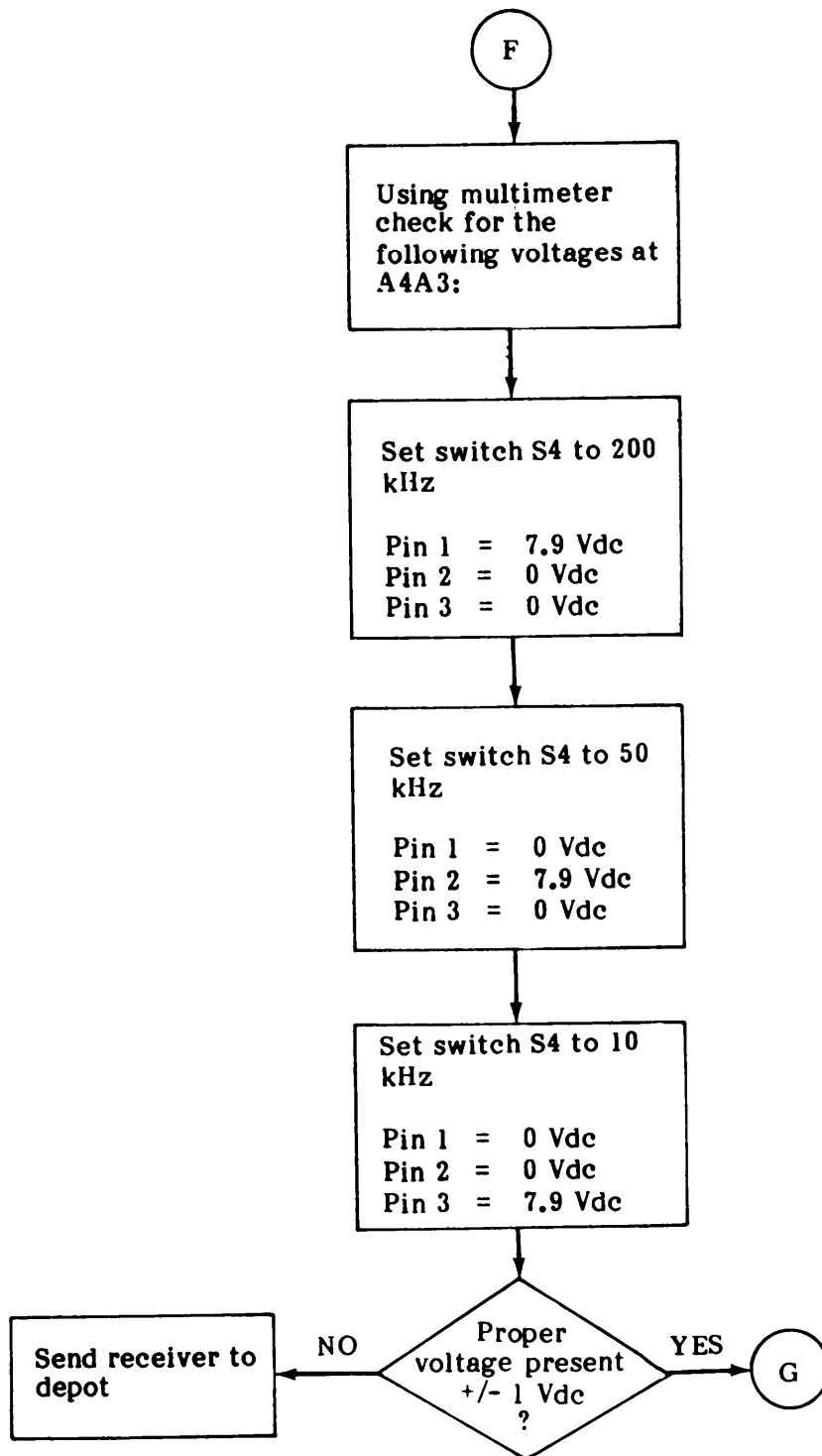












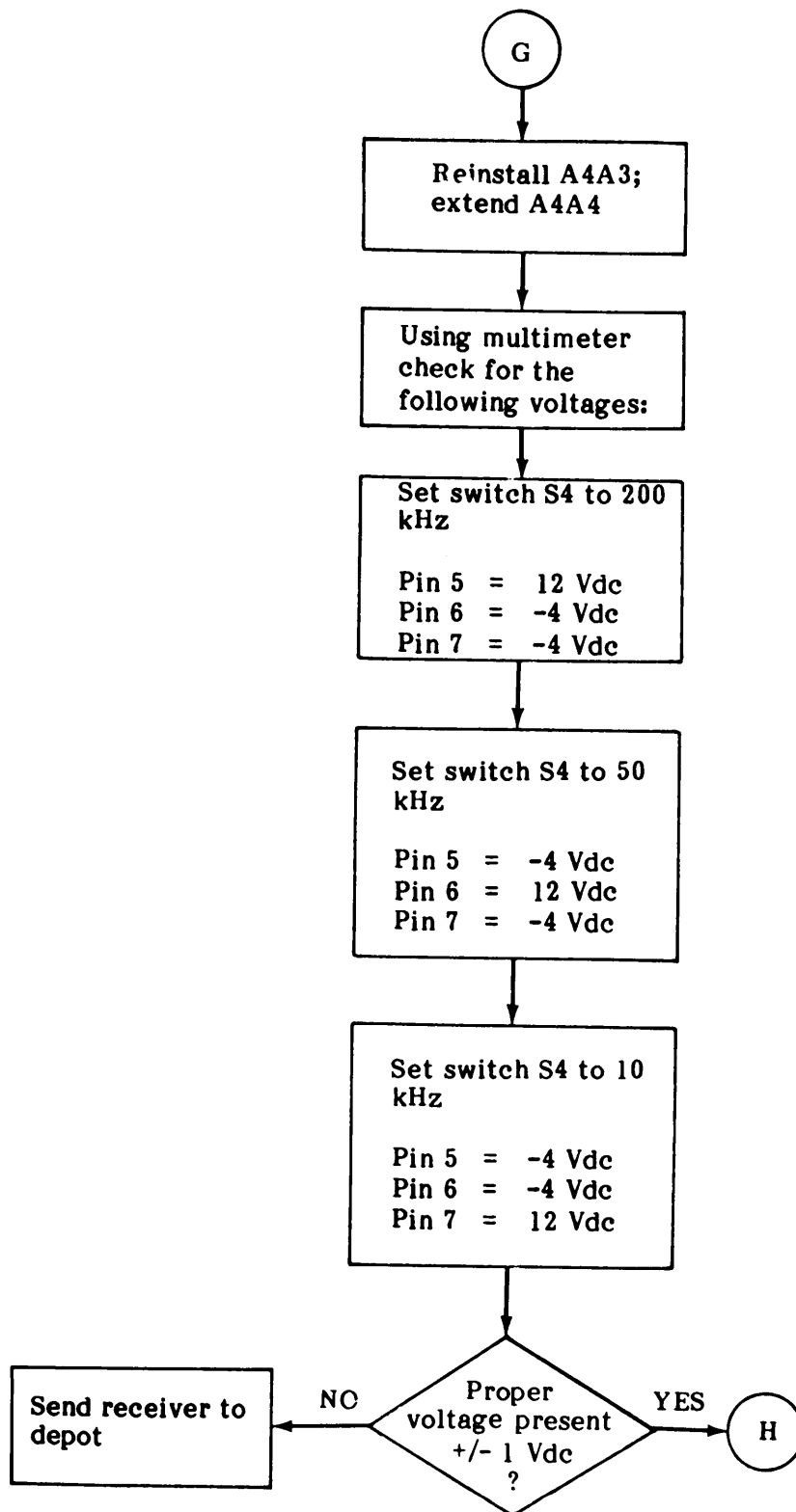
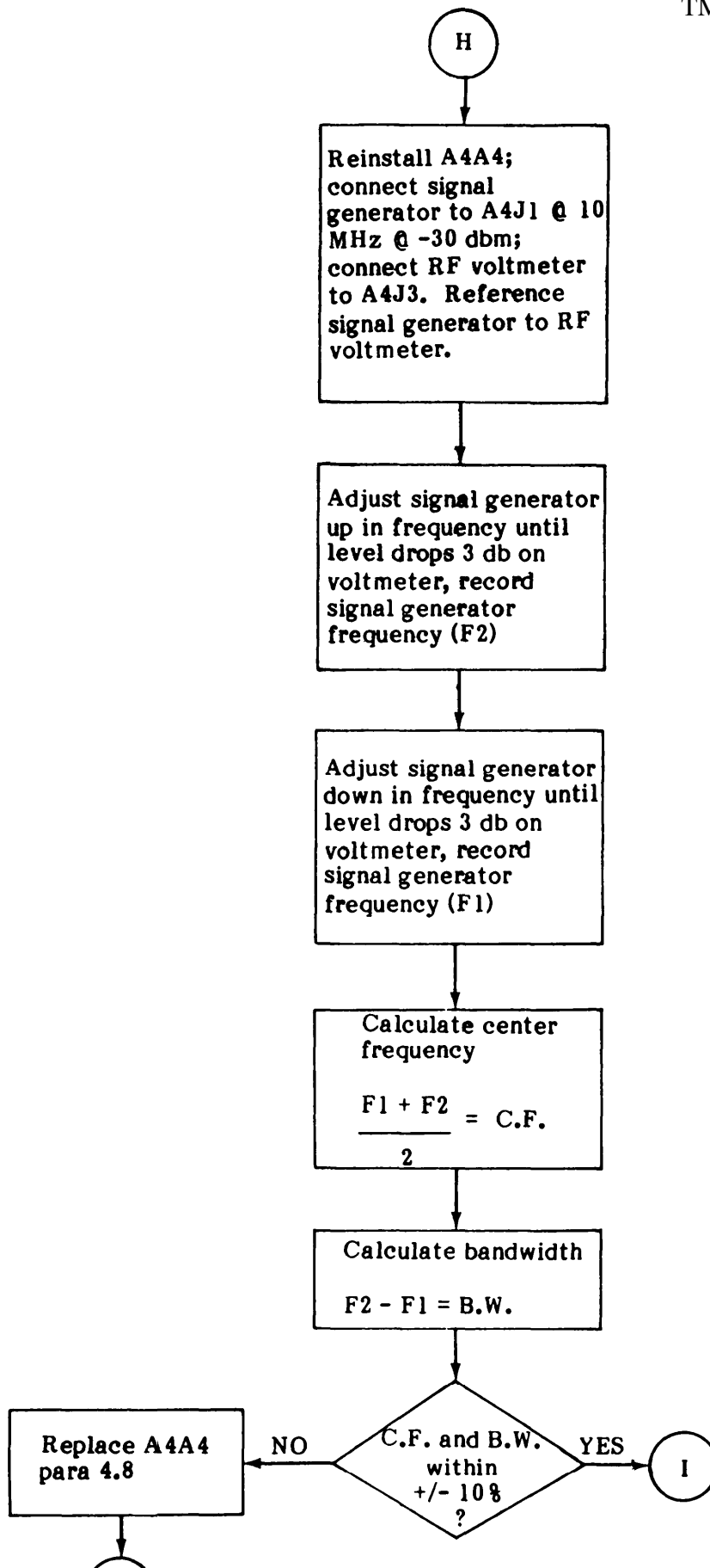
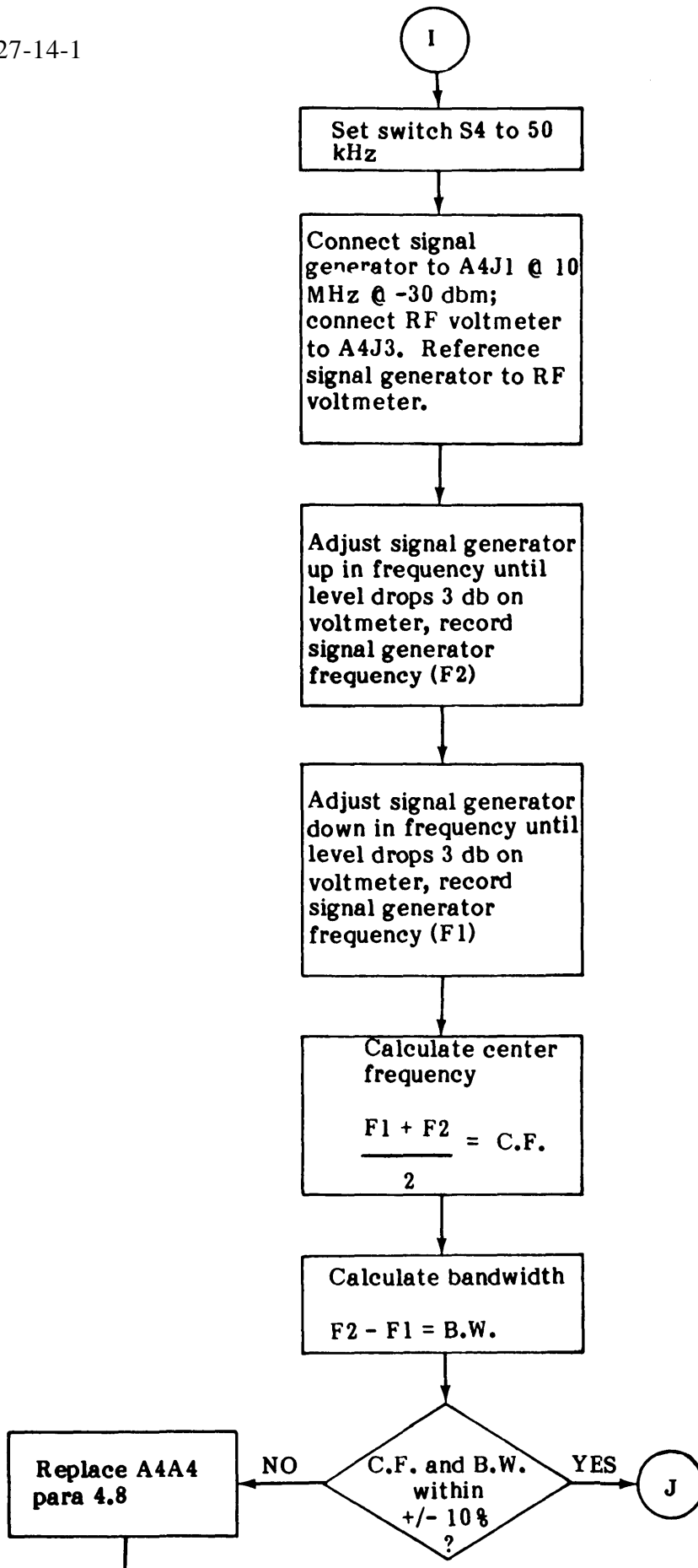
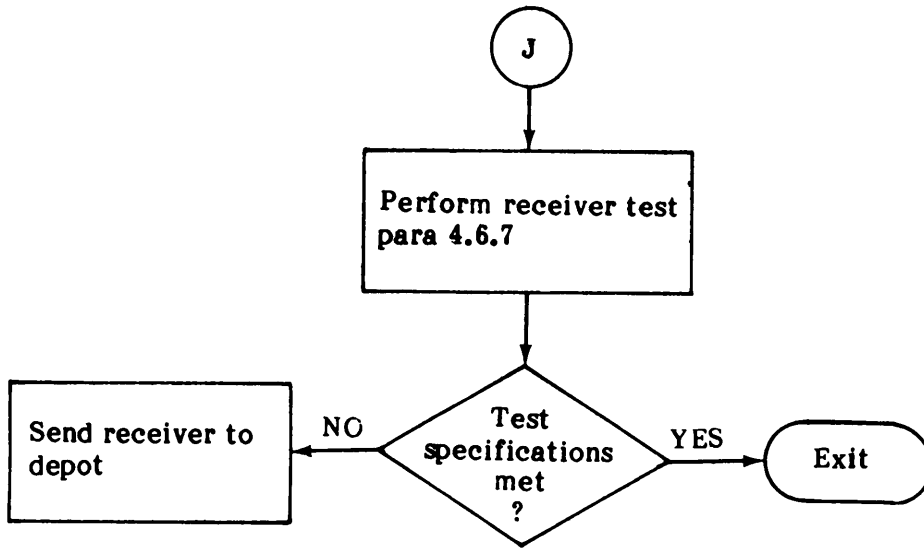


TABLE 4-1







NO AND NO SIGNAL INDICATION SIGNAL ON STR METER WHEN USB/CW OR LSB/CW IS SELECTED

INITIAL SETUP

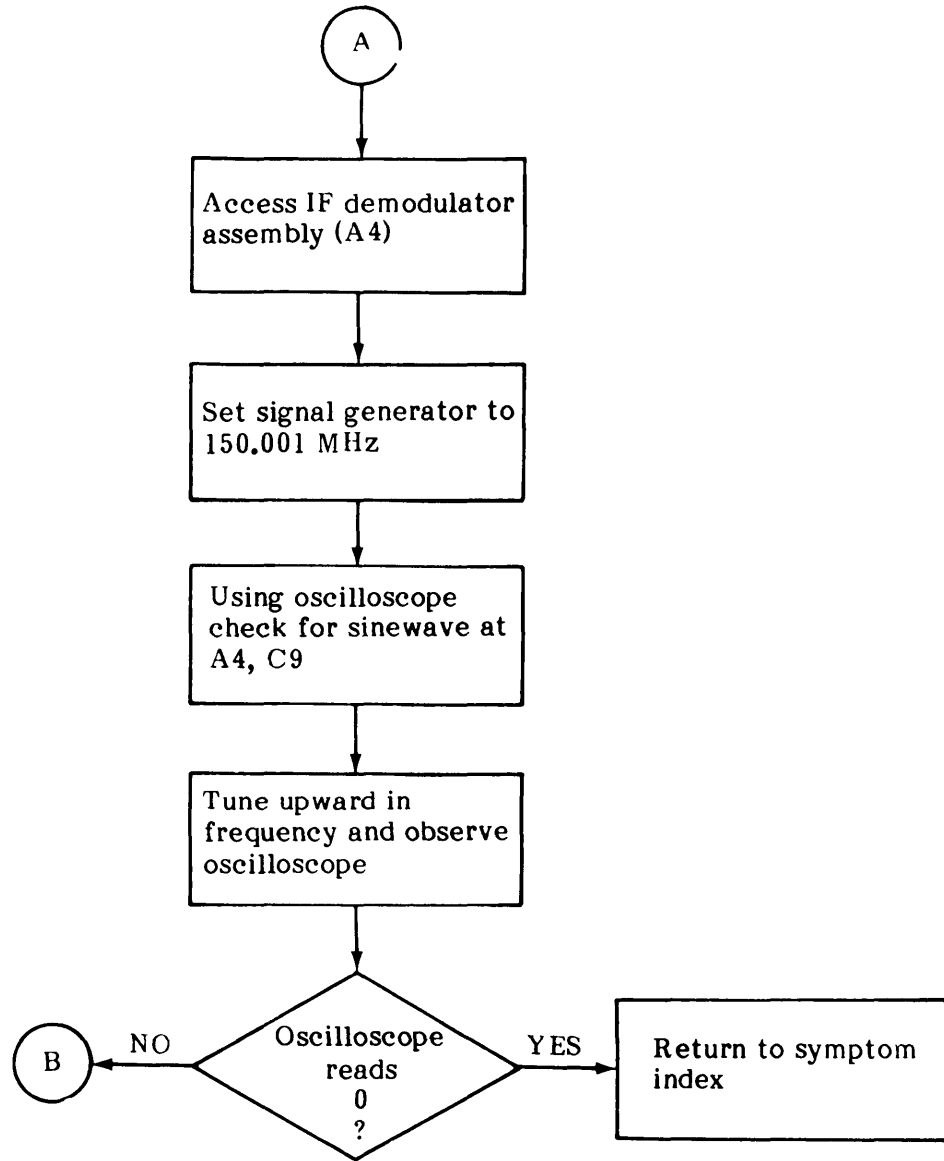
| | |
|---|---|
| <u>Test Equipment</u> | |
| Multimeter | AN/PSM-45 |
| Test Lead Set | Simpson 00577 |
| Signal Generator | SG-1112(V) 1/U w/options 001, 002 and 003 |
| Cable, RF, 50 ohms, 4', BNC-BNC | HP 10503A |
| RF Voltmeter | Boonton 92C |
| High Frequency Probe | Boonton 91-12F |
| Power Supply | PP-6547/U |
| Oscilloscope | AN/USM-281C |
| Voltage Probe, 10X | TEK P6006 |
| <u>Tools</u> | |
| 4 Inch Flat Tip Screwdriver | 5120-00-222-8852 |
| No. 1 Phillips Screwdriver | 5120-00-240-8716 |
| Card Extender | 791212 |
| <u>Replacement Parts</u> | |
| DC-DC Converter (A6) | 791794 |
| LSB/USB Filters (A4A9) | 791805 |
| Product Detector (A4A7) | 791785 |
| <u>Equipment Condition</u> | |
| POWER switch (S7) set to ON | |
| BAND (MHz) switch (S8) set to HIGH BAND | |
| Receiver tuned to 150 MHz | |
| MODE switch (S5) set to USB/CW | |
| RF GAIN (R5) fully clockwise (not in AGC) | |
| VOLUME control (R10) set to mid-range | |
| IF BANDWIDTH switch (S4) set to 10 KHz | |
| Front cover speaker connected to J4 | |
| Receiver cover removed | |
| Signal generator set to 150 MHz CW @ -30 dbm | |
| Signal generator connected to RF IN (J1) | |
| RF voltmeter referenced to signal generator and set to read -25 dbm | |
| RF voltmeter connected to SM OUTPUT (J2) | |
| Power supply set to 24 Vdc | |
| Power supply connected to J5 | |
| WJ-9121 [TN-584/GRR8(V)] Tuner installed | |

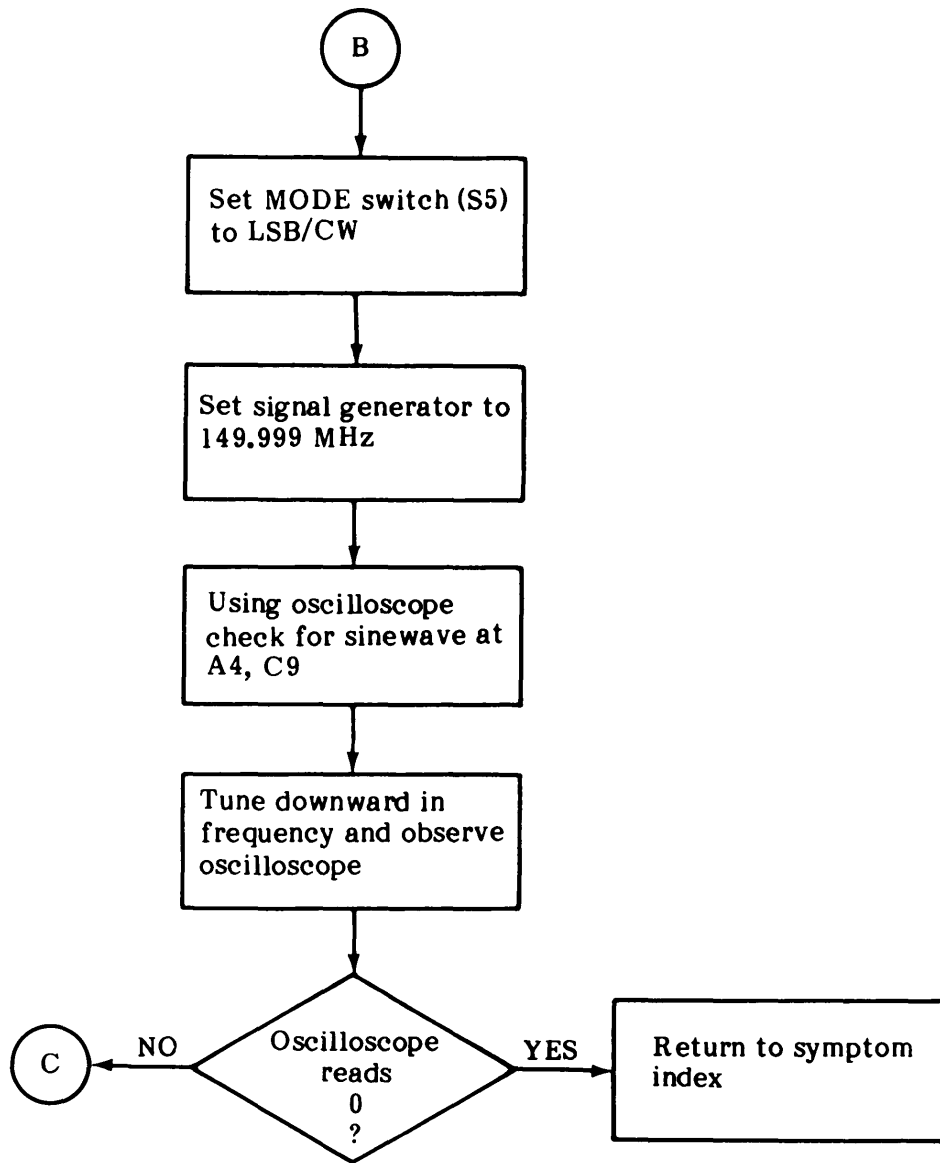
NOTE

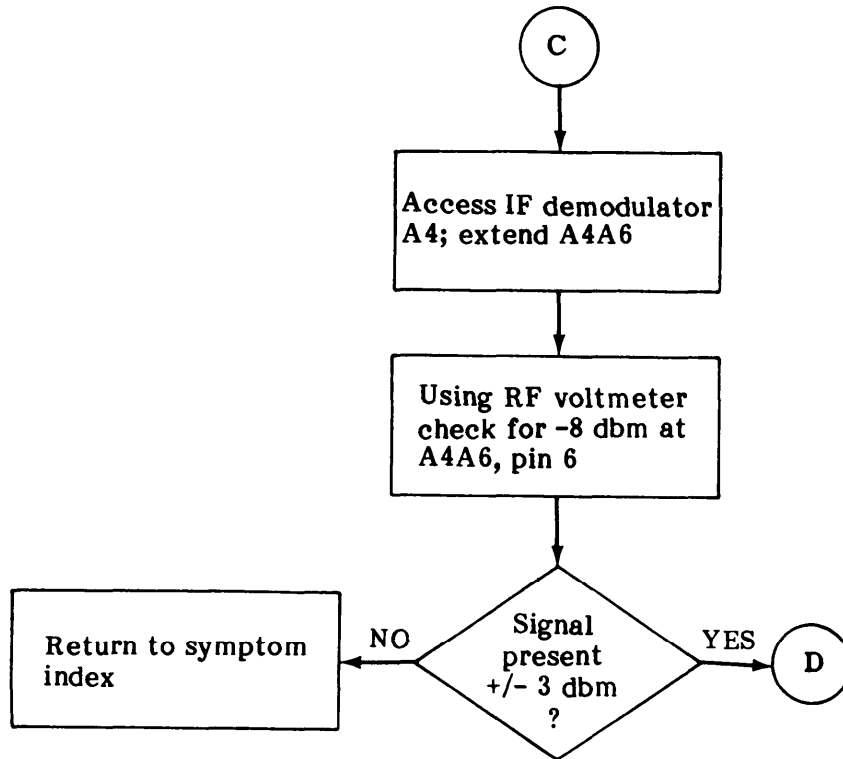
Level readings given reflect the use of the Boonton 91-8B 50 OHM adapter for all cable and connector measurements and the use of the Boonton 91-12F probe with tip at all circuit board measurements.

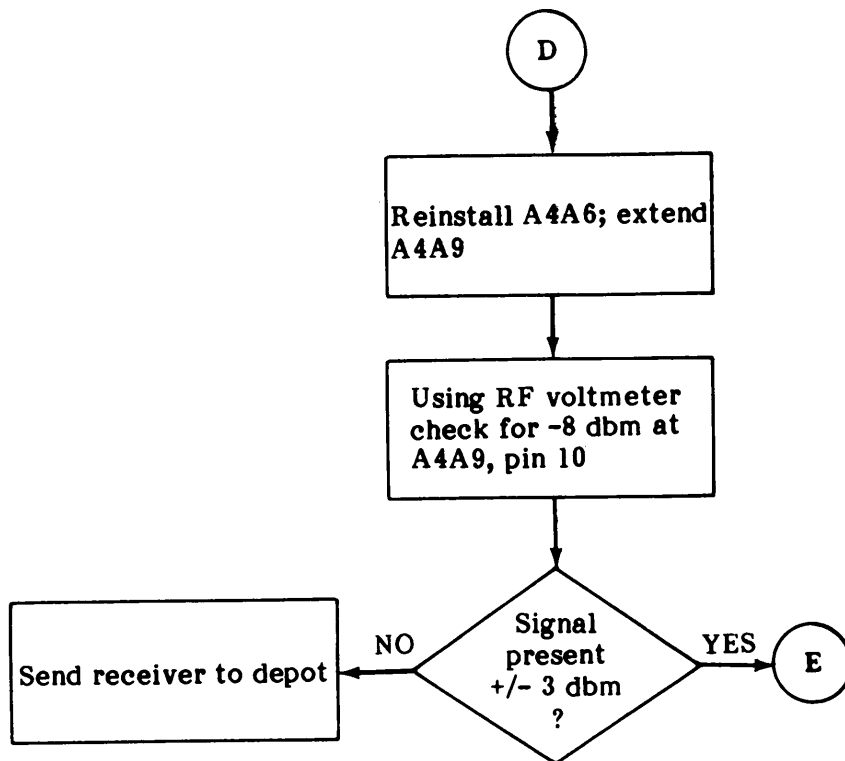
Minimum of 30 minutes warm-up time is required prior to starting troubleshooting procedures

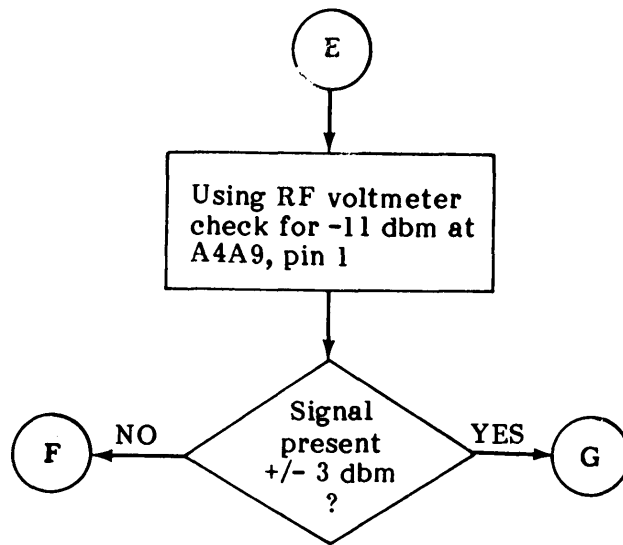
Courtesy of <http://BlackRadios.terryo.org>

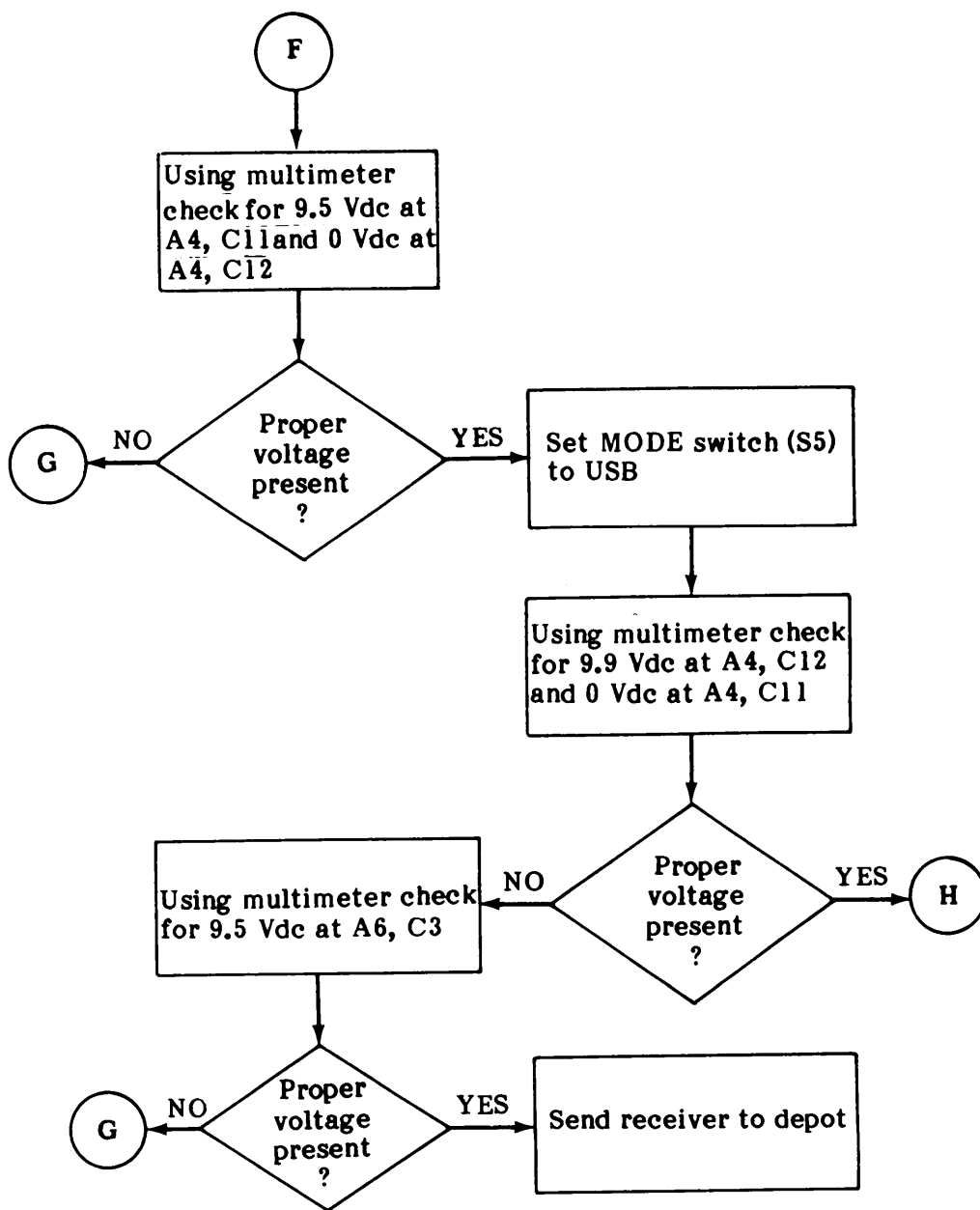


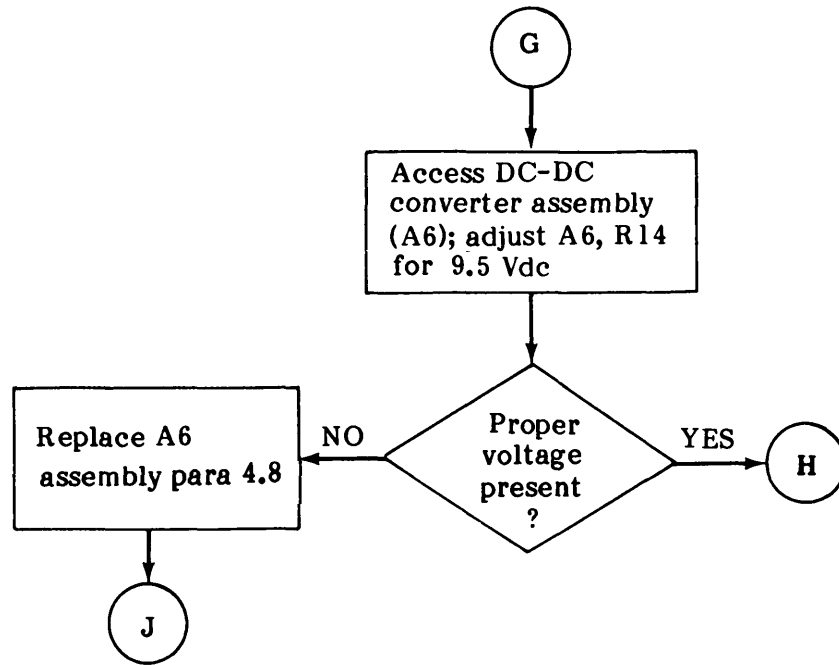


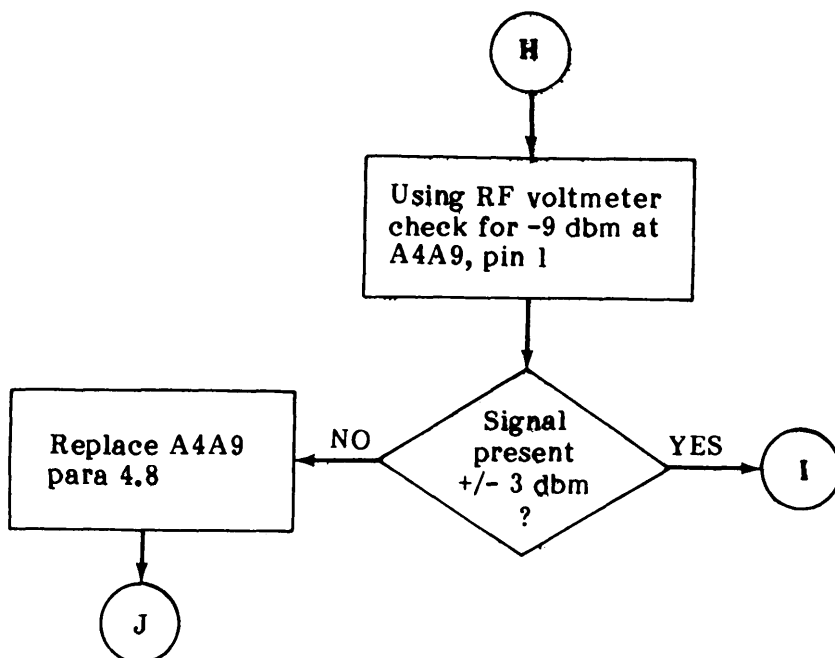


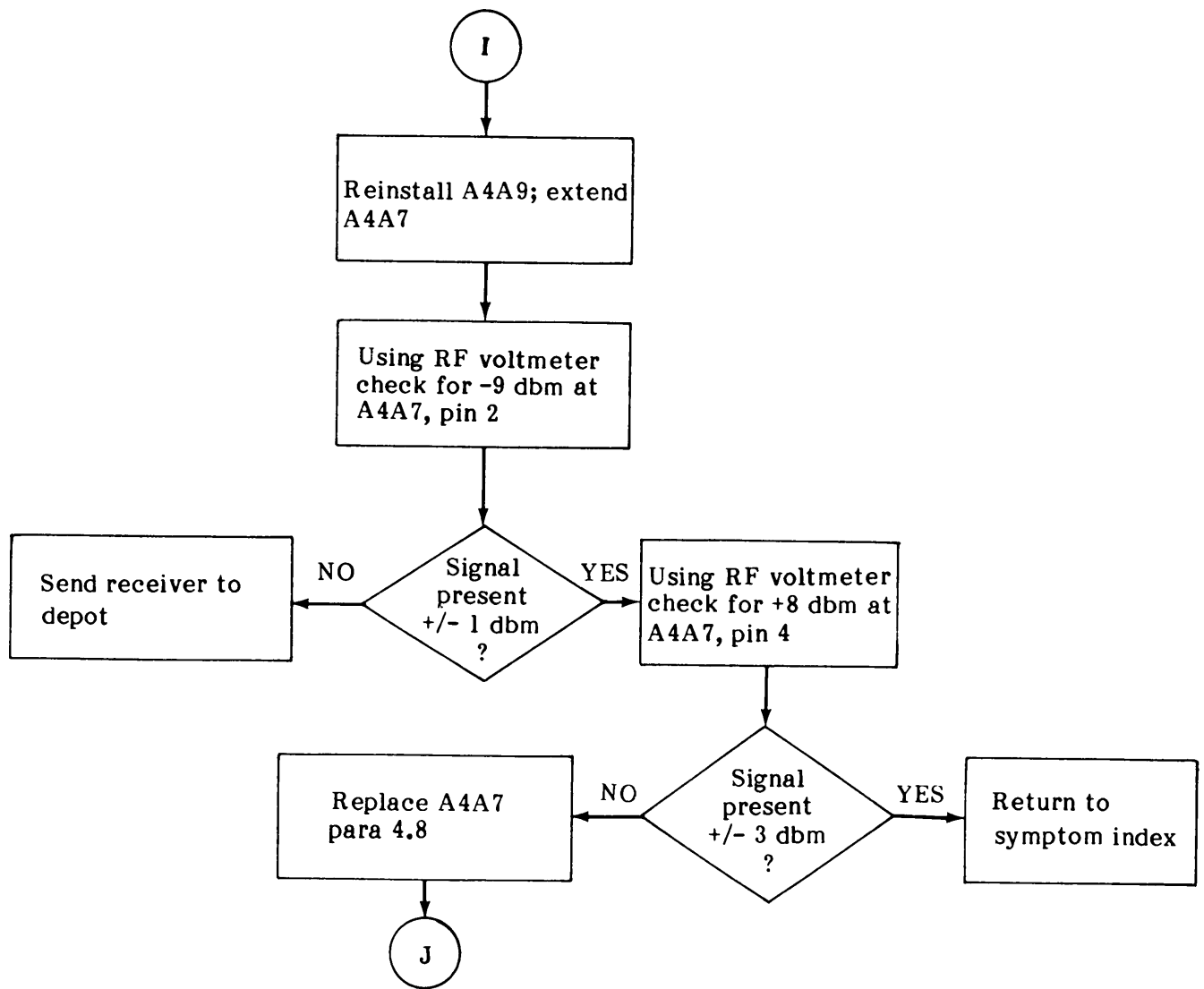


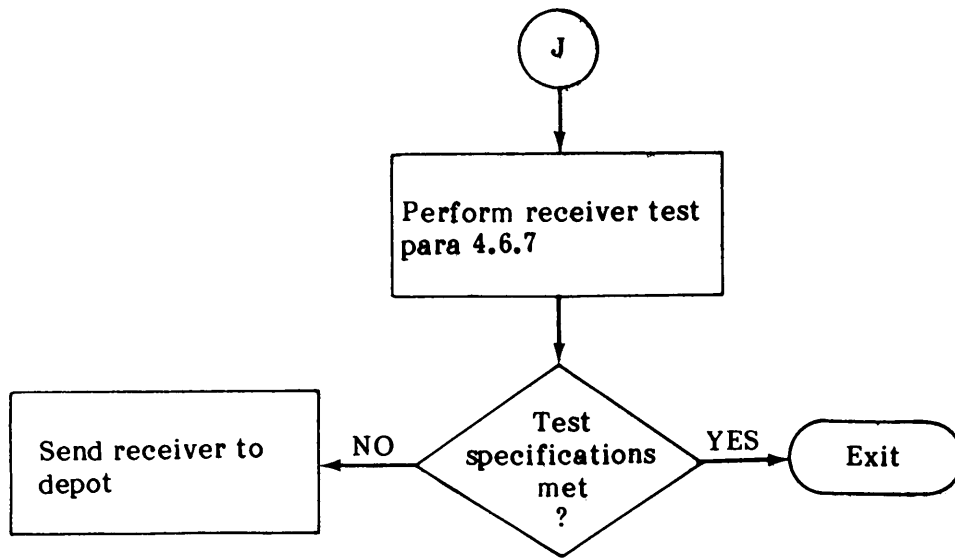












NO AUDIO AND NO SIGNAL INDICATION ON SIGNAL STR METER WHEN AM IS SELECTED

INITIAL SETUP

Test Equipment

| | |
|---------------------------------|---|
| Multimeter | AN/PSM-45 |
| Test Lead Set | Simpson 00577 |
| Signal Generator | SG-1112(V) 1/U w/options 001, 002 and 003 |
| Cable, RF, 50 ohms, 4', BNC-BNC | HP 10503A |
| RF Voltmeter | Boonton 92C |
| High Frequency Probe | Boonton 91-12F |
| Power Supply | PP-6547/U |

Tools

| | |
|-----------------------------|------------------|
| 4 Inch Flat Tip Screwdriver | 5120-00-222-8852 |
| No. 1 Phillips Screwdriver | 5120-00-240-8716 |
| Card Extender | 791212 |

Replacement Parts

| | |
|---------------------------|--------|
| AM Detector Buffer (A4A6) | 791790 |
| DC-DC Converter (A6) | 791794 |

Equipment Condition

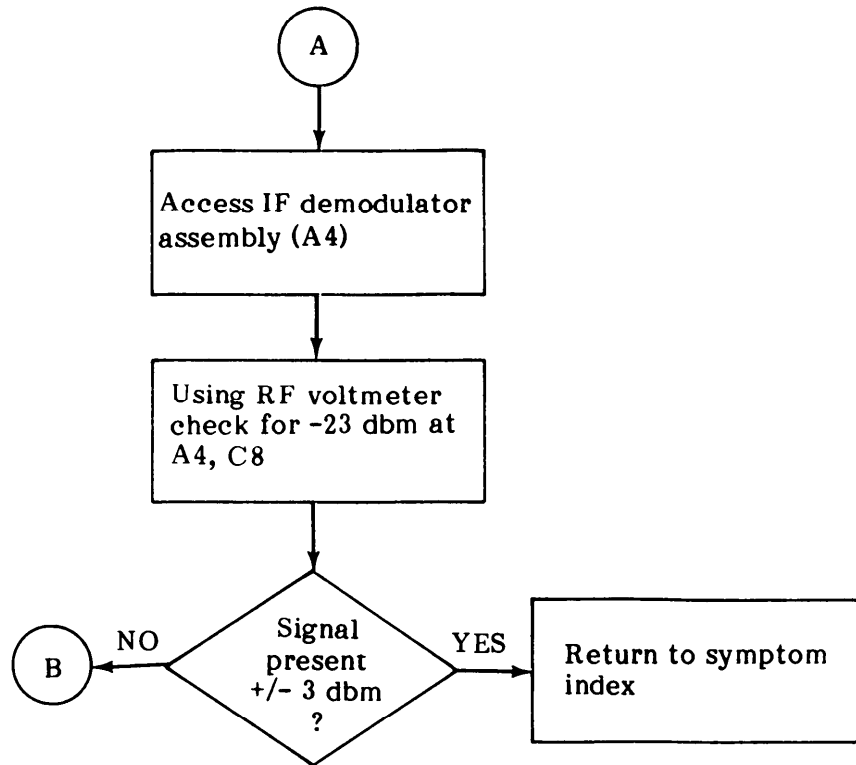
POWER switch (S7) set to ON
 BAND (MHz) switch (S8) set to HIGH BAND
 Receiver tuned to 150 MHz
 MODE switch (S5) set to AM
 RF GAIN (R5) fully clockwise (not in AGC)
 VOLUME control (R10) set to mid-range
 IF BANDWIDTH switch (S4) set to 10 KHz
 Front cover speaker connected to J4
 Receiver cover removed
 Signal generator set to 150 MHz @ -30 dbm AM 400 Hz 50%
 Signal generator connected to RF IN (J1)
 RF voltmeter referenced to signal generator and set to read -25 dbm
 RF voltmeter connected to SM OUTPUT (J2)
 Power supply set to 24 Vdc
 Power supply connected to J5
 WN-9121 [TN-584/GRR8(V)] Tuner installed

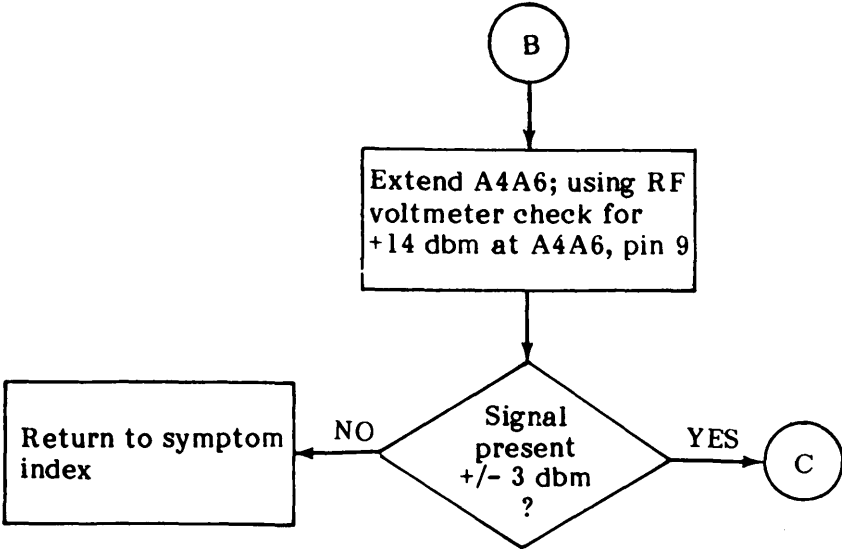
NOTE

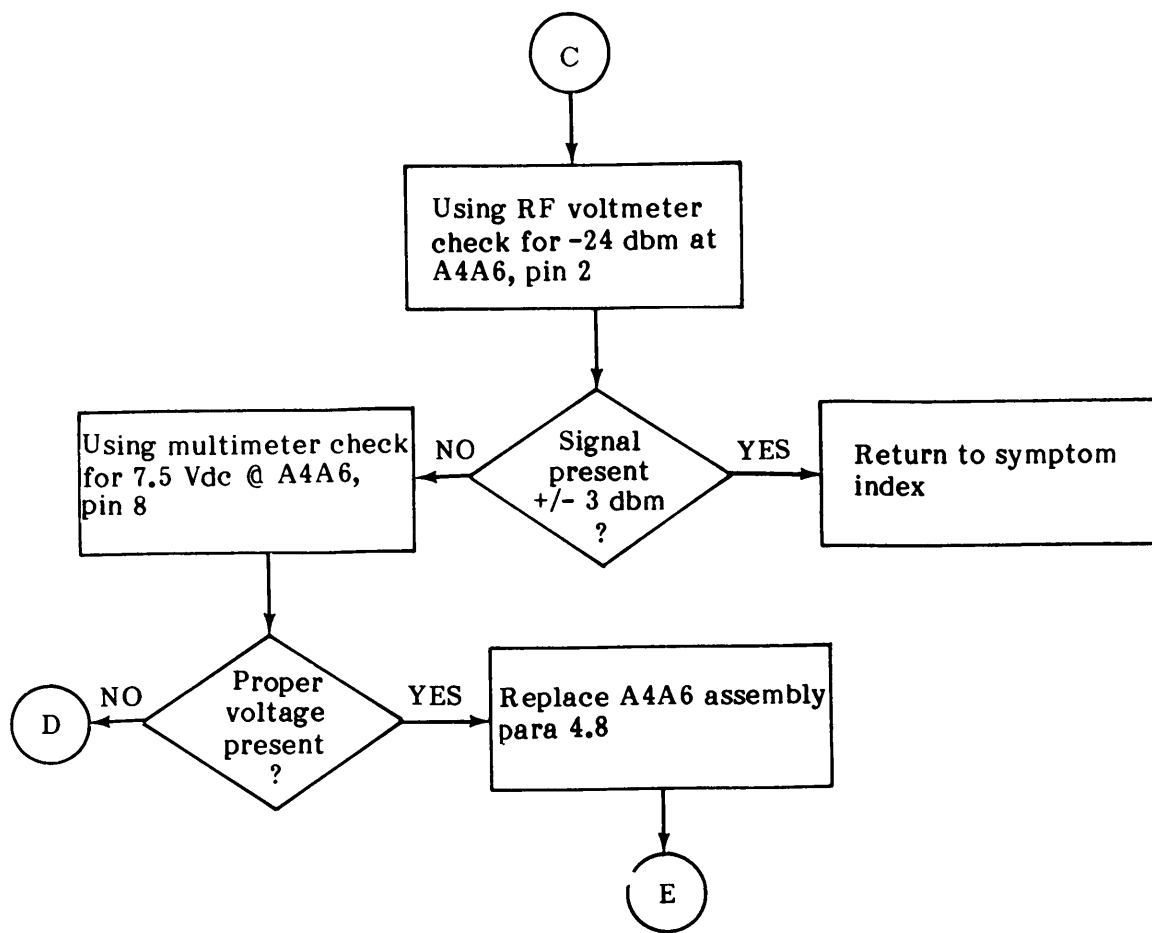
Level readings given reflect the use of the Boonton 91-8B 50 OHM adapter for all cable and connector measurements and the use of the Boonton 91-12F probe with tip at all circuit board measurements

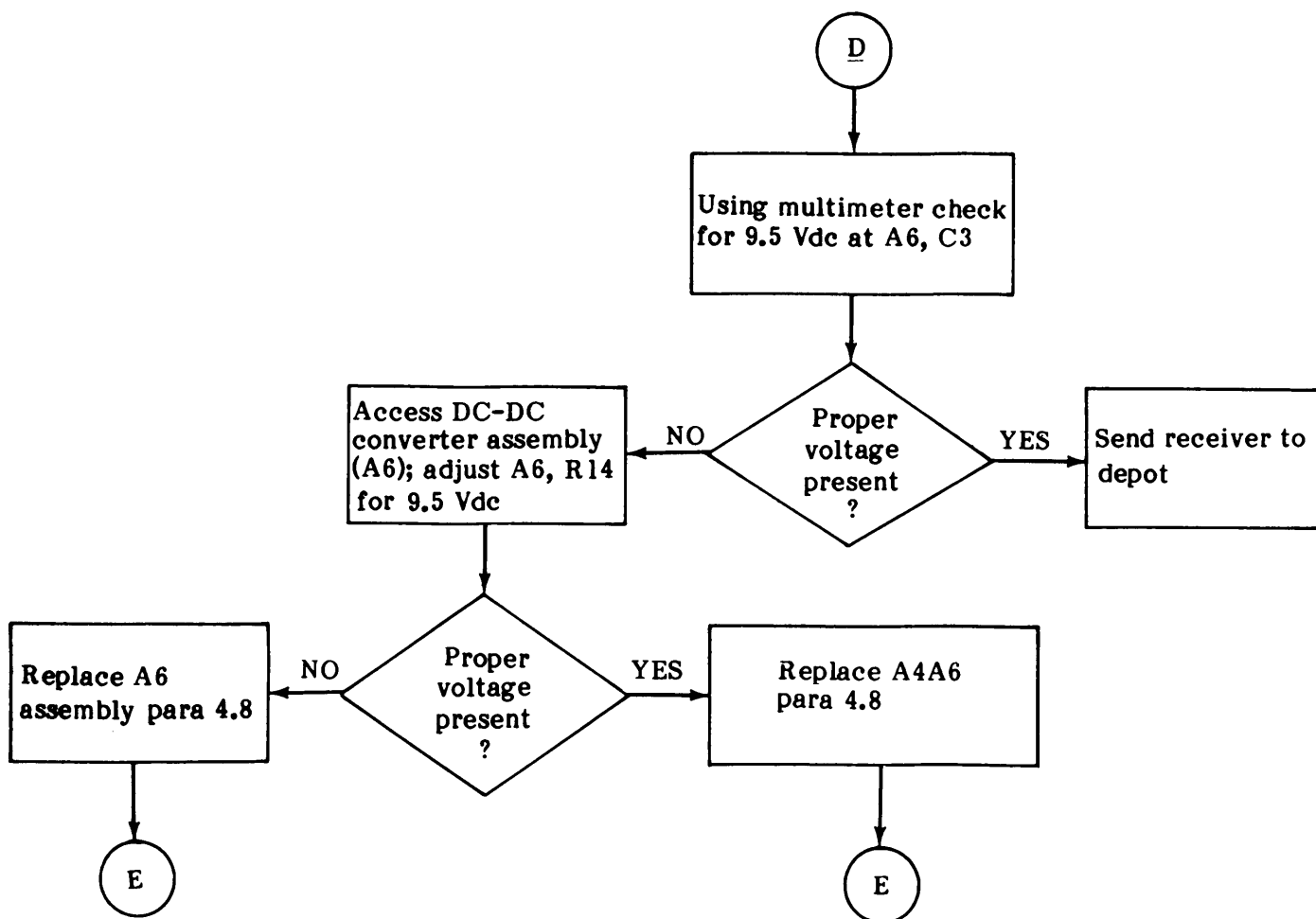
Minimum of 30 minutes warm-up time is required prior to starting troubleshooting procedures,

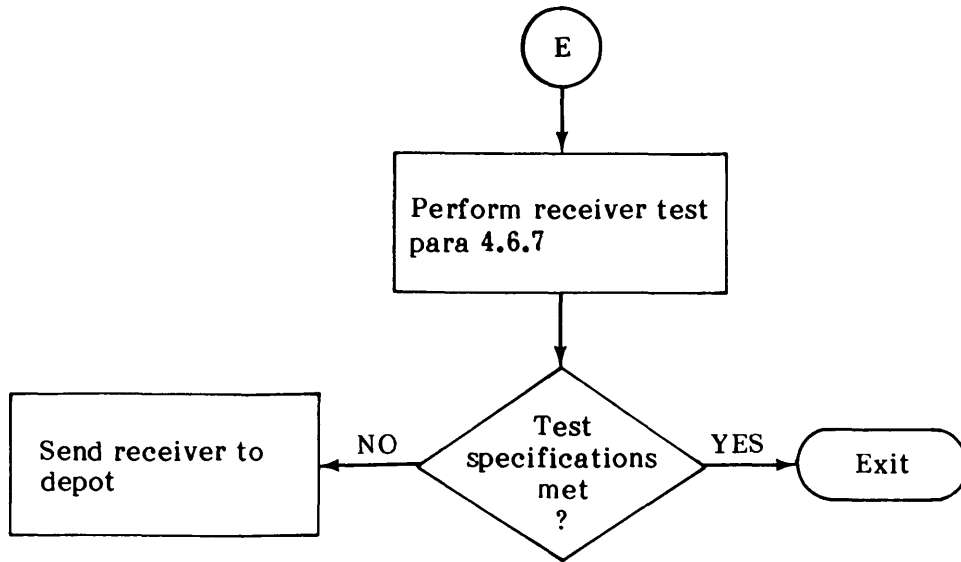
Courtesy of <http://BlackRadios.terryo.org>











Courtesy of <http://BlackRadios.terryo.org>

NO AUDIO AND NO SIGNAL INDICATION ON SIGNAL STR METER WHEN FM IS SELECTED

INITIAL SETUP

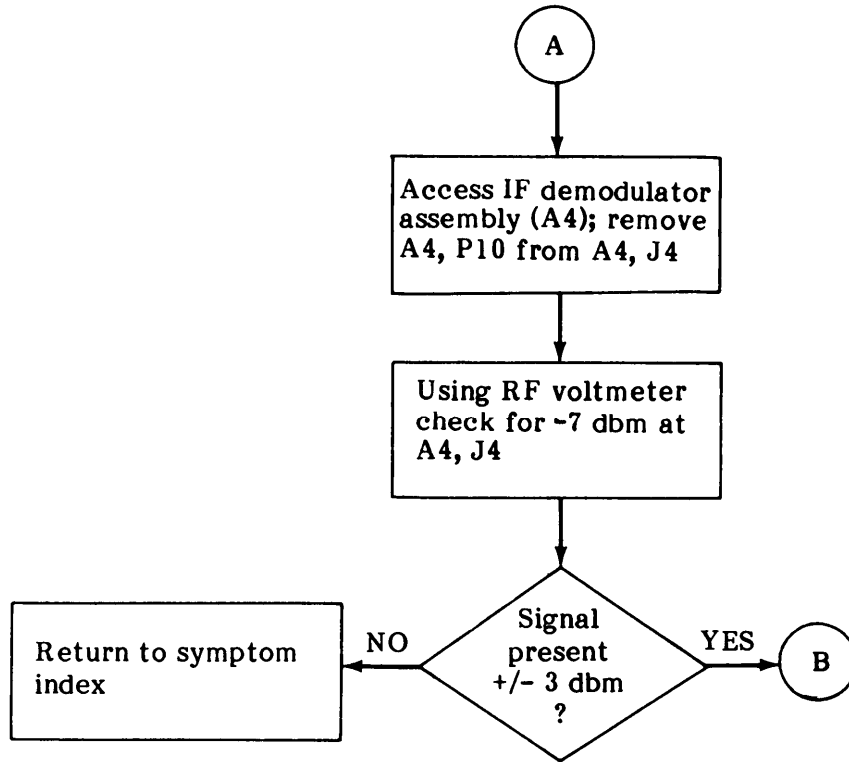
| | |
|---|---|
| <u>Test Equipment</u> | |
| Multimeter | AN/PSM-45 |
| Test Lead Set | Simpson 00577 |
| Signal Generator | SG-1112(V) 1/U w/options 001, 002 and 003 |
| Cable, RF, 50 ohms, 4', BNC-BNC | HP 10503A |
| RF Voltmeter | Boonton 92C |
| High Frequency Probe | Boonton 91-12F |
| 50 ohm Adapter | Boonton 91-8B |
| Power Supply | PP-6547/U |
| oscilloscope | AN/USM-281C |
| Voltage Probe, 10X | TEK P6006 |
| <u>Tools</u> | |
| 4 Inch Flat Tip Screwdriver | 5120-00-222-8852 |
| No. 1 Phillips Screwdriver | 5120-00-240-8716 |
| Card Extender | 791212 |
| <u>Replacement Parts</u> | |
| AM Detector Buffer (A4A6) | 791790 |
| DC-DC Converter (A6) | 791794 |
| Cable (W6) | 17300-148-6 |
| <u>Equipment Condition</u> | |
| POWER switch (S7) set to ON | |
| BAND (MHz) switch (S8) set to HIGH BAND | |
| Receiver tuned to 150 MHz | |
| MODE switch (S5) set to FM | |
| RF GAIN (R5) fully clockwise (not in AGC) | |
| VOLUME control (R10) set to mid-range | |
| IF BANDWIDTH switch (S4) set to 10 KHz | |
| Front cover speaker connected to J4 | |
| Receiver cover removed | |
| Signal generator set to 150 MHz @ -30 dbm AM 400 Hz 50% | |
| Signal generator connected to RF IN (J1) | |
| RF voltmeter referenced to signal generator and set to read -25 dbm | |
| RF voltmeter connected to SM OUTPUT (J2) | |
| Power supply set to 24 Vdc | |
| power supply connected to J5 | |
| WJ-9121 [TN-584/GRR8(V)] Tuner installed | |

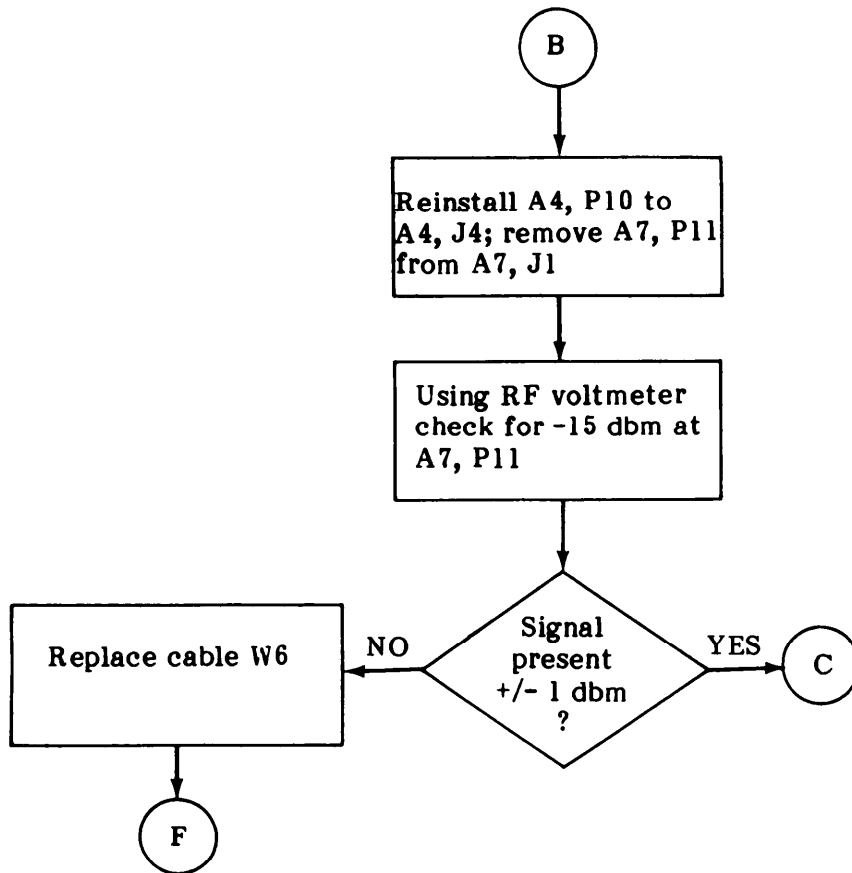
NOTE

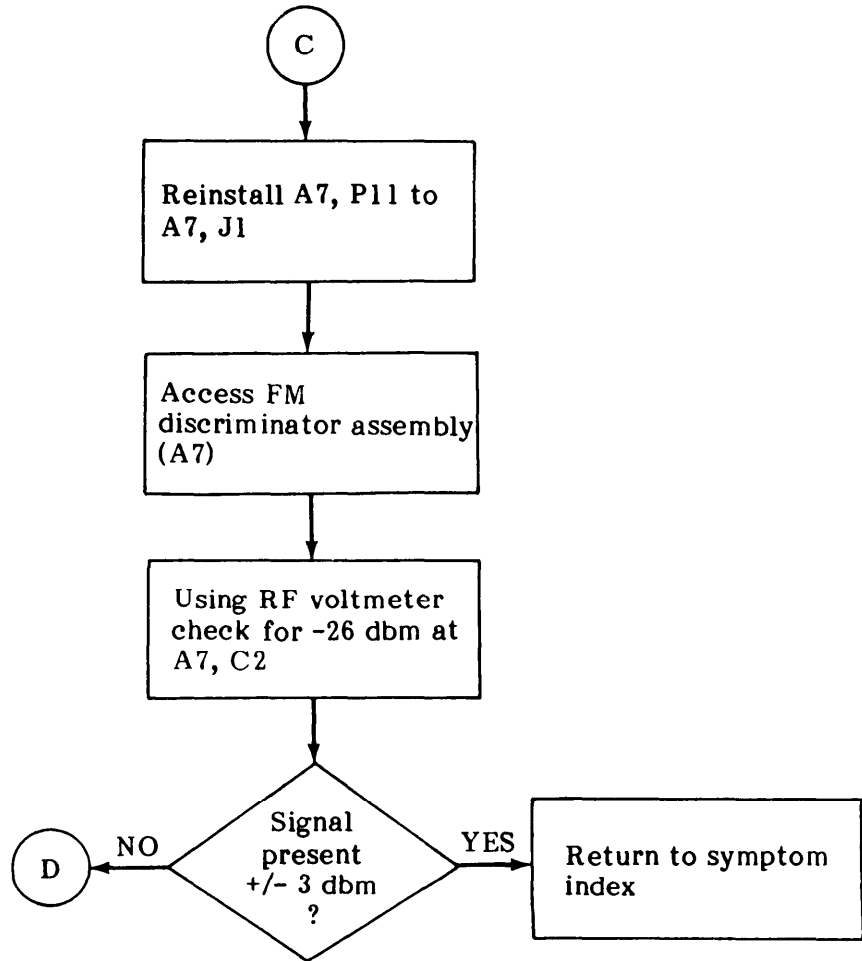
Level readings given reflect the use of the Boonton 91-8B 50 OHM adapter for all cable and connector measurements and the use of the Boonton 91-12F probe with tip at all circuit board measurements.

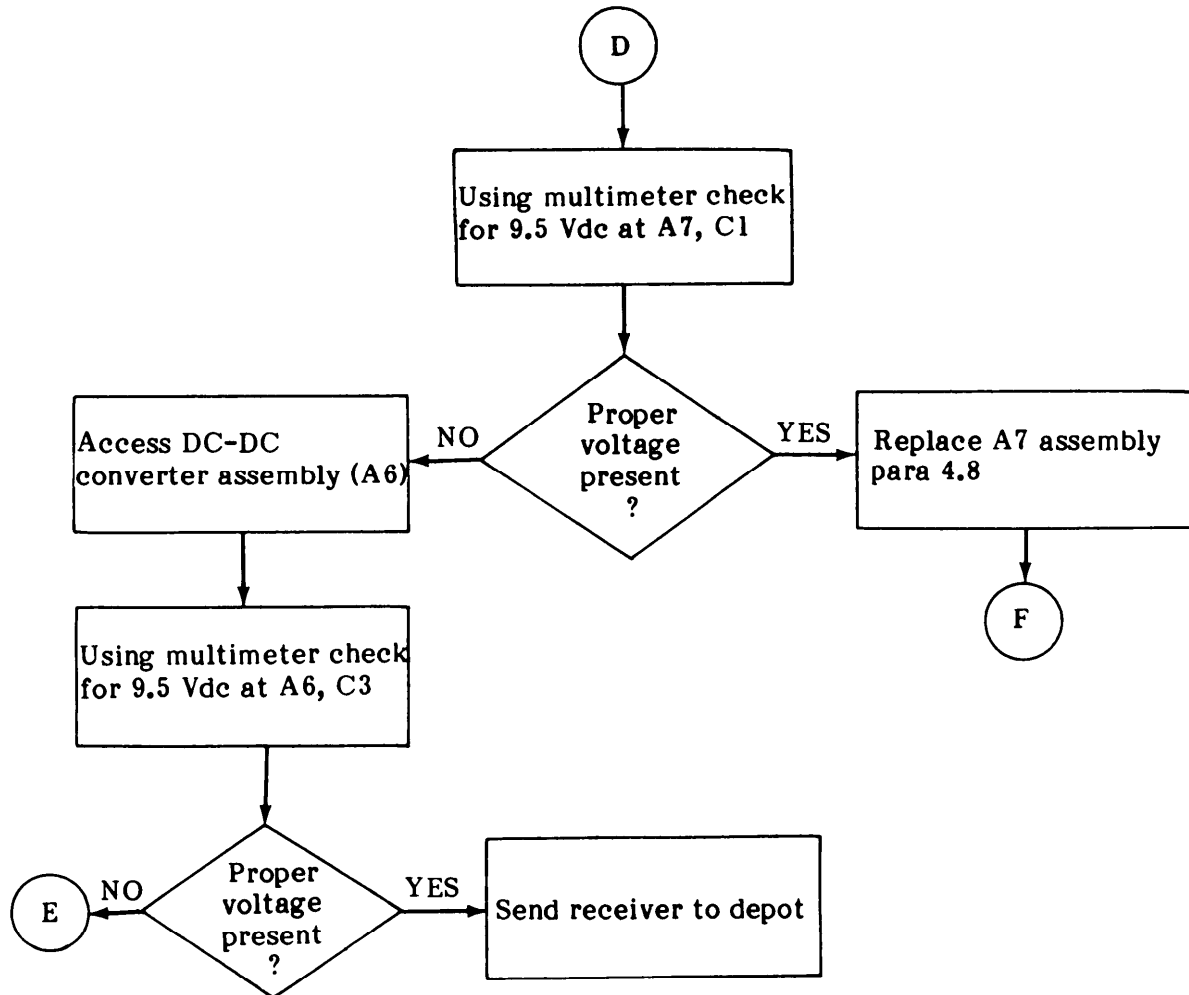
Minimum of 30 minutes warm-up time is required prior to starting troubleshooting procedures.

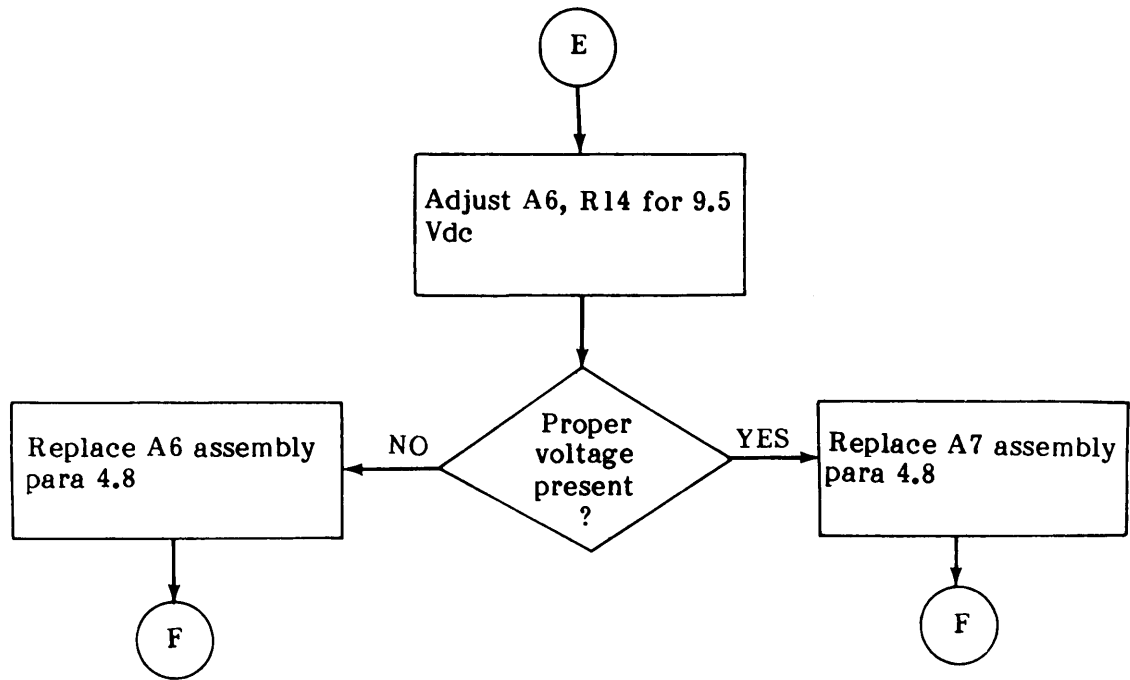
Courtesy of <http://BlackRadios.terryo.org>

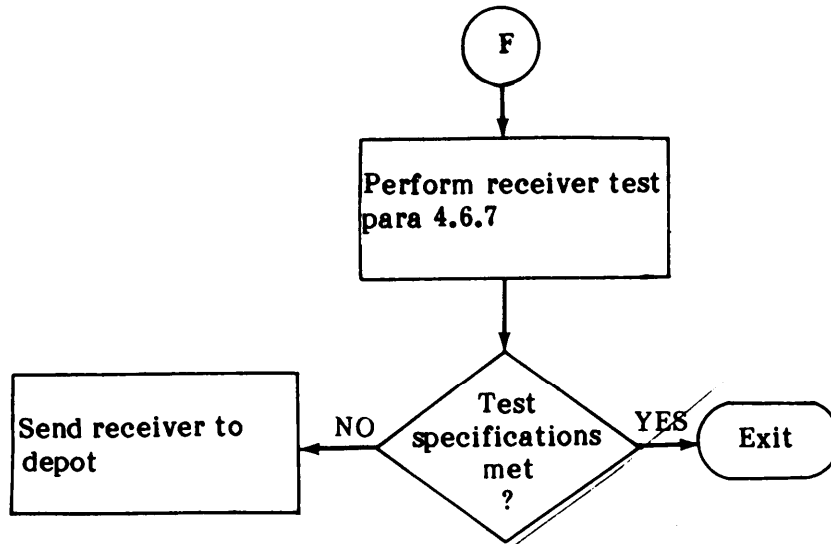












NO AUDIO WHEN SPEAKER ASSEMBLY IS USED

INITIAL SETUP

| | |
|---|--|
| <u>Test Equipment</u> | |
| Multi meter | AN/PSM-45 |
| Test Lead Set | Simpson 00577 |
| Signal Generator | SG-1112(V) 1/U w/options 001, 002 and 003 |
| Cable, RF, 50 ohms, 4', BNC-BNC | HP 10503A |
| RF Voltmeter | Boonton 92C |
| High Frequency Probe | Boonton 91-12F |
| Power Supply | PP 6547/U |
| Oscilloscope | AN/USM-281C |
| Voltage Probe, 10X | TEK P6006 |
| <u>Tools</u> | |
| $\frac{1}{4}$ Inch Flat Tip Screwdriver | 5120-00-222-8852 |
| No. 1 Phillips Screwdriver | 5120-00-240-8716 |
| <u>Replacement Parts</u> | |
| Audio Power Amp (A10A1) | 24999 |
| Speaker (A10, LS1) plug (Pi) and Cable | IAW-SM-C-620662 GC 329 |
| <u>Equipment Condition</u> | |
| POWER switch (S7) set to ON | |
| BAND (MHz) switch (S8) set to HIGH BAND | |
| Receiver tuned to 150 MHz | |
| MODE switch (S5) set to AM | |
| RF GAIN (R5) fully clockwise (not in AGC) | |
| VOLUME control (R 10) set to mid-range | |
| IF BANDWIDTH switch (S4) set to 10 KHz | |
| Front cover speaker connected to J4 | |
| Receiver cover removed | |
| Signal generator set to 150 MHz AM -30 dbm @ 400Hz 50% | |
| Signal generator connected to RF IN (J1) | |
| RF voltmeter referenced to signal generator and set to read -25 dbm | |
| RF voltmeter connected to SM OUTPUT (J2) | |
| Power supply set to 24 Vdc | |
| Power supply connected to J5 | |
| WJ-9121 [TN-584/GRR8(V)] Tuner installed | |

NOTE

Level readings given reflect the use of the Boonton 91-8B 50 OHM adapter for all cable and connector measurements and the use of the Boonton 91-12F probe with tip at all circuit board measurements.

Minimum of 30 minutes warm-up time is required prior to starting troubleshooting procedures.

Courtesy of <http://BlackRadios.terryo.org>

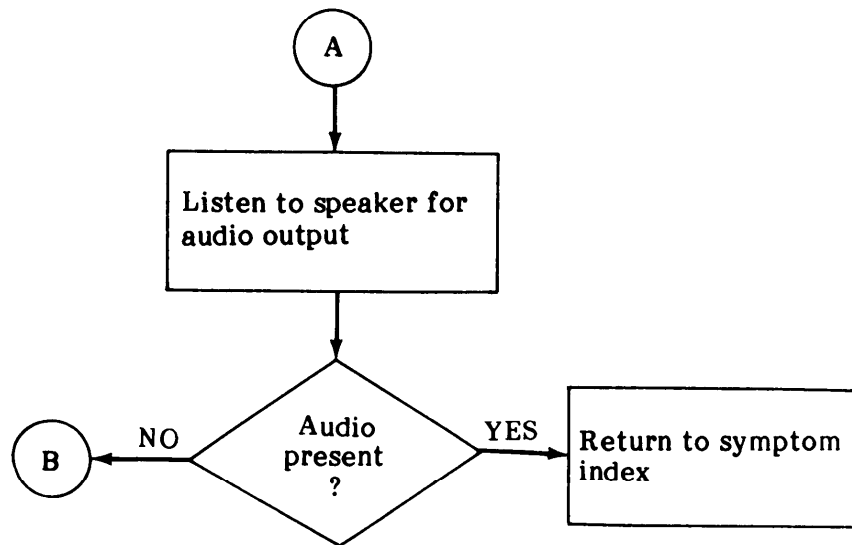
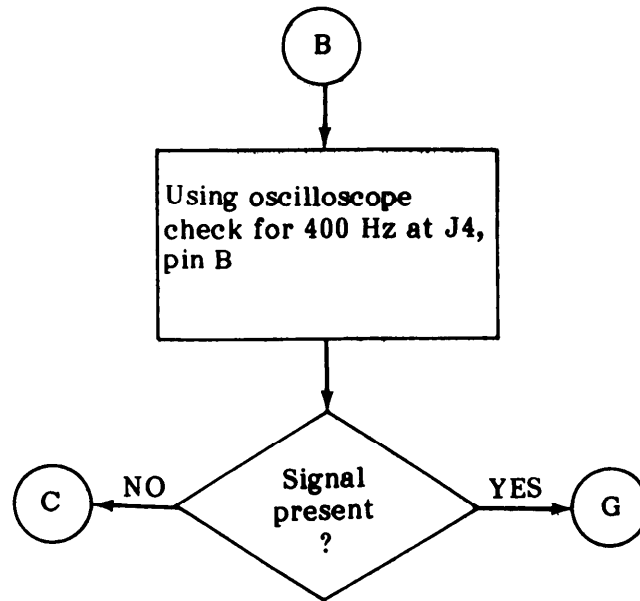
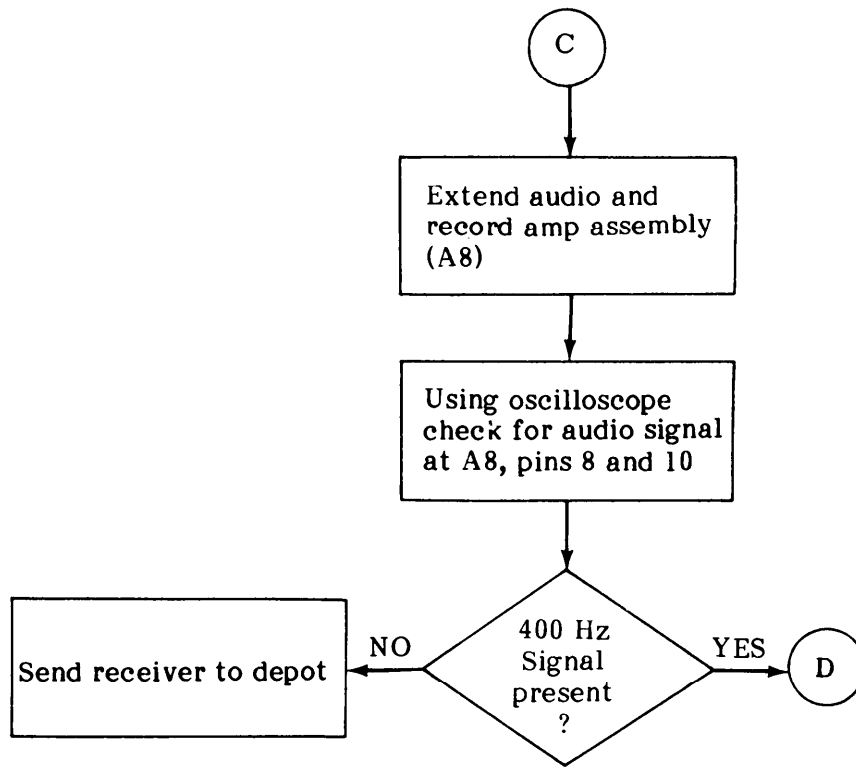
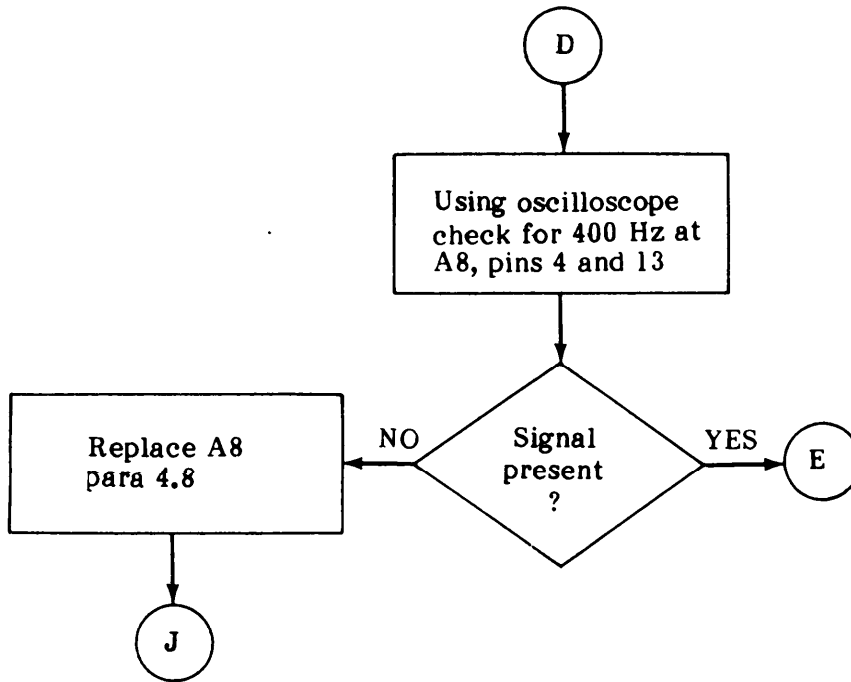
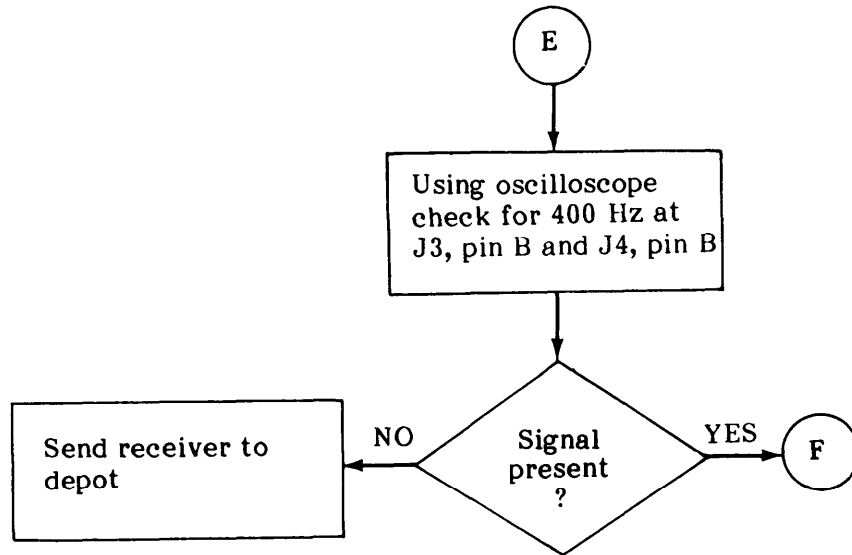


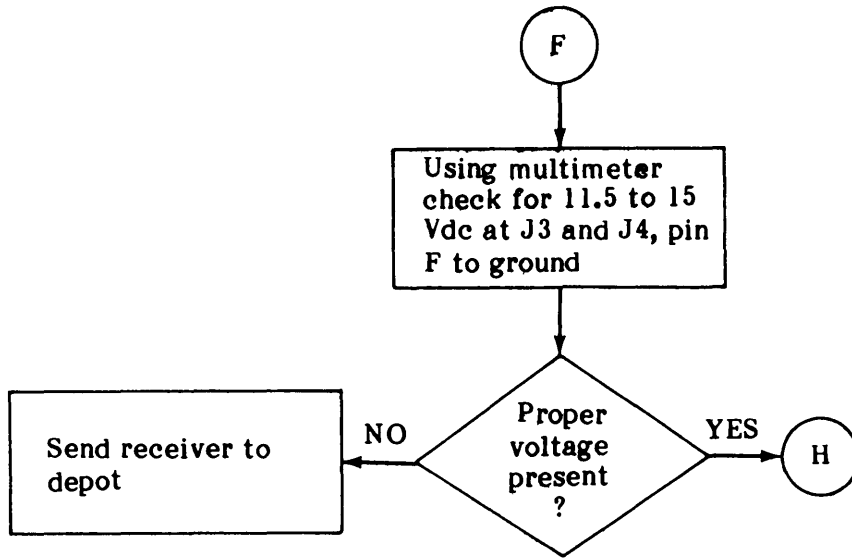
TABLE 4-1

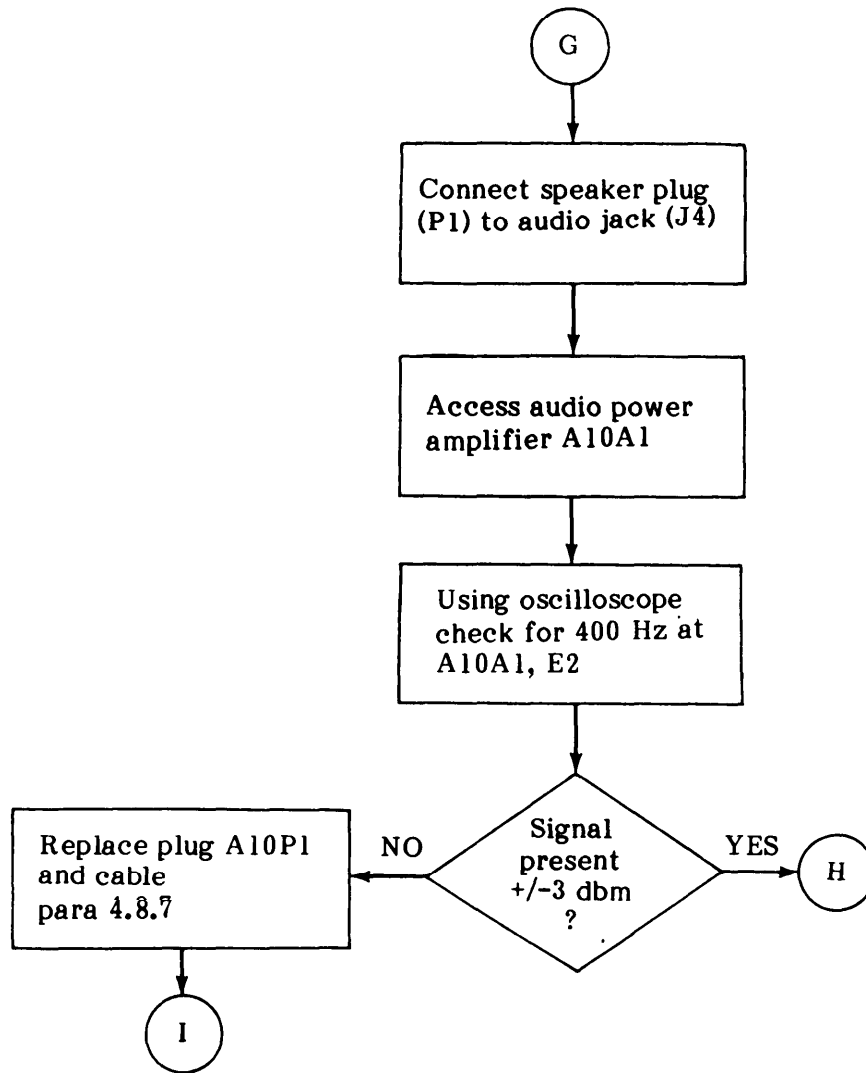


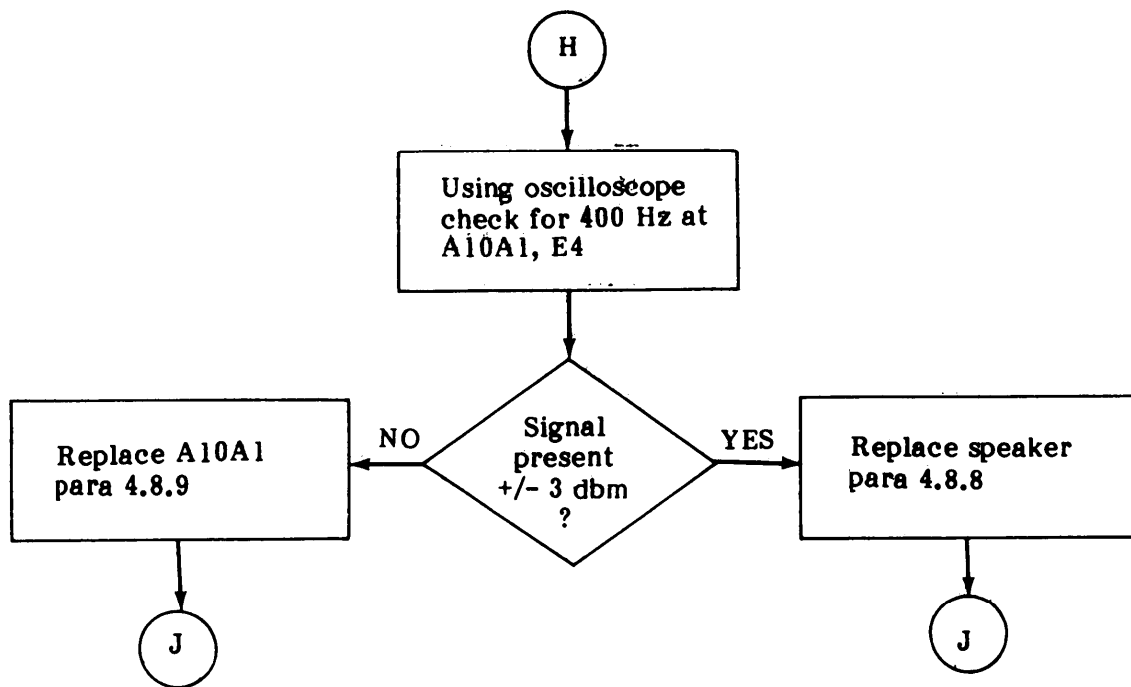


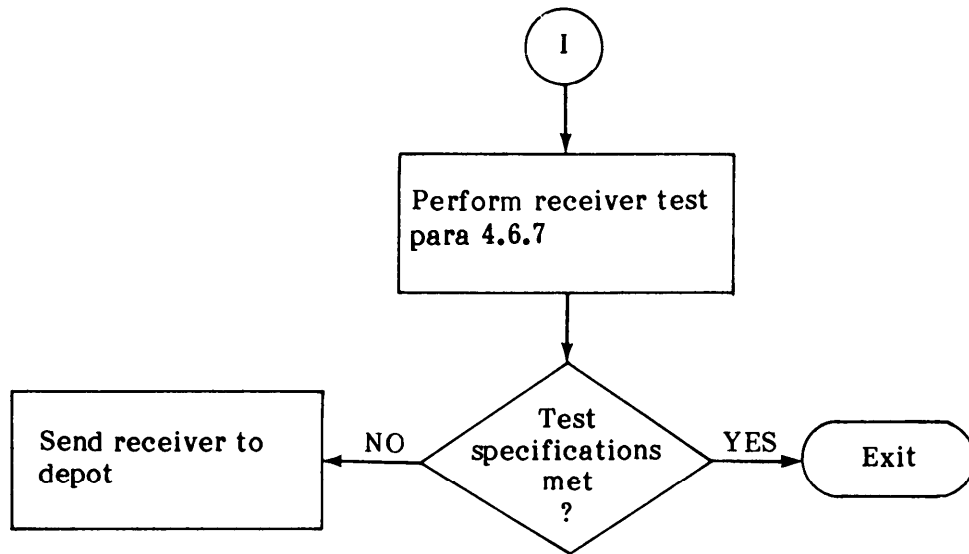












Courtesy of <http://BlackRadios.terryo.org>

FREQUENCY MHz DISPLAY THAT DOES NOT LIGHT

INITIAL SETUP

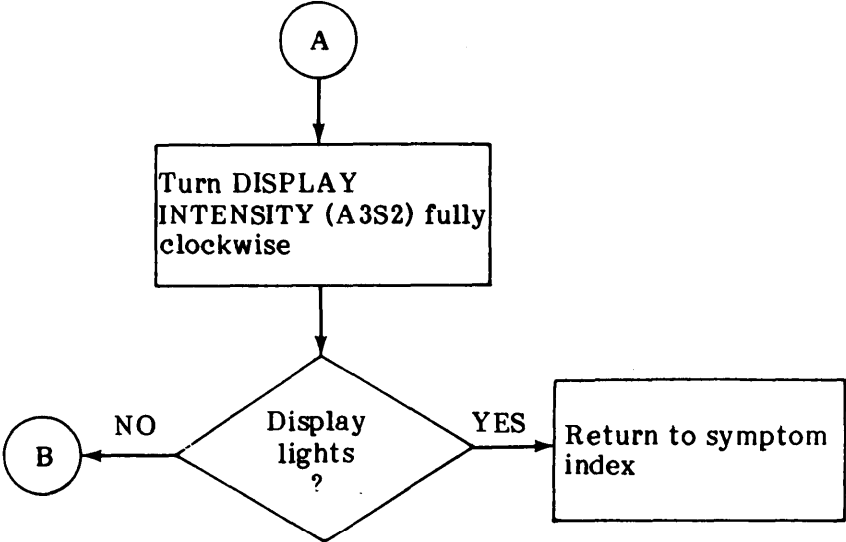
| | |
|--|------------------|
| <u>Test Equipment</u> | |
| Multimeter | AN/PSM-45 |
| Test Lead Set | Simpson 00577 |
| 50 ohm Adapter | Boonton 91-8B |
| Power Supply | PP-6547/U |
| Oscilloscope | AN/USM-281C |
| Voltage Probe, 10X | TEK P6006 |
| <u>Tools</u> | |
| No. 1 Phillips Screwdriver | 5120-00-240-8617 |
| <u>Replacement Parts</u> | |
| Display Board (A3A1A1) | 24947 |
| DC-DC Converter (A6) | 791794 |
| <u>Equipment Condition</u> | |
| Power switch (S7) set to ON | |
| BAND (MHz) switch (S8) set to HIGH | |
| Receiver tuned to 150 MHz | |
| Receiver cover removed | |
| Power supply set to 24 Vdc | |
| Power supply connected to J5 | |
| WJ-9121 [TN-584/GRR8(V)] Tuner installed | |

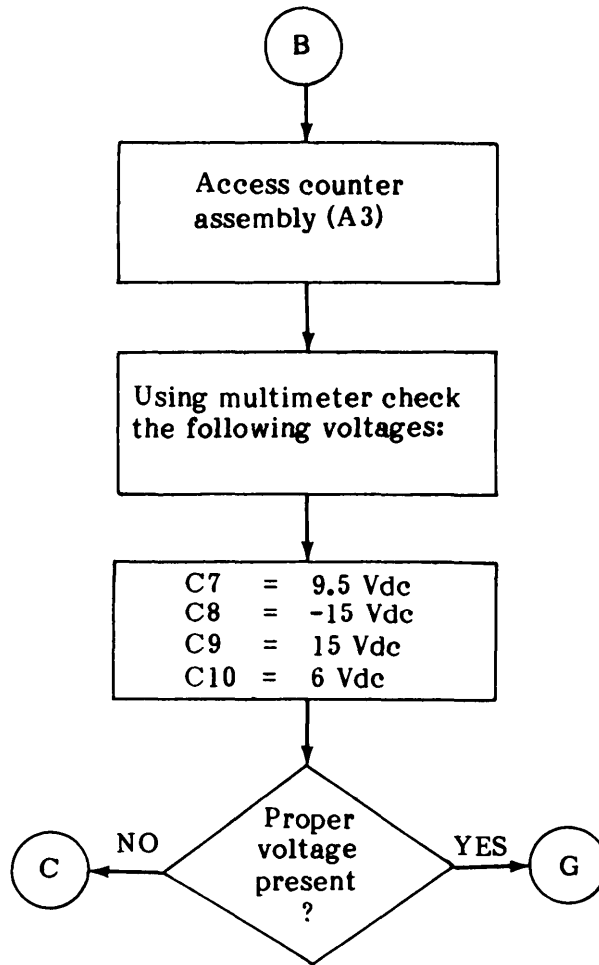
NOTE

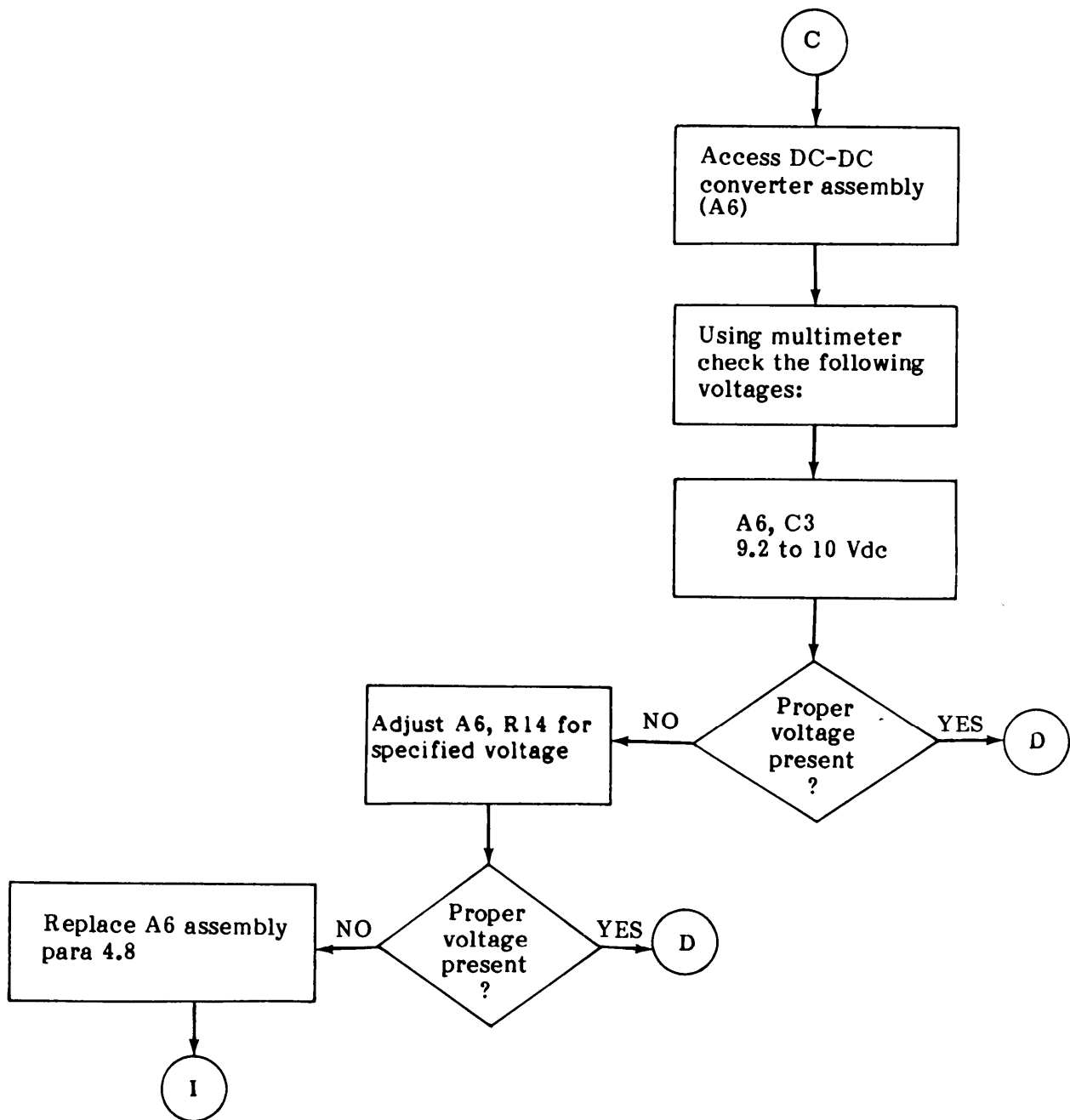
Level readings given reflect the use of the Boonton 91-8B 50 OHM adapter for all cable and connector measurements and the use of the Boonton 91-12F probe with tip at all circuit board measurements.

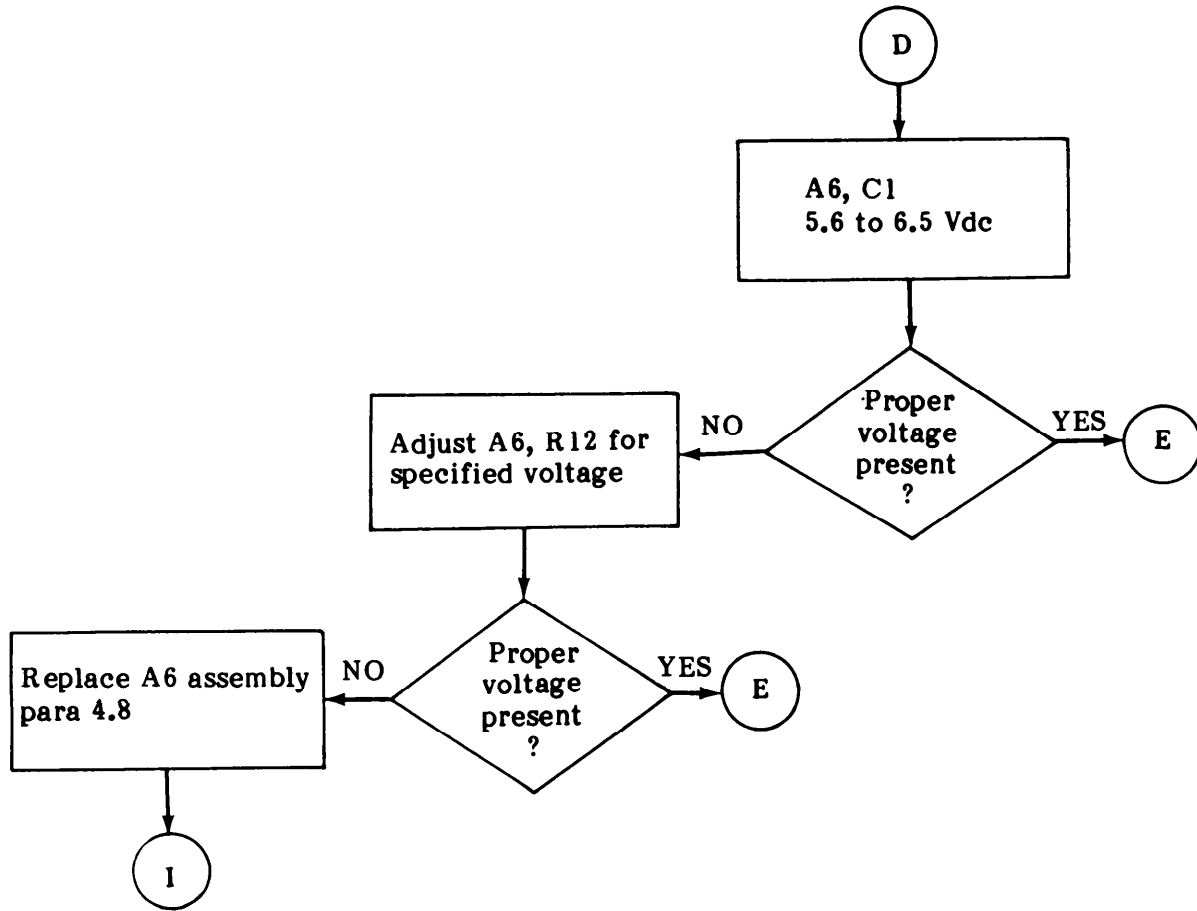
Minimum of 30 minutes warm-up time is required prior to starting troubleshooting procedures.

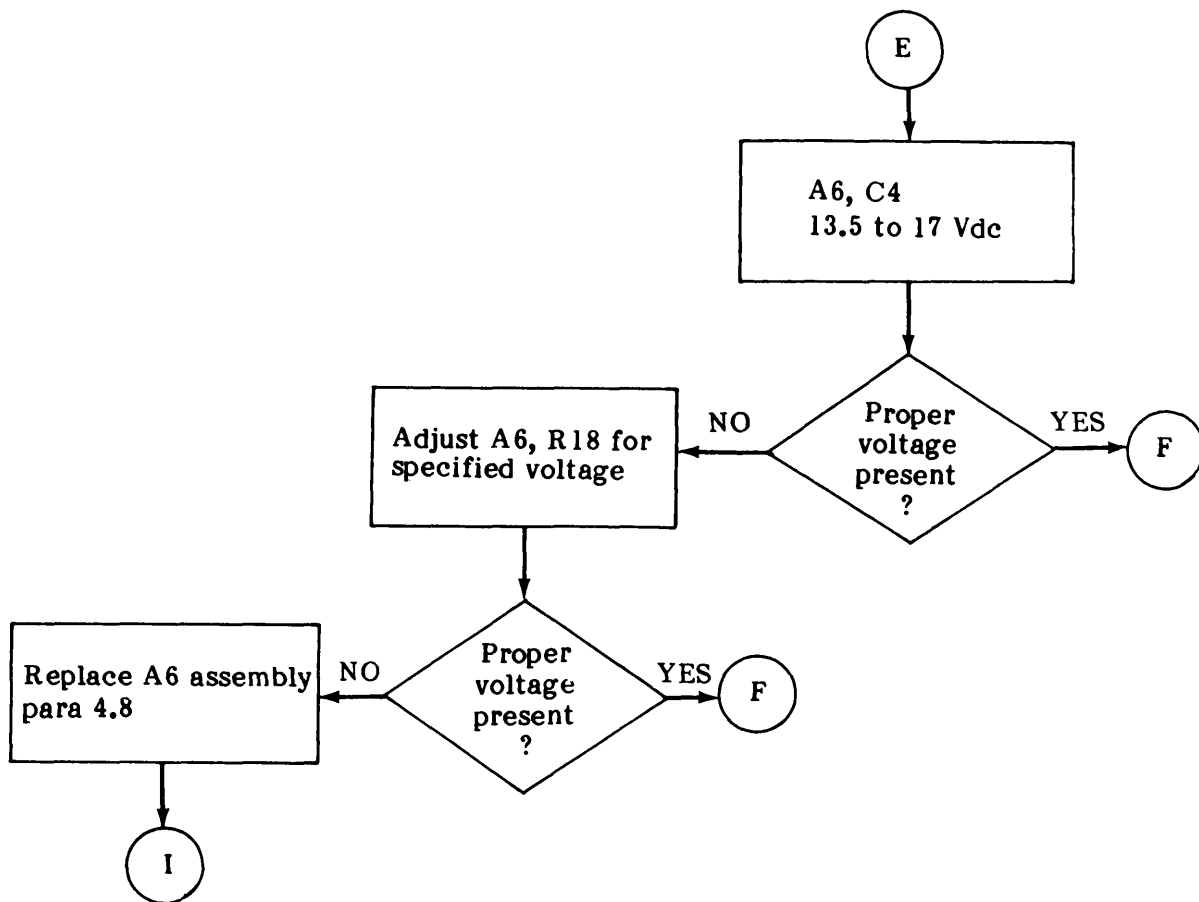
Courtesy of <http://BlackRadios.terryo.org>

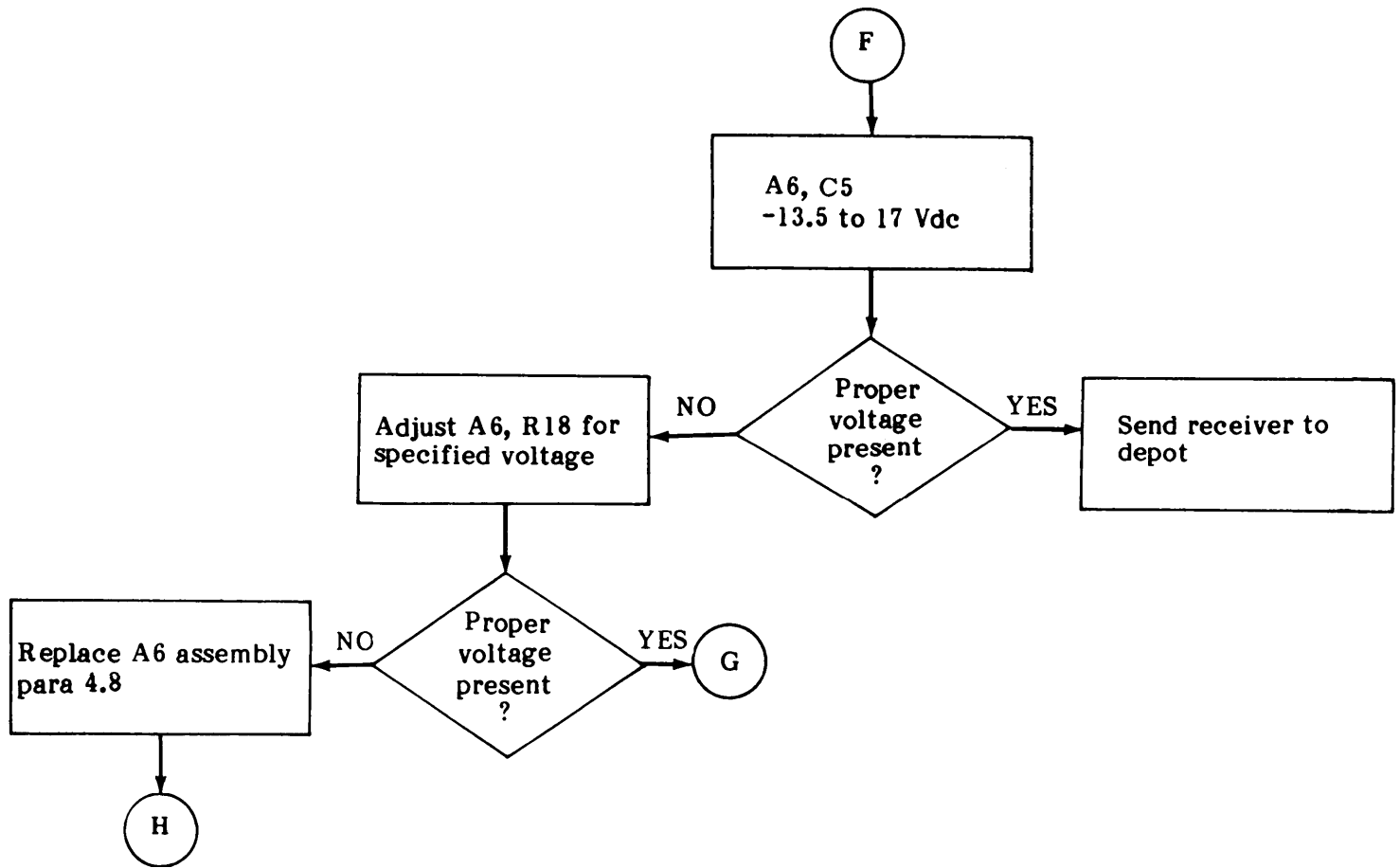












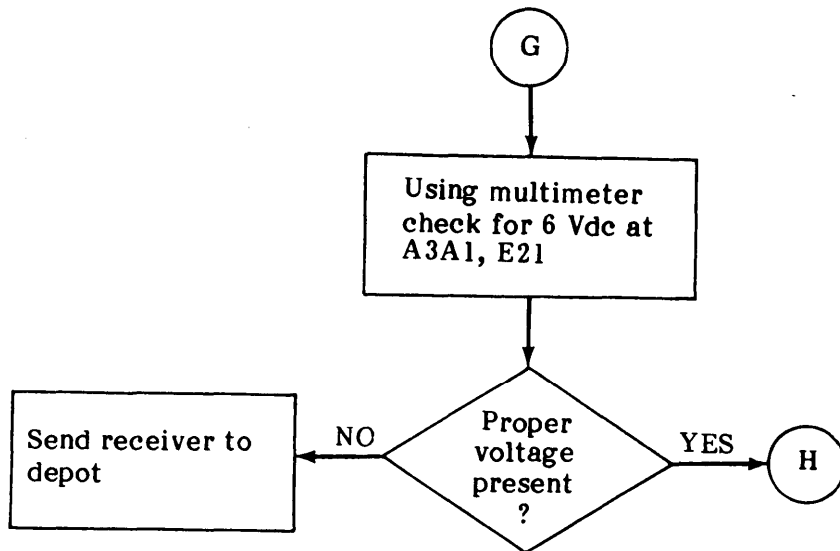
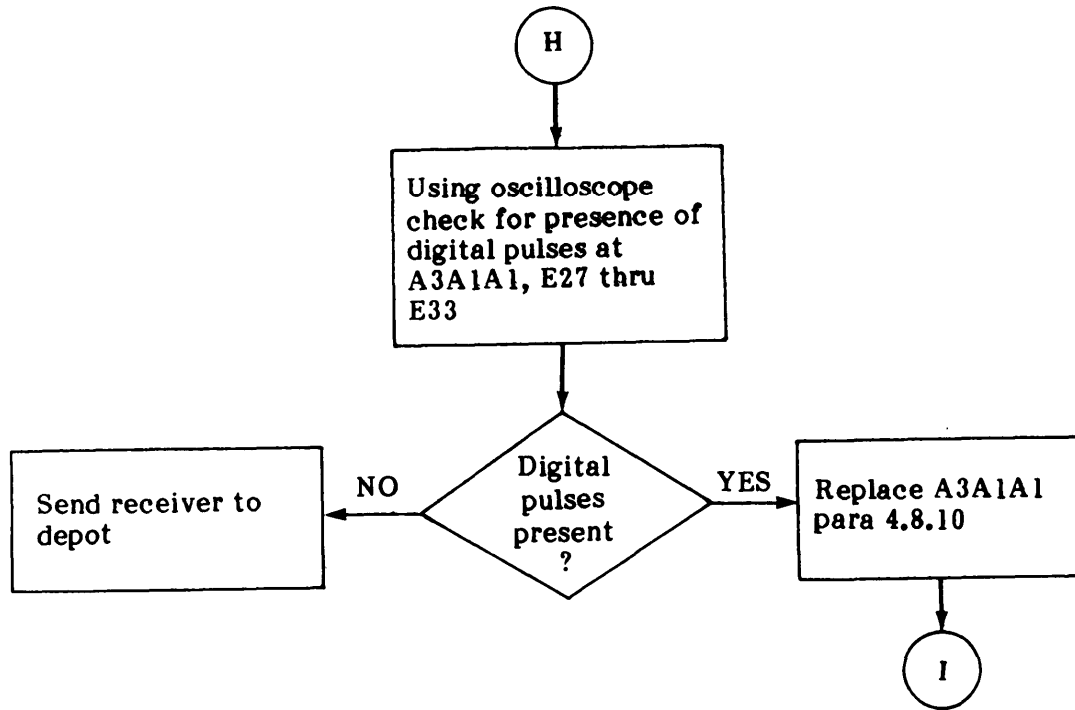
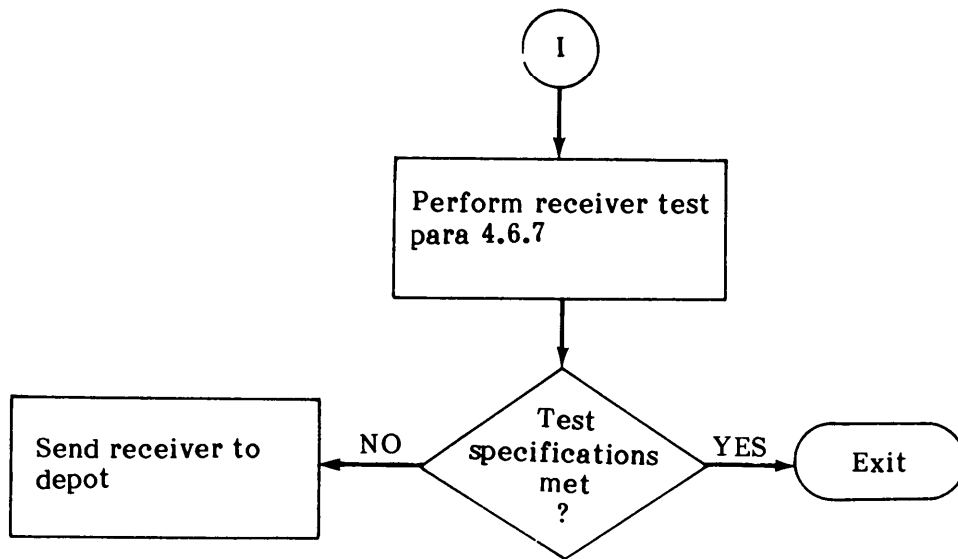


TABLE 4-1





Courtesy of <http://BlackRadios.terryo.org>

FREQUENCY MHz DISPLAY THAT CHANGES FREQUENCY WHEN DAFC LOCK SWITCH IS SET TO LOCK POSITION

INITIAL SETUP

| | |
|------------------------------------|------------------|
| <u>Test Equipment</u> | |
| Multimeter | AN/PSM-45 |
| Test Lead Set | Simpson 00577 |
| Power Supply | PP-6547/U |
| | |
| <u>Tools</u> | |
| No. 1 Phillips Screwdriver | 5120-00-240-8716 |
| | |
| <u>Replacement parts</u> | |
| Counter Board (A3A1) | 791808 |
| DC-DC Converter (A6) | 791794 |
| | |
| <u>Equipment Condition</u> | |
| POWER switch (S7) set to ON | |
| BAND (MHz) switch (S8) set to HIGH | |
| Receiver tuned to 150 MHz | |
| Receiver cover removed | |
| Power supply set to 24 Vdc | |
| Power supply connected to J5 | |
| Tuner assembly installed | |
| WJ-9121 [TN-584/GRR8(V)] | |

NOTE

Level readings given reflect the use of the Boonton 91-8B 50 OHM adapter for all cable and connector measurements and the use of the Boonton 91-12F probe with tip at all circuit board measurements.

Minimum of 30 minutes warm-up time is required prior to starting troubleshooting procedures.

Courtesy of <http://BlackRadios.terryo.org>

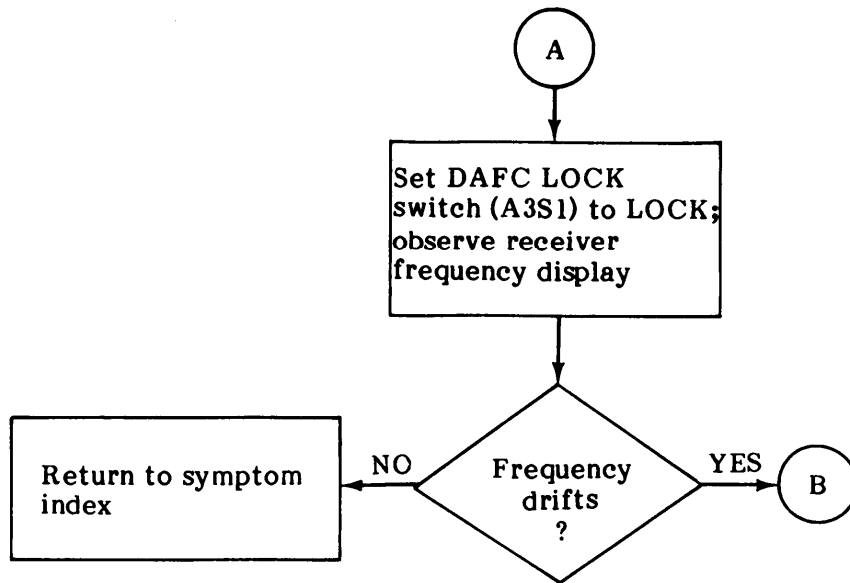
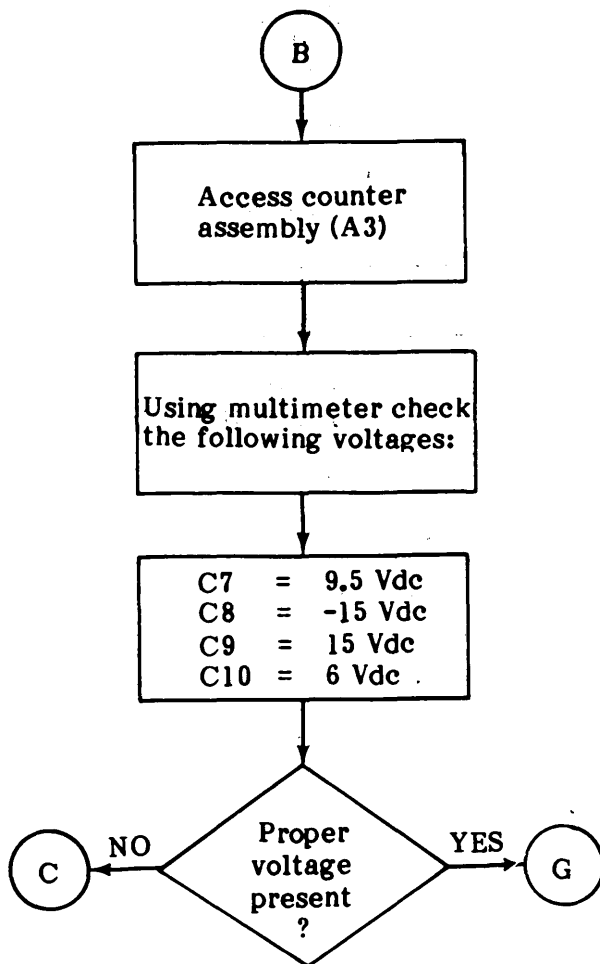
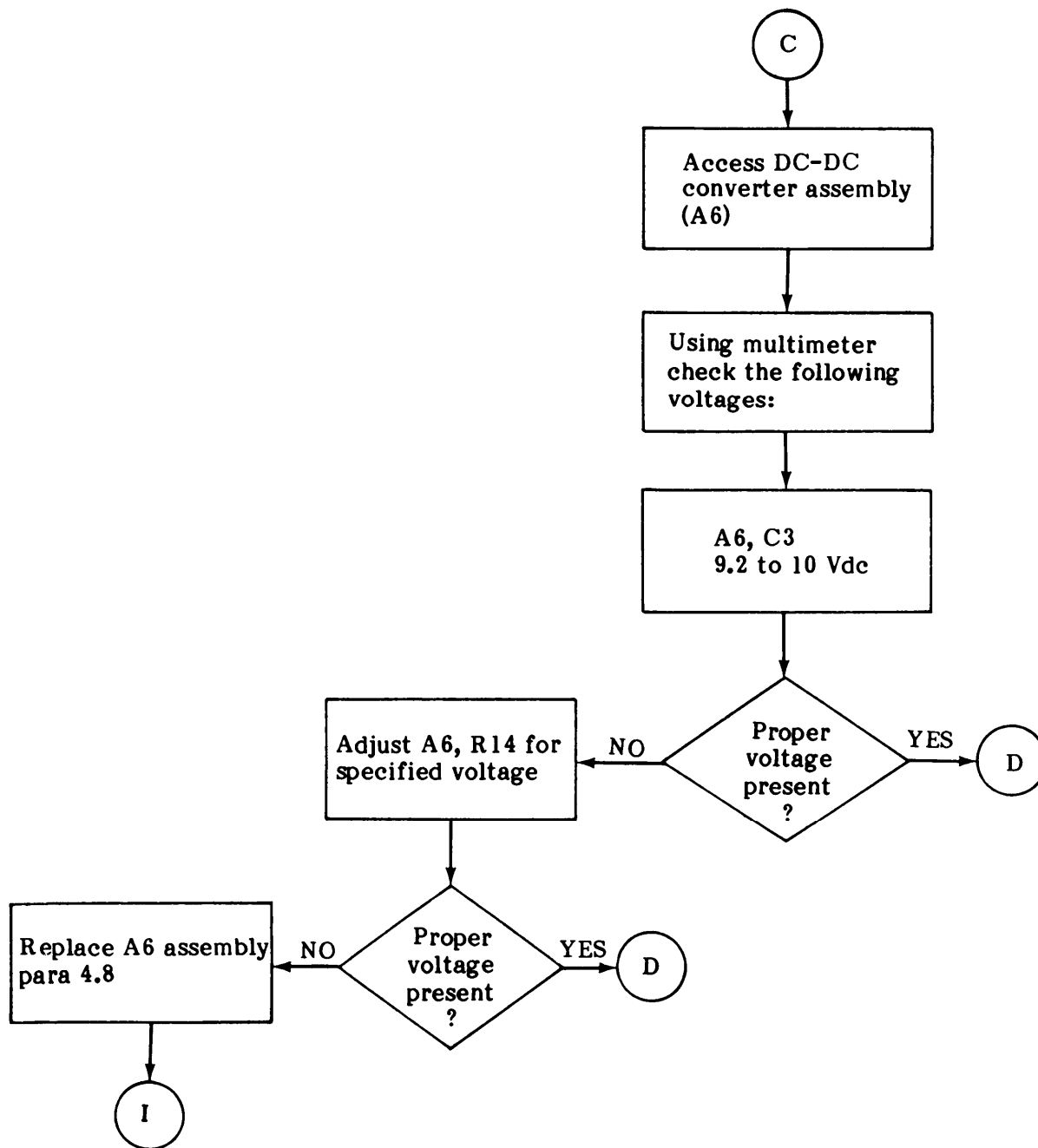
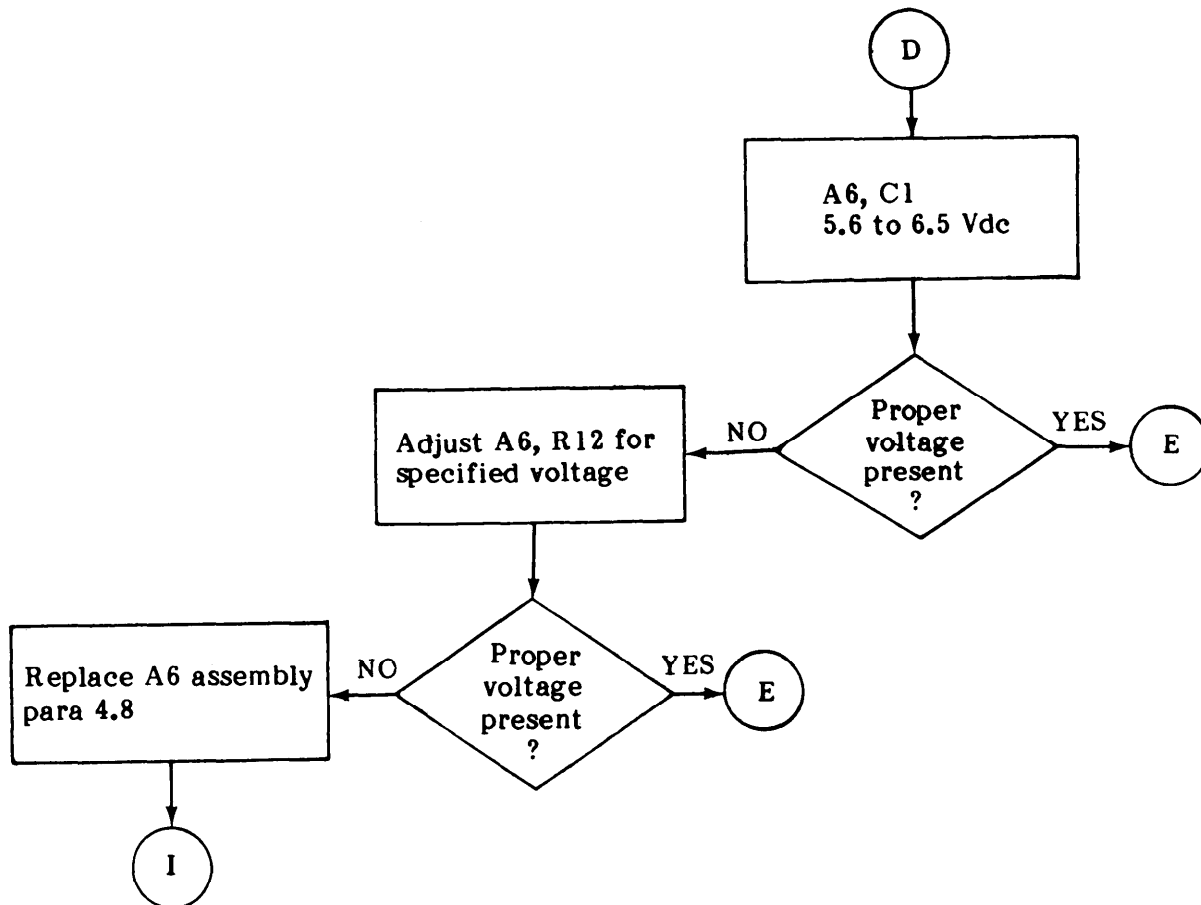
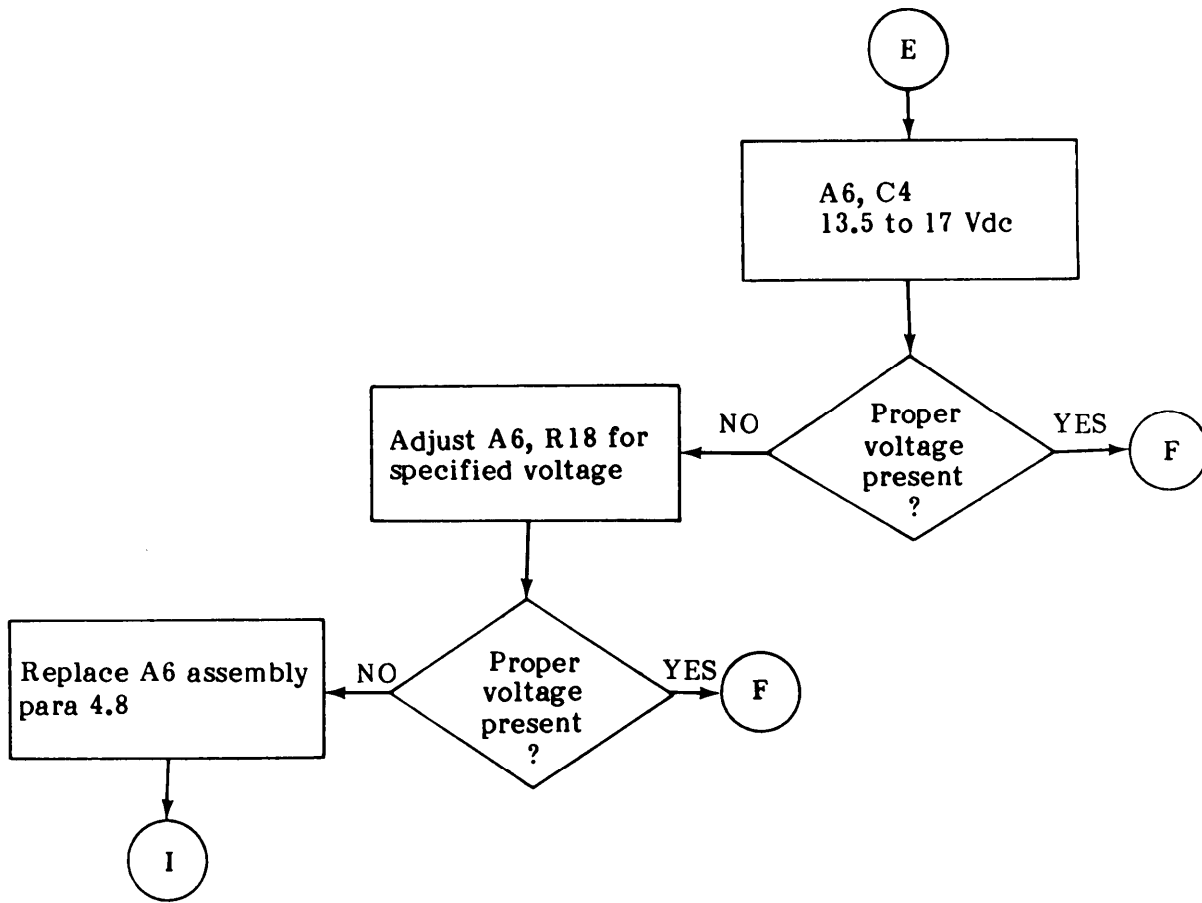


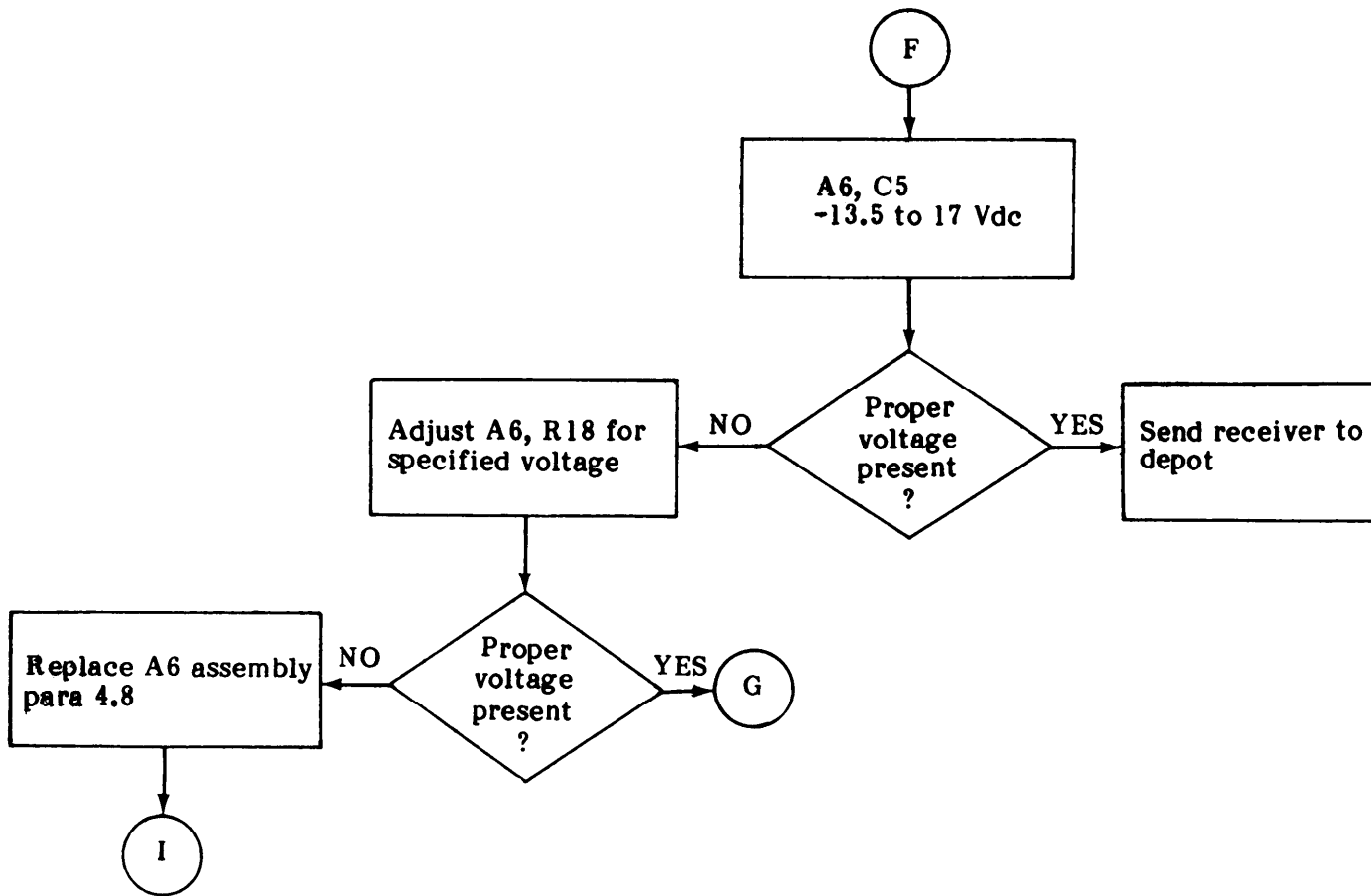
TABLE 4-1

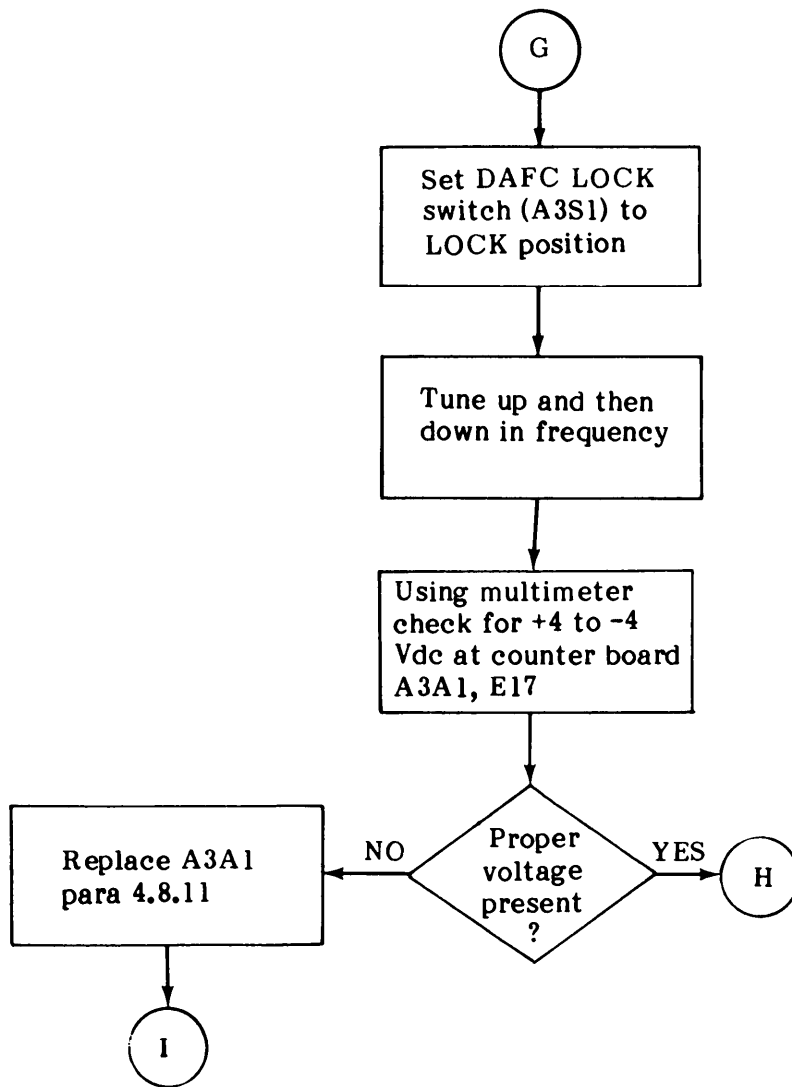


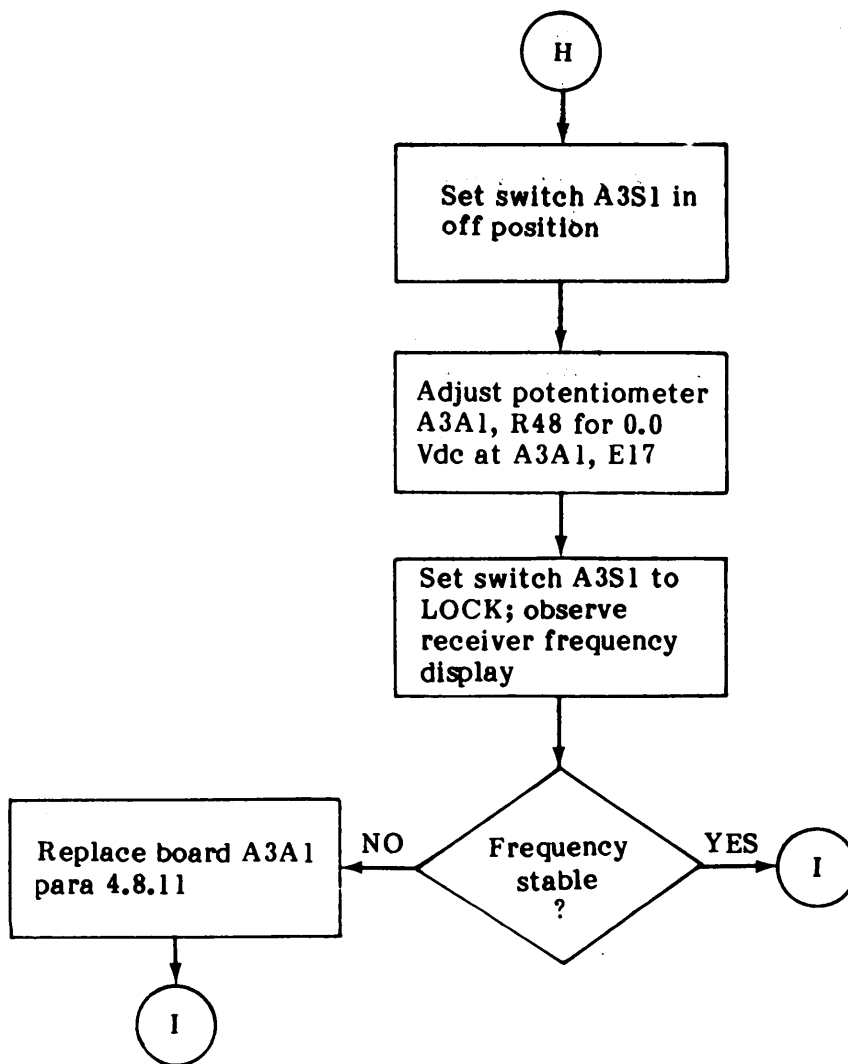


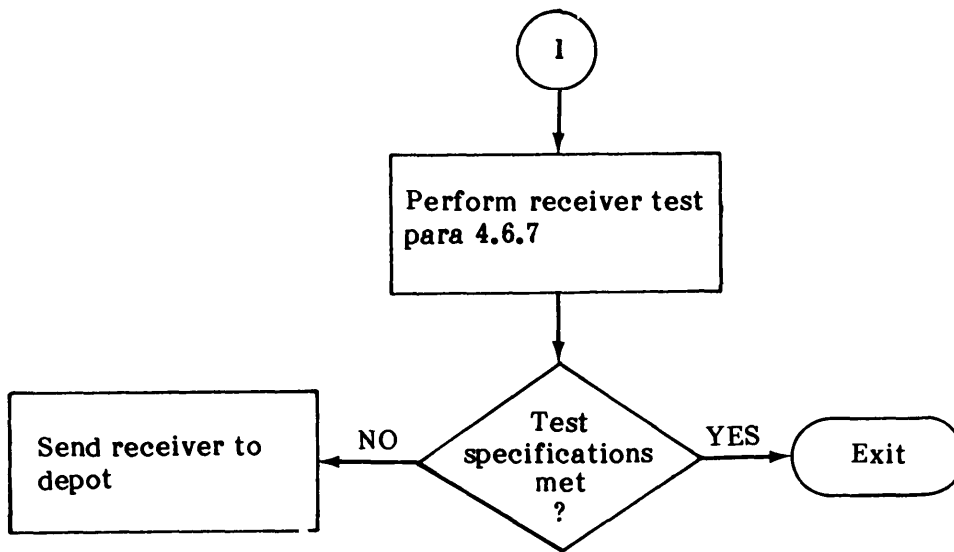












Courtesy of <http://BlackRadios.terryo.org>

FREQUENCY MHz DISPLAY THAT LOCKS AT A PRESET FREQUENCY

INITIAL SETUP

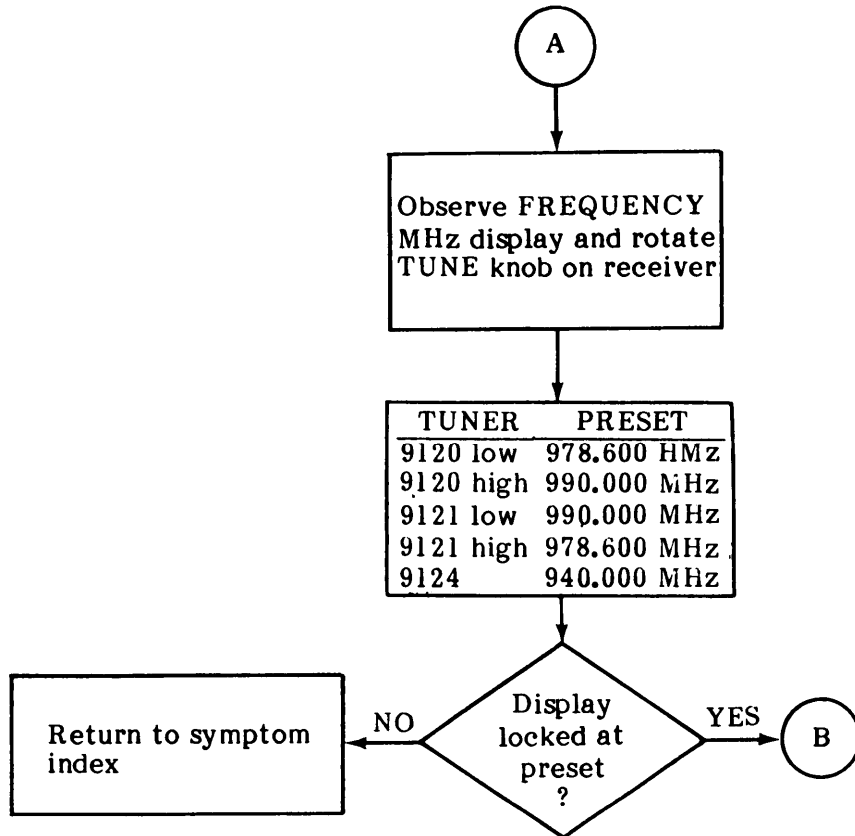
| | |
|--|--|
| <u>Test Equipment</u> | |
| Multimeter | AN/PSM-45 |
| Test Lead Set | Simpson 00577 |
| Signal Generator | SG-1112(V) I/U w/options 001, 002 and 003 |
| Cable, RF, 50 ohms, 4', BNC-BNC | HP 10503A |
| RF Voltmeter | Boonton 92C |
| High Frequency Probe | Boonton 91-12F |
| 50 ohm Adapter | Boonton 91-8B |
| Power Supply | PP-6547/U |
| <u>Tools</u> | |
| No. 1 Phillips Screwdriver | 5120-00-240-8716 |
| <u>Replacement Parts</u> | |
| DC-DC Converter (A6) | 791794 |
| Tuner (A2) | TN-584/GRR-8(V) |
| Cable (A3W1) | 17300-148-8 |
| Cable (A3W2) | 17300-148-9 |
| <u>Equipment Condition</u> | |
| POWER switch (S7) set to ON | |
| BAND SELECT switch (S8) set to HIGH | |
| Receiver tuned to 150 MHz | |
| Receiver cover removed | |
| Power supply set to 24 Vdc | |
| Power supply connected to J5 | |
| WJ-9121 [TN-584/GRR8(V)] Tuner installed | |

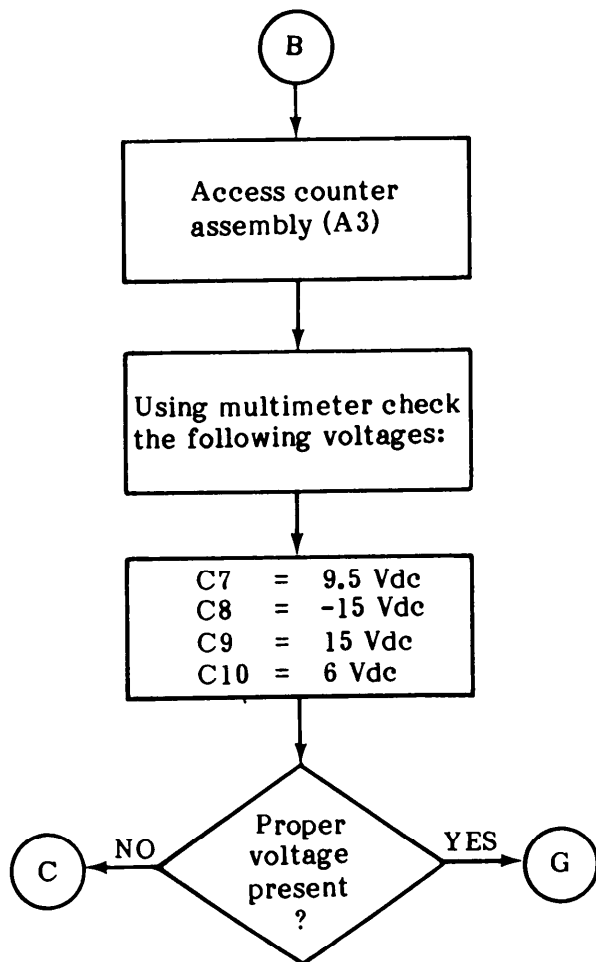
NOTE

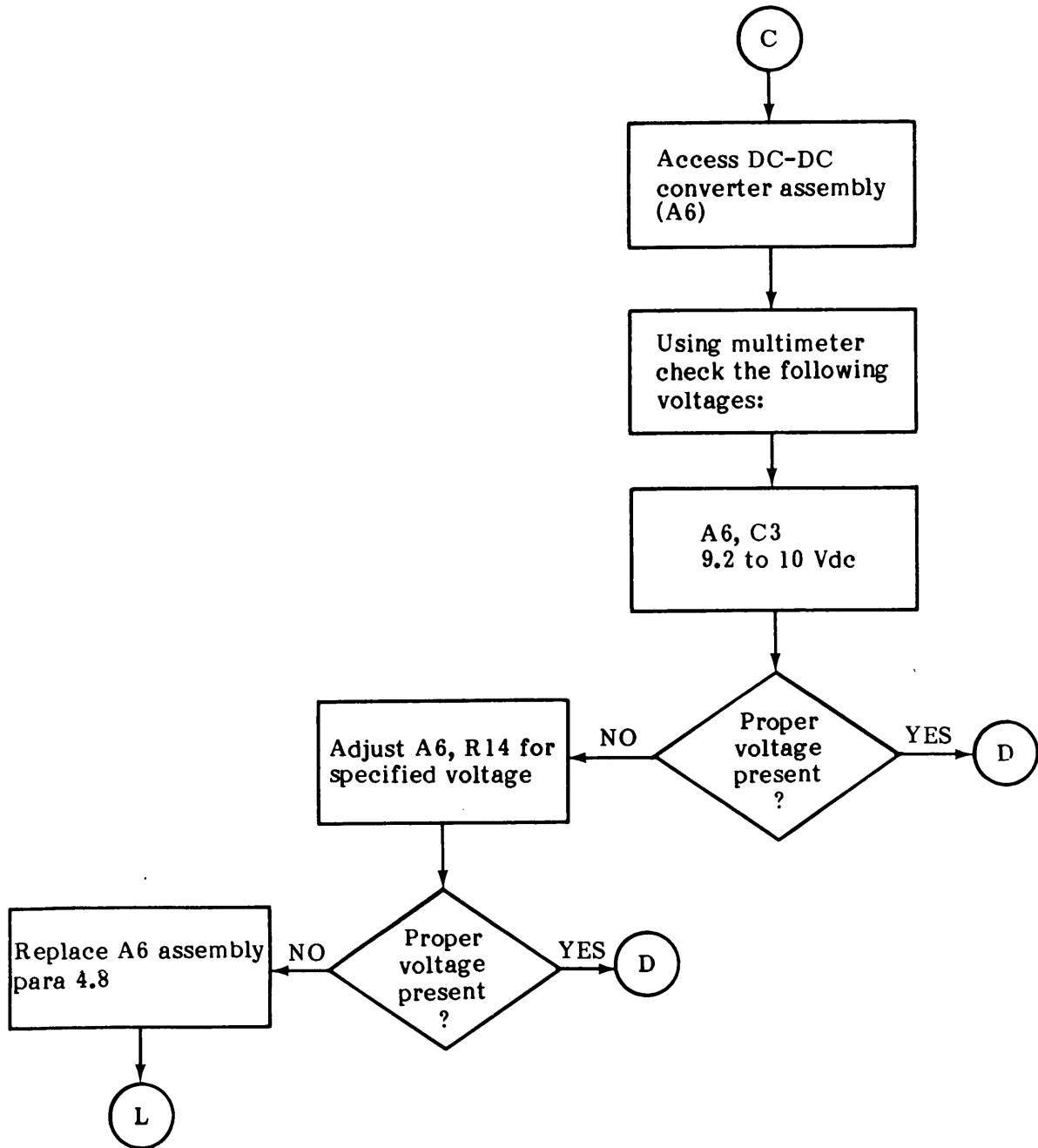
Level readings given reflect the use of the Boonton 91-8B 50 OHM adapter for all cable and connector measurements and the use of the Boonton 91-12F probe with tip at all circuit board measurements.

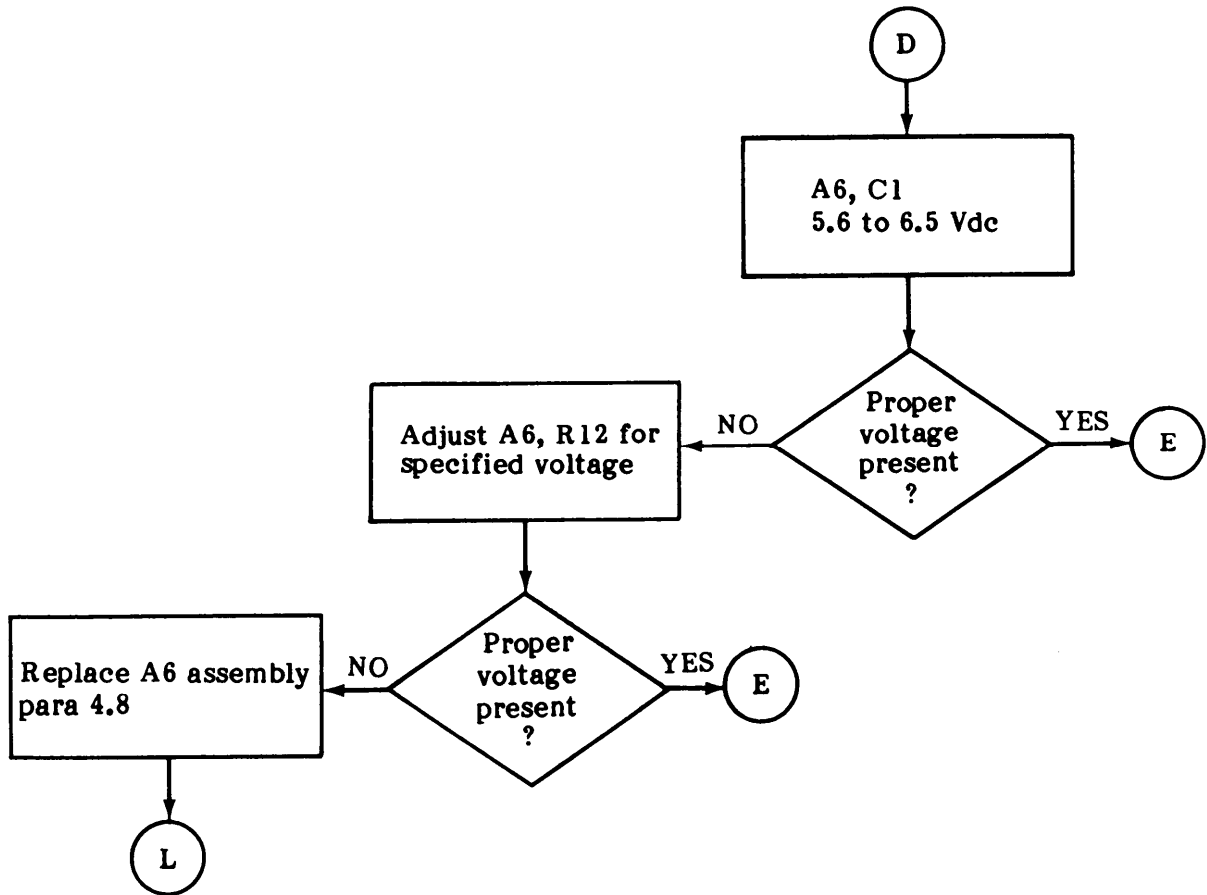
Minimum of 30 minutes warm-up time is required prior to starting troubleshooting procedures.

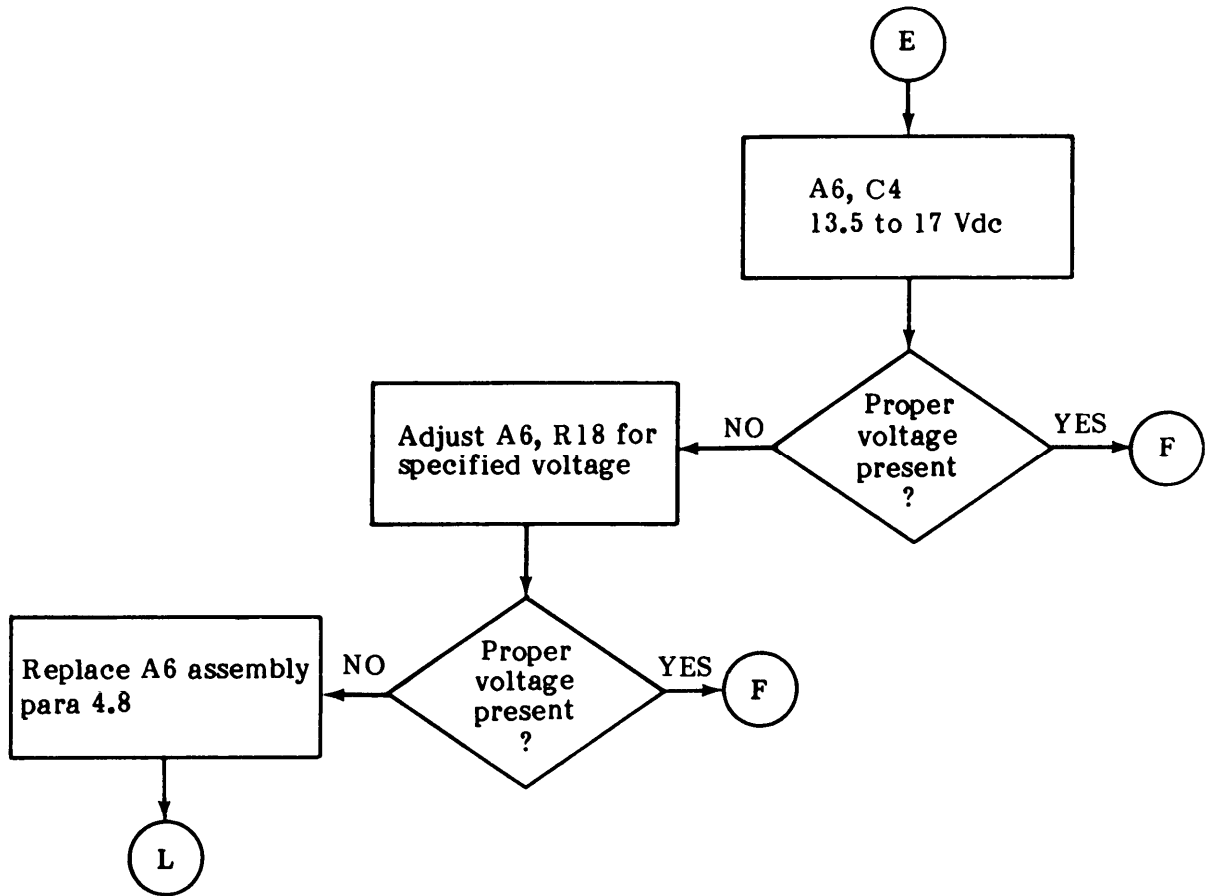
Courtesy of <http://BlackRadios.terryo.org>

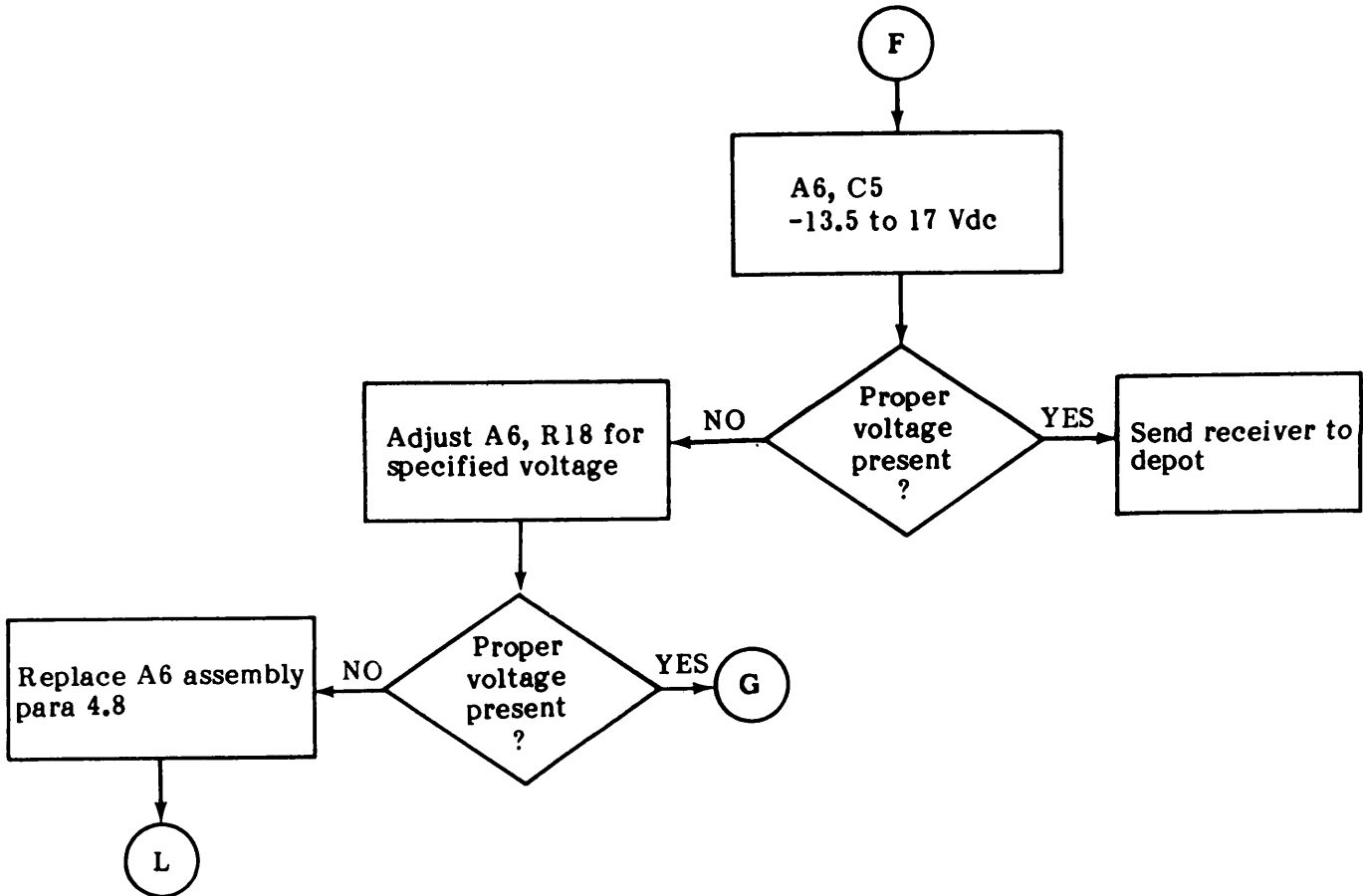


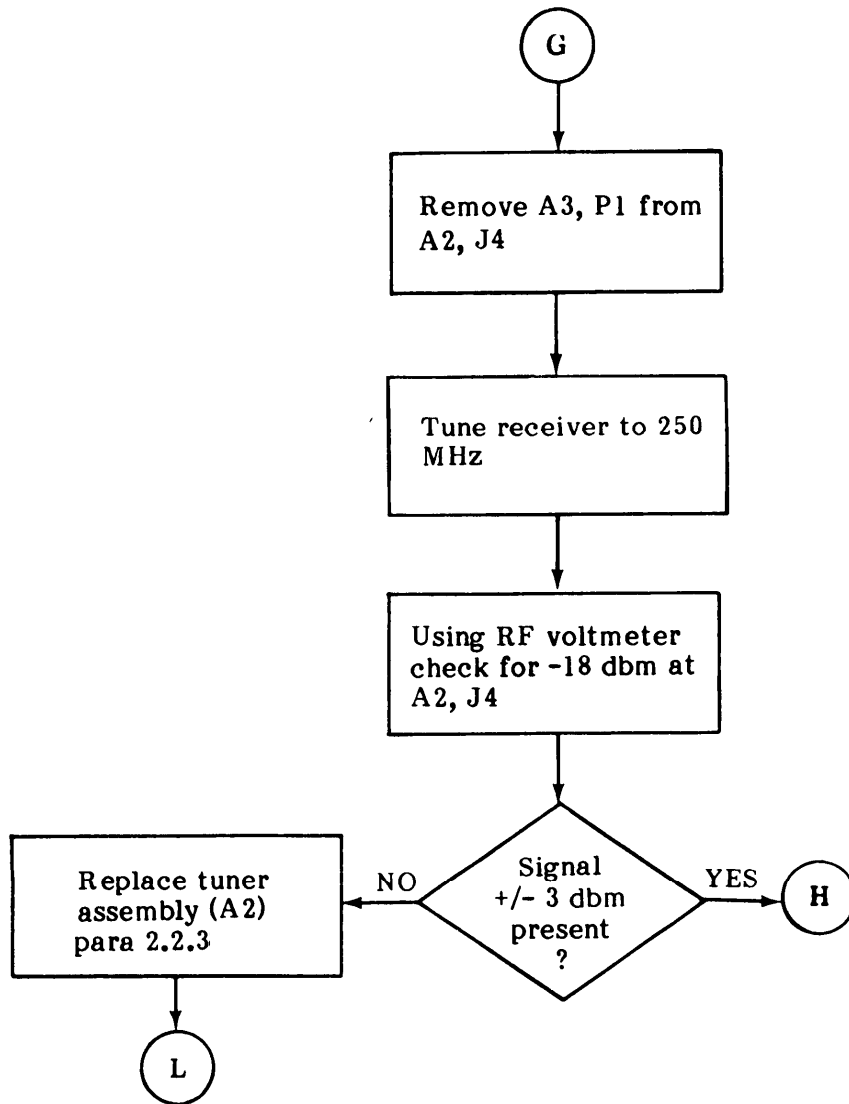


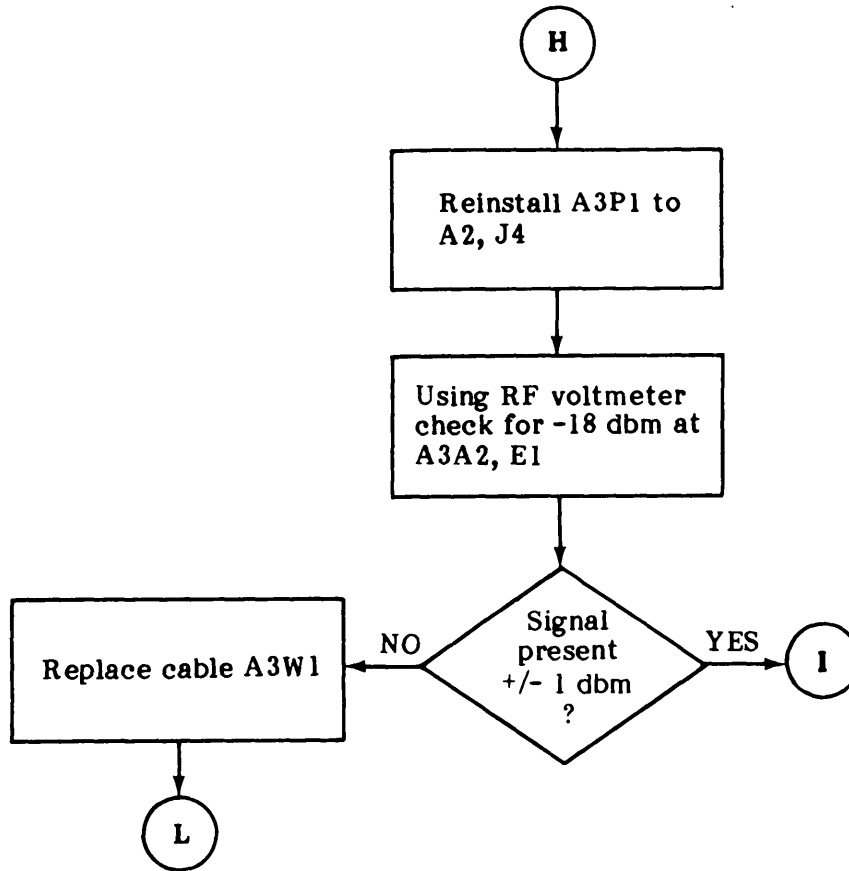


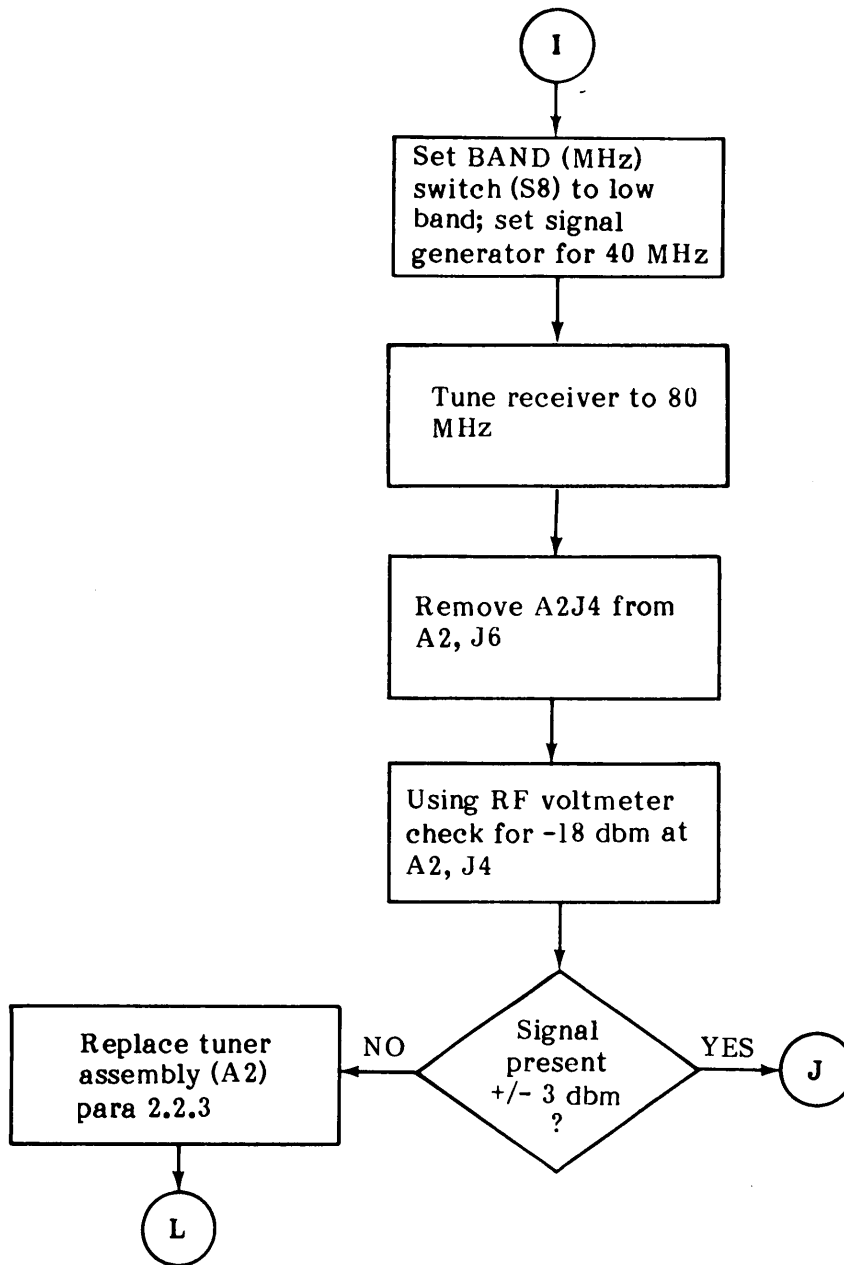


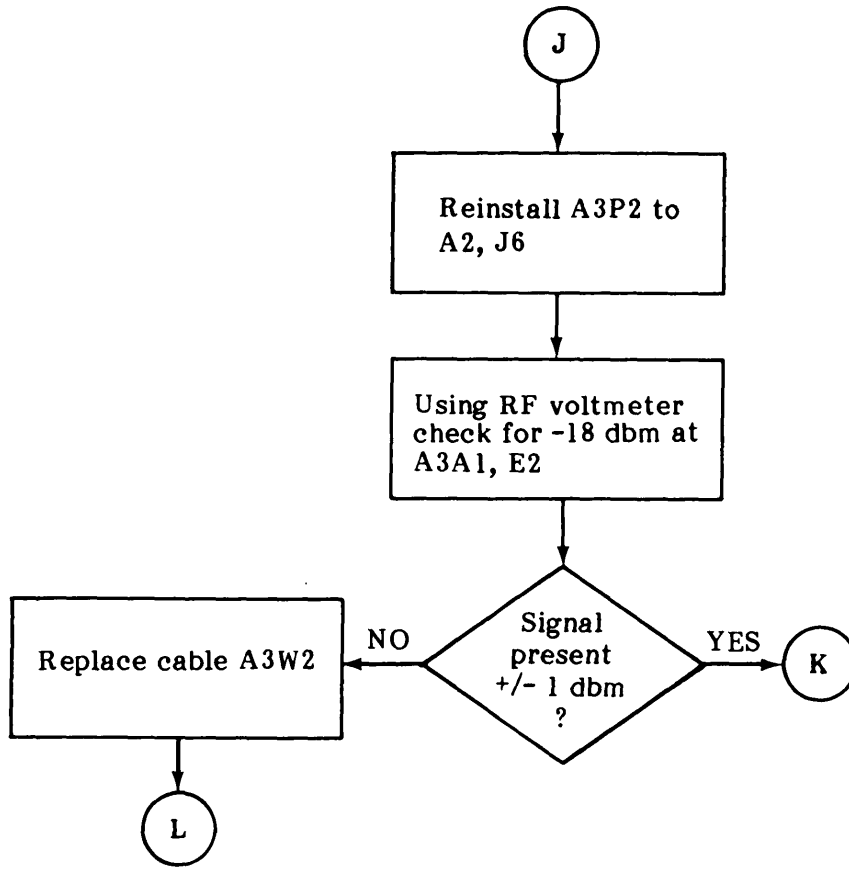


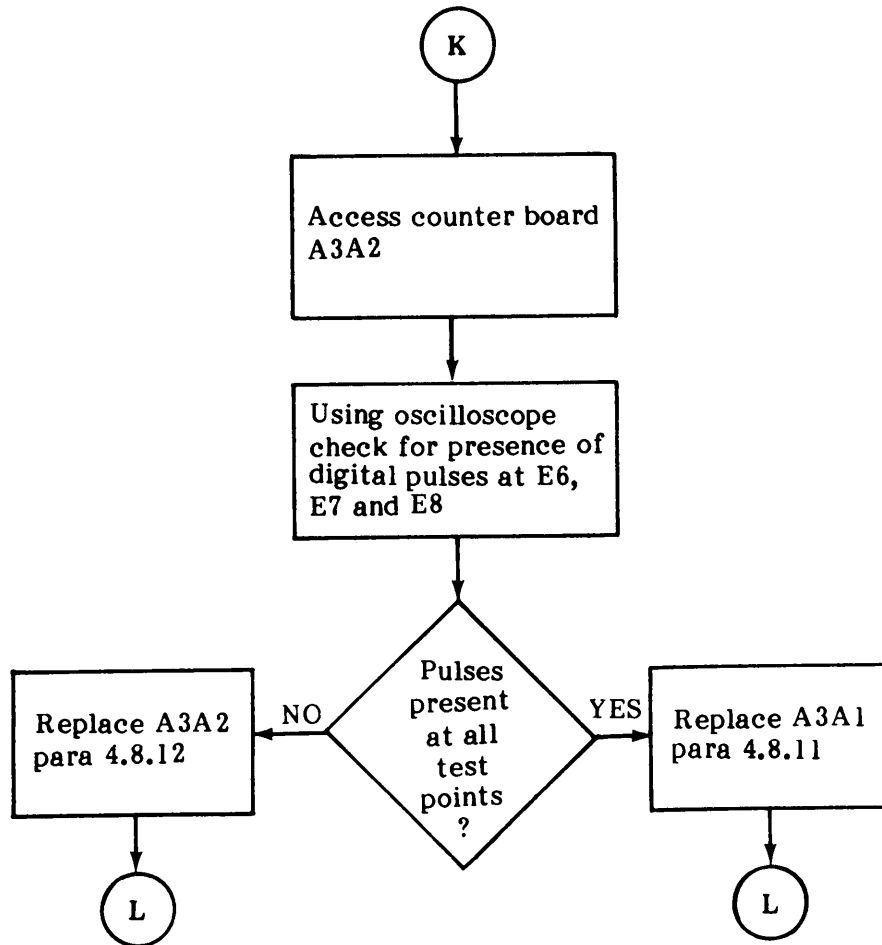


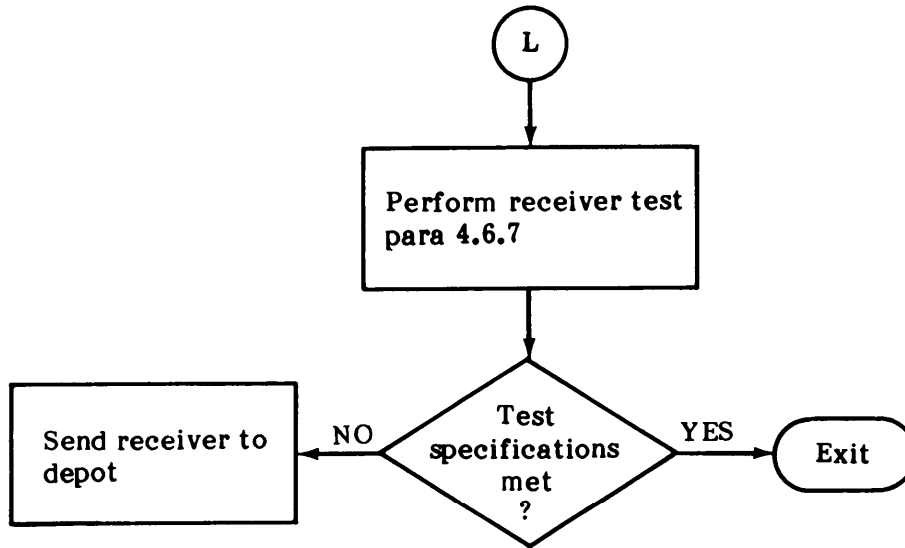












FREQUENCY MHz DISPLAY THAT HAS UNSTABLE DIGITS

INITIAL SETUP

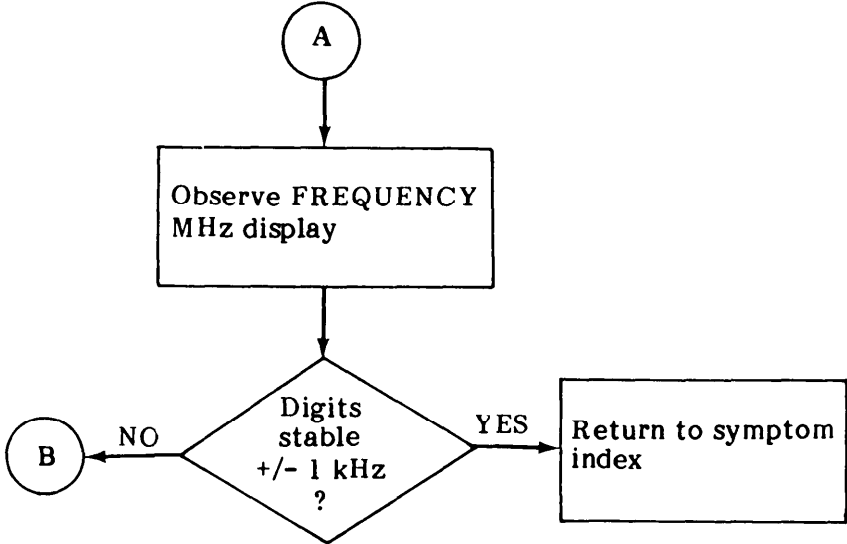
| | |
|--|--|
| <u>Test Equipment</u> | |
| Multimeter | AN/PSM-45 |
| Test Lead Set | Simpson 00577 |
| Signal Generator | SG-1112(V) I/U w/options 001, 002 and 003 |
| Cable, RF, 50 ohms, 4', BNC-BNC | HP 10503A |
| RF Voltmeter | Boonton 92C |
| High Frequency Probe | Boonton 91-12F |
| 50 ohm Adapter | Boonton 91-8B |
| Power Supply | PP-6547/U |
| <u>Tools</u> | |
| No. 1 Phillips Screwdriver | 5120-00-240-8716 |
| <u>Replacement Parts</u> | |
| DC-DC Converter (A6) | 791794 |
| Tuner (A2) | TN-584/GRR-8(V) |
| Cable (A3W1) | 17300-148-8 |
| Cable (A3W2) | 17300-148-9 |
| <u>Equipment Condition</u> | |
| POWER switch (S7) set to ON | |
| BAND SELECT switch (S8) set to HIGH | |
| Receiver tuned to 150 MHz | |
| Receiver cover removed | |
| Power supply set to 24 Vdc | |
| Power supply connected to J5 | |
| WJ-9121 [TN-584/GRR8(V)] Tuner installed | |

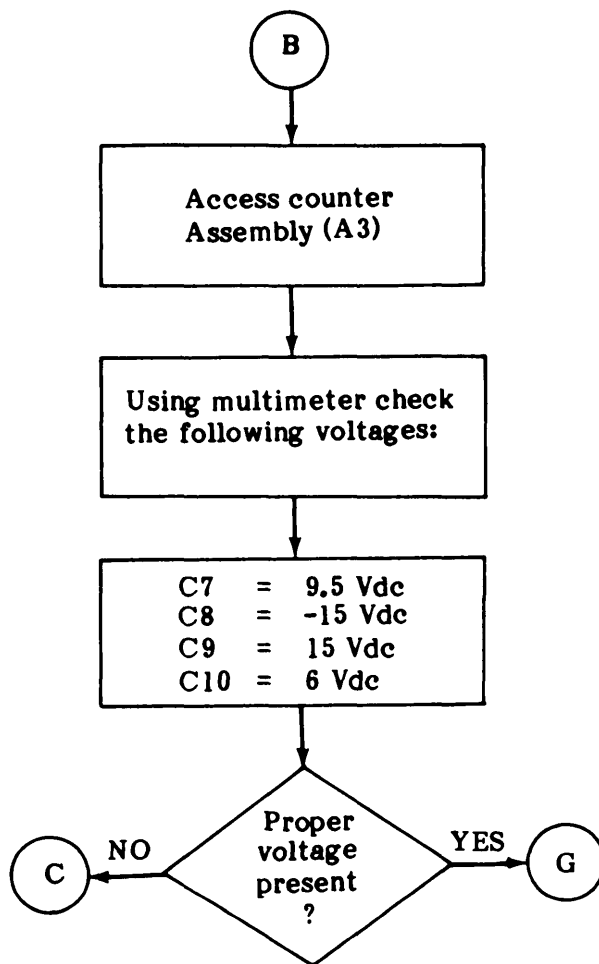
NOTE

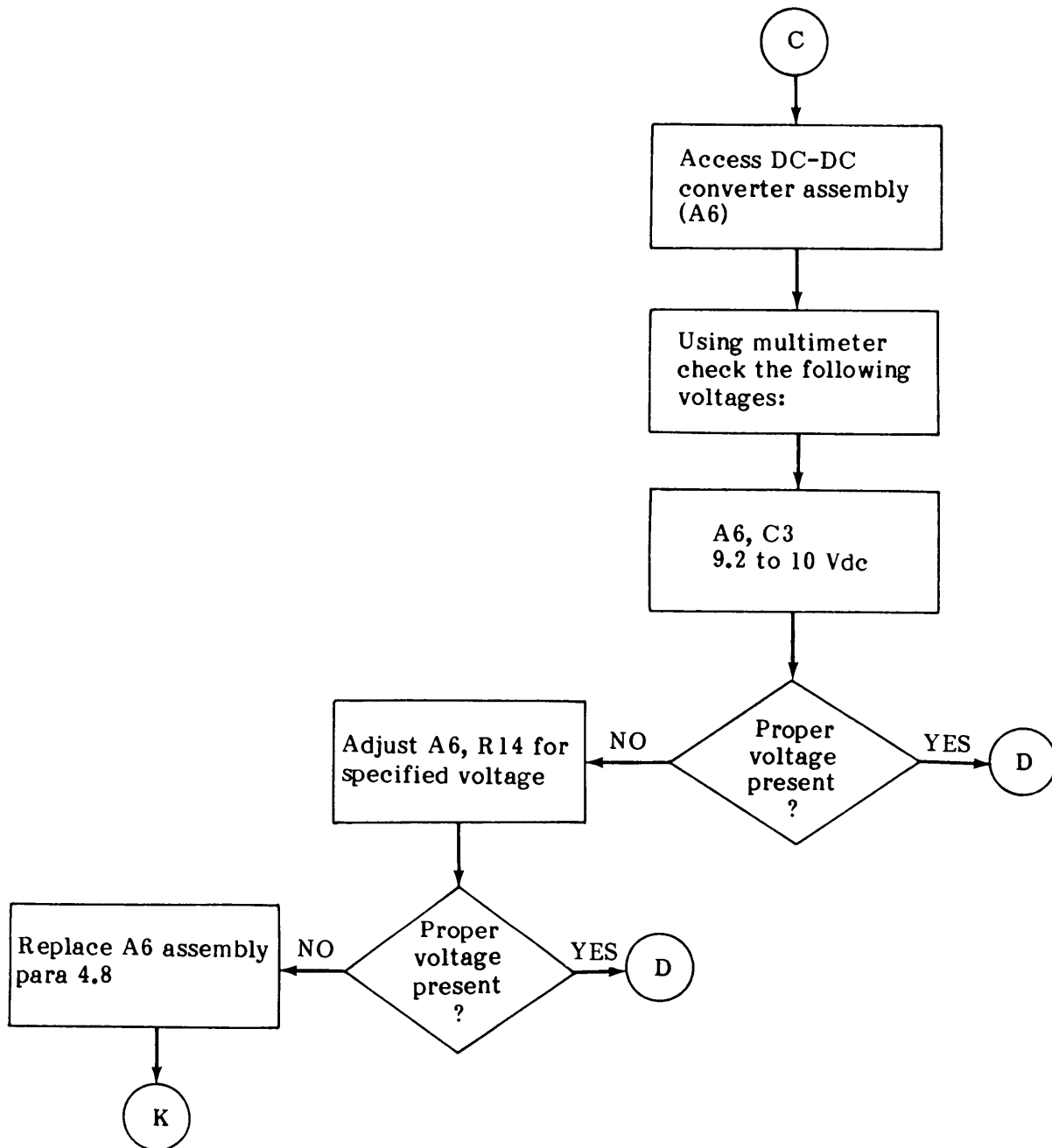
Level readings given reflect the use of the Boonton 91-8B 50 OHM adapter for all cable and connector measurements and the use of the Boonton 91-12F probe with tip at all circuit board measurements.

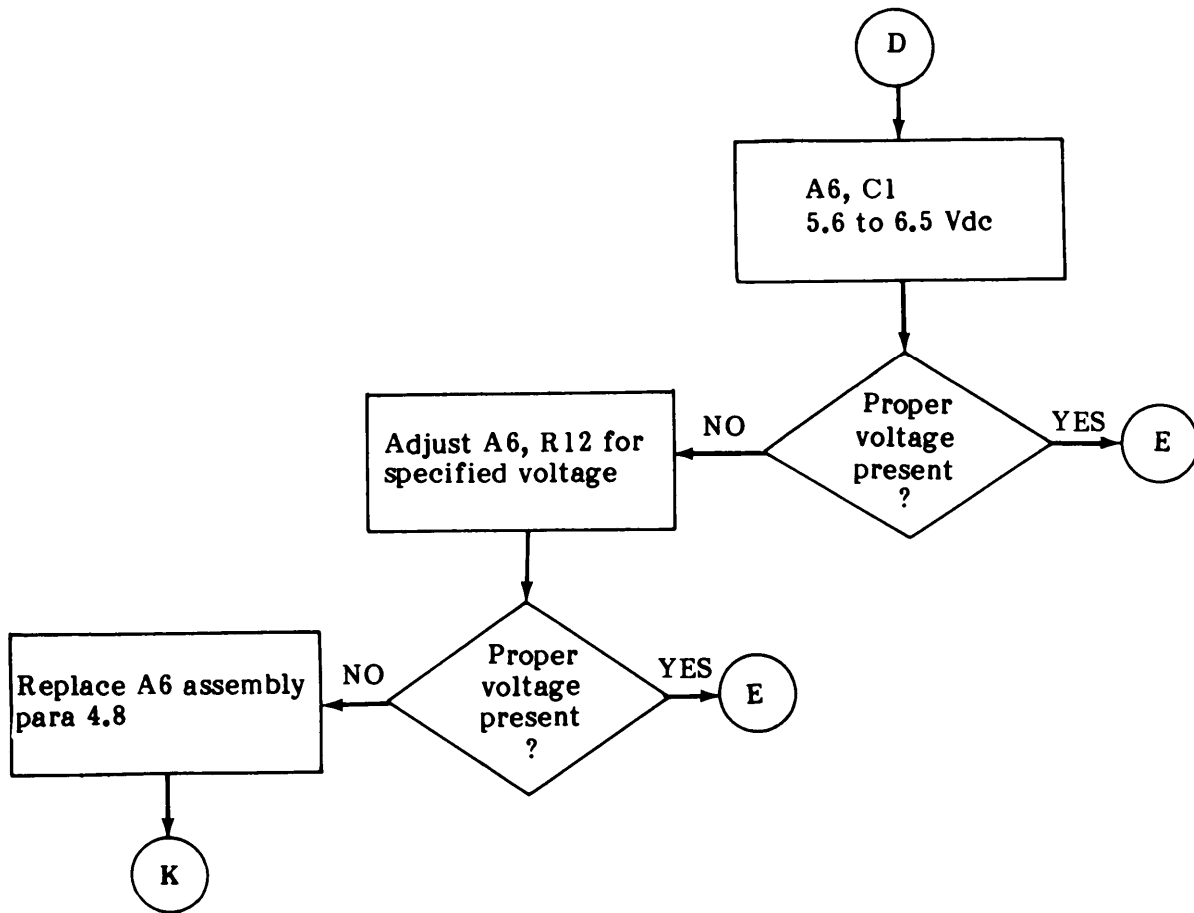
Minimum of 30 minutes warm-up time is required prior to starting troubleshooting procedures

Courtesy of <http://BlackRadios.terryo.org>









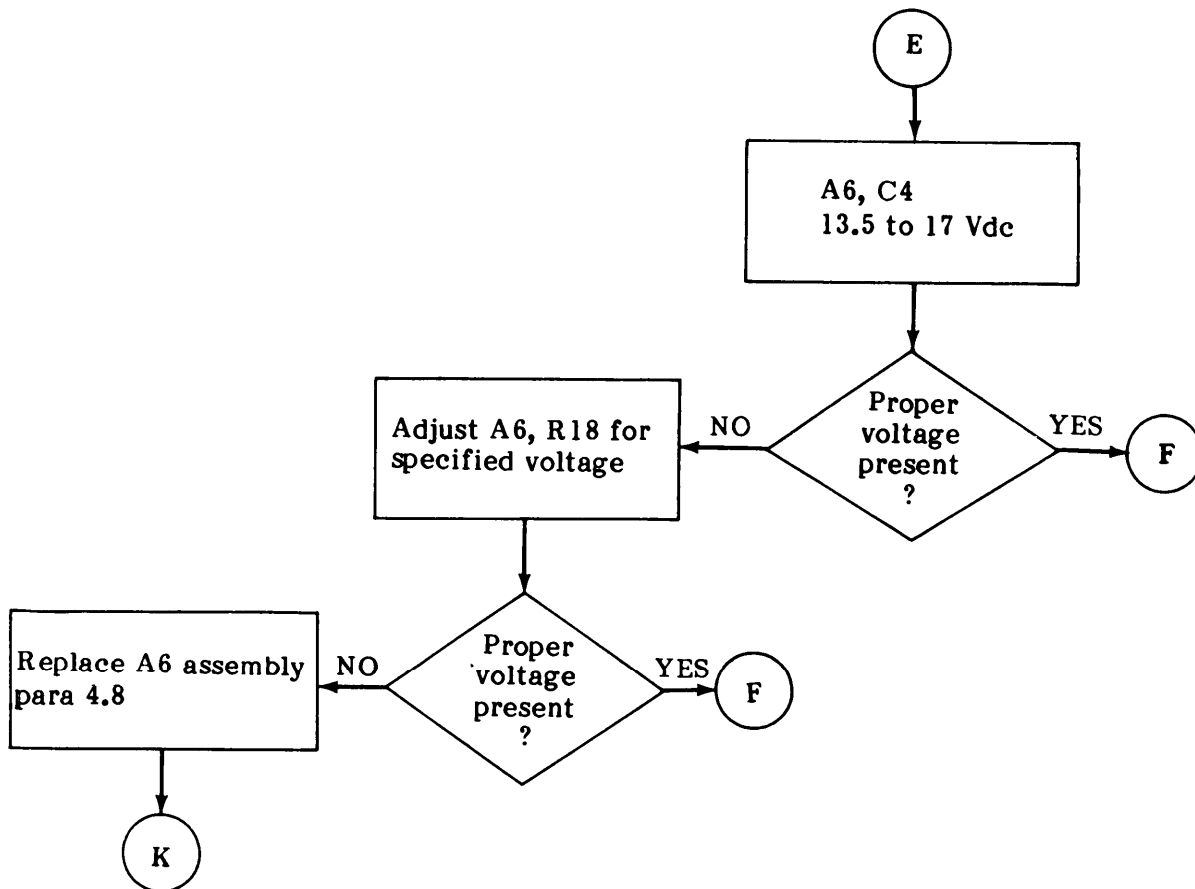
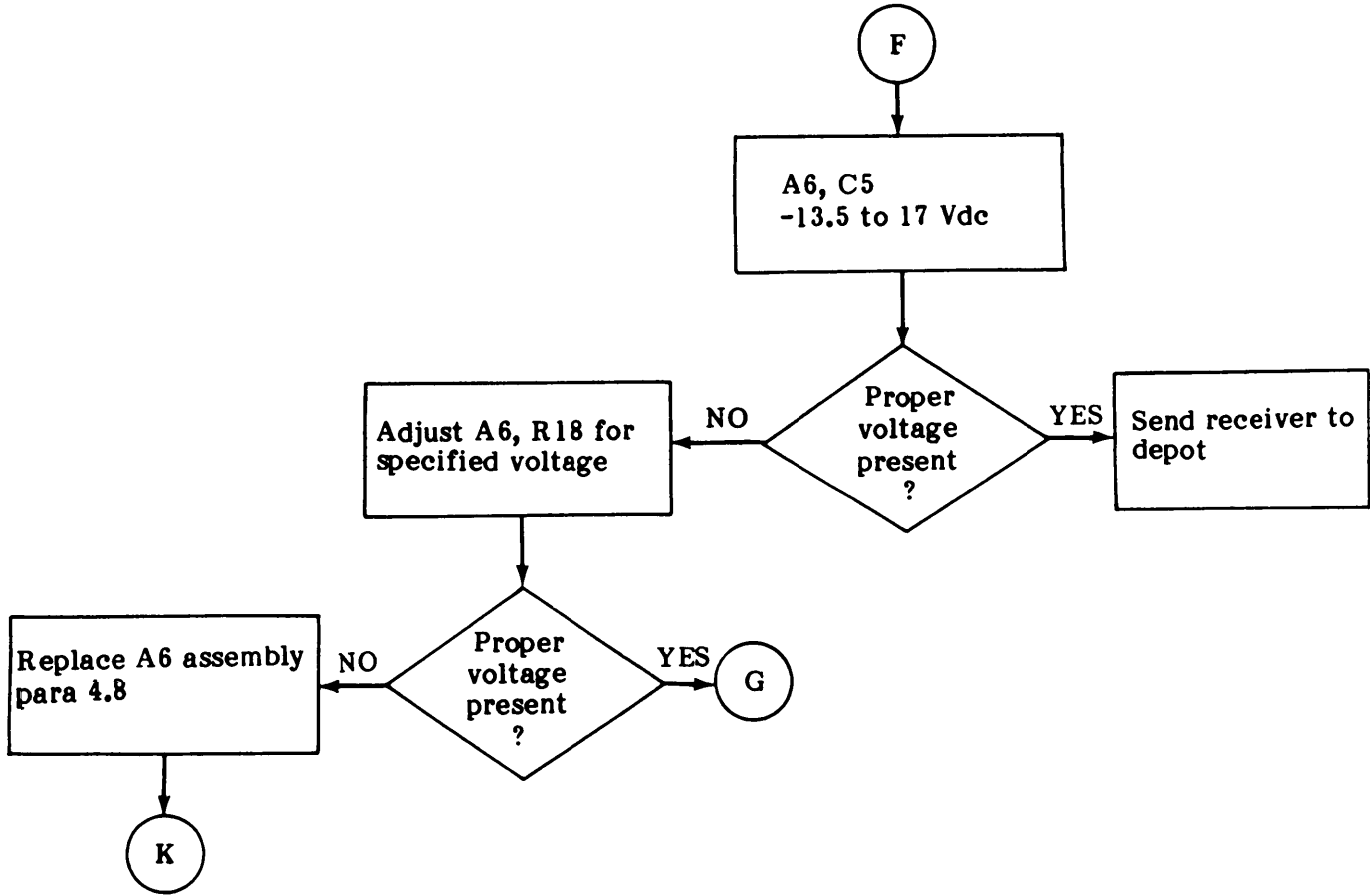
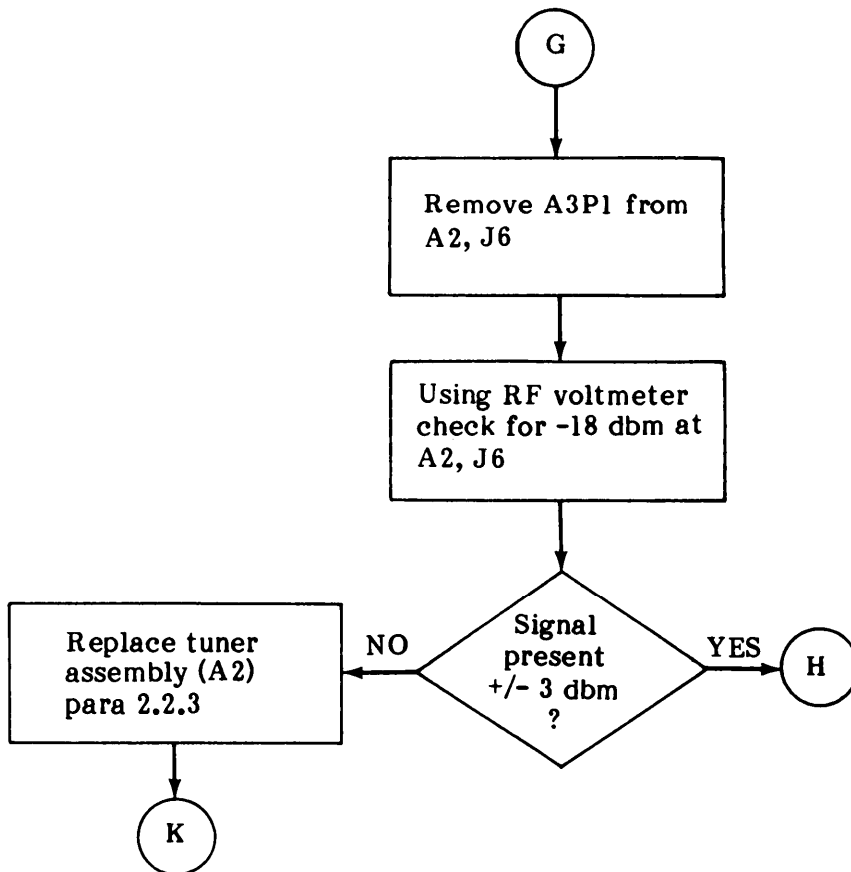
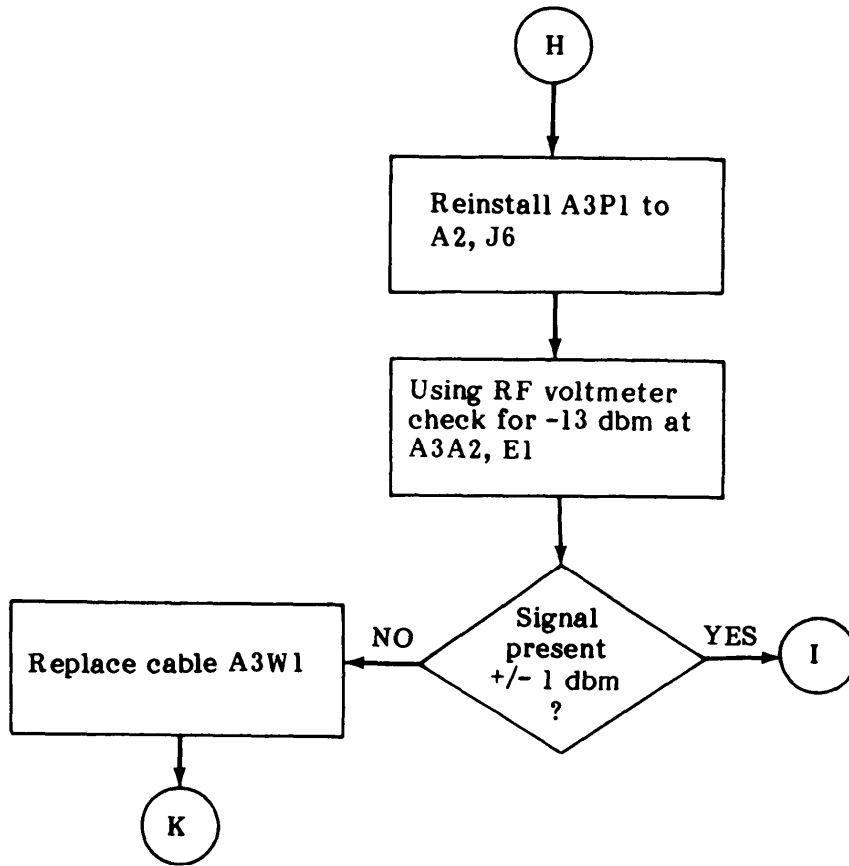
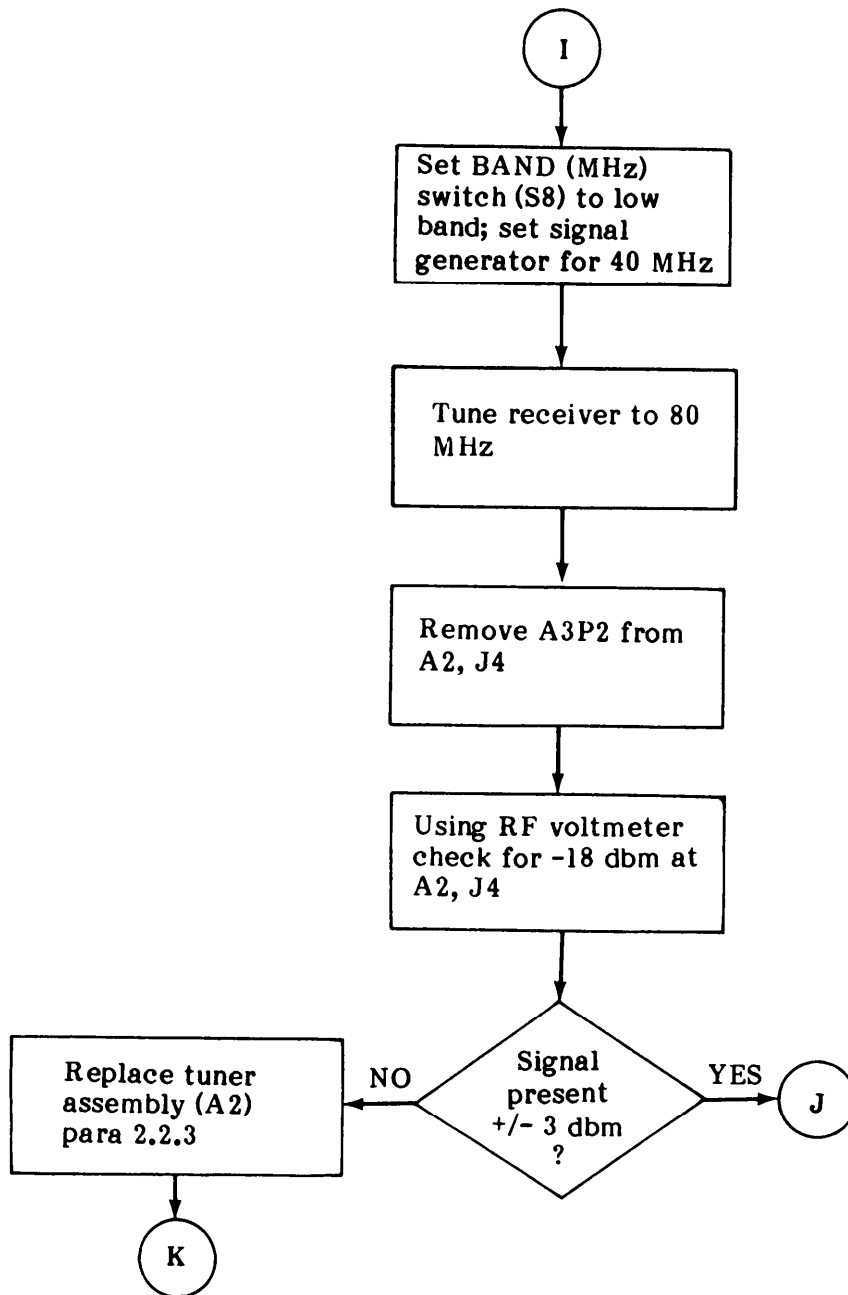


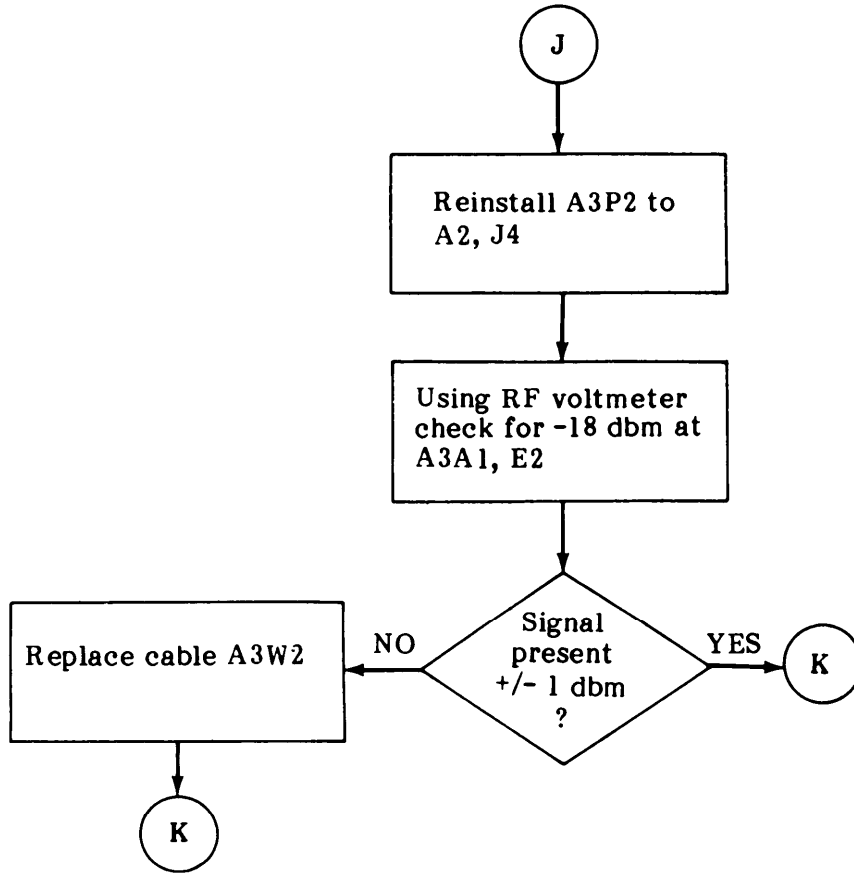
TABLE 4-1

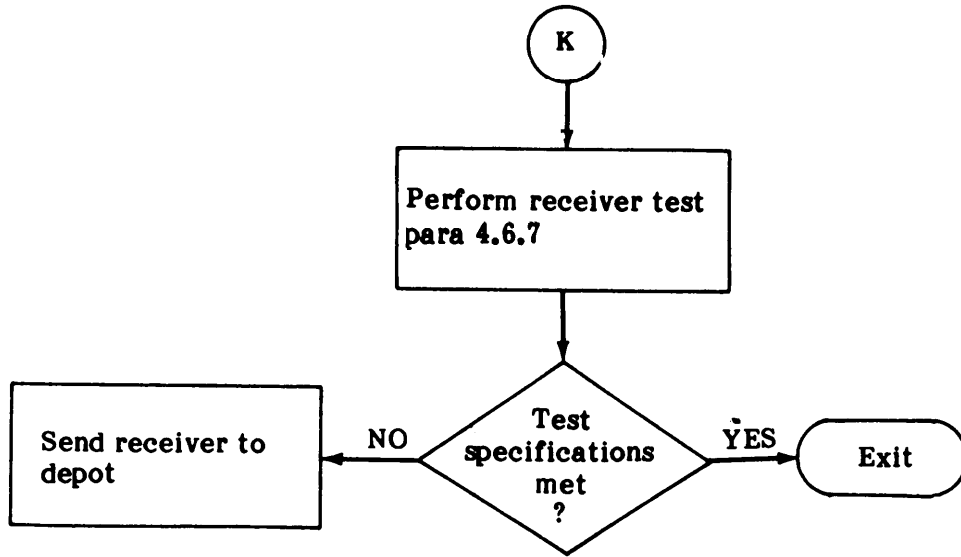












Courtesy of <http://BlackRadios.terryo.org>

Table 4-2. WJ-8640-1 Typical Transistor Voltages*

| Designation | Type | E/S | B/G | C/D | |
|-------------|---------|-----------|--------|-----------|----------|
| A4A1Q1 | 2N2857 | 0.92 | 1.68 | 7.32 | |
| A4A1Q2 | U320 | 3.42 | 0.0 | 6.60 | |
| A4A2Q1 | U1899E | 0.0 | -15.0 | 6.0 | |
| A4A2Q2 | U1899E | 0.0 | -15.0 | 6.0 | |
| A4A2Q3 | U1899E | 6.0 | 0.0 | 6.0 | |
| A4A3Q1 | 2N2857 | 0.0 | 0.0 | 8.60 | |
| A4A3Q2 | 2N2857 | 0.0 | 0.0 | 8.60 | |
| A4A3Q3 | 2N2857 | 0.95 | 1.70 | 8.60 | |
| A4A5Q1 | 2N2857 | 0.91 | 1.56 | 8.31 | |
| A4A6Q1 | 2N2857 | 0.47 | 1.25 | 5.22 | |
| A4A6Q2 | 2N3251 | 0.71 | 0.05 | -14.48 | |
| A4A6Q3 | 2N2222A | 0.13 | 0.63 | 14.27 | |
| A4A6Q4 | 2N2857 | 0.94 | 1.67 | 6.25 | |
| A4A6Q5 | 2N2857 | 0.52 | 1.28 | 5.21 | |
| A4A7Q1 | 2N2857 | 2.16 | 2.48 | 7.92 | SSB Mode |
| A4A7Q2 | 2N2857 | 2.07 | 1.27 | 8.11 | |
| A4A8Q1 | 2N2857 | 0.91 | 1.56 | 8.31 | |
| A5Q2 | 2N2222A | 0.59 | 0.07 | 7.50 | |
| A5Q3 | 2N2222A | 6.90 | 7.49 | 9.21 | |
| A5Q4 | 2N2222A | -13.24 | -12.57 | 0.46 | |
| A5Q5 | 2N2222A | 0.77 | 1.42 | 4.59 | |
| A6Q1 | 2N3054 | 9.5 | 10.2 | 11.0-15.0 | |
| A6Q2 | 2N3054 | 6.0 | 6.7 | 11.0-15.0 | |
| A6A1Q1 | 2N3251 | 11.0-15.0 | ** | 10.2 | |
| A6A1Q2 | 2N3251 | 11.0-15.0 | ** | 6.7 | |
| A6A1Q3 | 2N2270 | 0.0 | 0.70 | 9.5 | |
| A6A1Q4 | 2N2270 | 0.0 | 0.70 | 9.5 | |
| A7Q1 | 2N2857 | 1.83 | 2.52 | 5.86 | |
| A7Q2 | 2N2857 | 1.81 | 2.55 | 5.88 | |
| A7Q3 | 2N2857 | 2.04 | 2.74 | 6.47 | FM Mode |
| A7Q4 | 2N2857 | 2.22 | 2.97 | 9.05 | |
| A7Q5 | 2N3251 | 0.55 | 0.04 | -13.99 | |
| A7Q6 | 2N2222A | 0.04 | 0.55 | 8.85 | |
| A8Q1 | U1899E | -0.64 | -14.20 | -10.708 | |
| A8Q2 | U1899E | 0.0 | 1.72 | 1.72 | |
| A8Q3 | 2N930 | 0.52 | 1.07 | 11.21 | |
| A8Q4 | 2N3251 | 11.86 | 11.21 | 5.34 | |
| A8Q5 | 2N2222A | 4.69 | 5.33 | 12.32 | |
| A8Q6 | 2N2907 | 4.64 | 3.99 | 0.0 | |

* Equipment Setting: AM mode (unless otherwise noted), High Band, 10kHz BW, RF Gain Full CW and Squelch Full CW.

** Voltage dependent on battery voltage level.

Table 4-3. Typical Integrated Circuit Pin Voltages*

| TYPE | 1 | 2 | 3 | 4 | 5 | 6 | 7 | 8 | 9 | 10 | 11 | 12 | 13 | 14 |
|---------|-------|-------|-------|--------|-------|--------|--------|-----|-----|-----|-----|-------|-----|--------|
| A4A7U1 | | | | | | | | | | | | | | |
| MC1596 | -10.4 | -11.1 | -11.1 | -10.4 | -12.9 | 4.47 | 0.0 | 0.0 | 0.0 | 0.0 | 0.0 | +4.53 | 0.0 | -14.19 |
| A4A7U2 | | | | | | | | | | | | | | |
| μA741 | - | 0.0 | 0.0 | -14.3 | - | 0.01 | +8.12 | - | | | | | | |
| A5U1 | | | | | | | | | | | | | | |
| μA741 | - | 0.46 | 0.46 | -14.3 | - | 0.93 | +13.95 | - | | | | | | |
| A5U2 | | | | | | | | | | | | | | |
| μA741 | - | 0.06 | 0.06 | -14.4 | - | +0.19 | +13.96 | - | | | | | | |
| A5U3 | | | | | | | | | | | | | | |
| μA741 | - | 0.0 | 0.58 | -14.4 | - | +13.15 | +13.96 | - | | | | | | |
| A6A1U1 | | | | | | | | | | | | | | |
| μA741 | - | 6.8 | 6.8 | 0.0 | - | * | * | - | | | | | | |
| A6A1U2 | | | | | | | | | | | | | | |
| μA741 | - | 3.4 | 3.4 | 0.0 | - | ** | ** | - | | | | | | |
| A6A1U4 | | | | | | | | | | | | | | |
| μA741 | - | 6.8 | 6.8 | 0.0 | - | ** | ** | - | | | | | | |
| A8U1 | | | | | | | | | | | | | | |
| μA741HM | - | -0.64 | -0.64 | -13.83 | - | -10.68 | +13.69 | - | | | | | | |
| A8U2 | | | | | | | | | | | | | | |
| μA741HM | - | -0.01 | 0.0 | -13.83 | - | -0.07 | +13.69 | - | | | | | | |

* Equipment setting: AM mode (unless otherwise noted), High Band, 10 kHz
 BW, RF Gain full CCW and squelch Full CW.
 ** * Voltage dependent on battery voltage level.

SECTION V

REPLACEMENT PARTS LIST

5.1 UNIT NUMBERING METHOD

The unit numbering method of assigning reference designations (electrical symbol numbers) has been used to identify assemblies, subassemblies (and modules) and parts. An example of the unit method follows:

| <u>Subassembly Designation</u> | <u>A1</u> | <u>RI</u> | <u>Class and No. of Item</u> |
|---------------------------------|-----------|-----------|--|
| Identify from right to left as: | | | First (1) resistor (R) of first (1) subassembly (A) |

As shown on the main chassis schematic, components which are an integral part of the main chassis have no subassembly designation.

5.2 REFERENCE DESIGNATION PREFIX

Partial reference designations have been used on the equipment and on the illustrations in this manual. The partial reference designations consist of the class letter (s) and identifying item number. The complete reference designations may be obtained by placing the proper prefix before the partial reference designations. Reference Designation Prefixes are provided on drawings and illustrations in parenthesis within the figure titles.

5.3 LIST OF MANUFACTURERS

| <u>Mfr. Code</u> | <u>Name and Address</u> | <u>Mfr. Code</u> | <u>Name and Address</u> |
|----------------------|---|----------------------|--|
| 00815 | Northern Engrg. Laboratories, Inc. 357 Beloit Burlington, WI 53105 | 02114 | Ferrocube Corp. P. o. Box 359 Mt. Marion Road Saugerties, N. Y. 12477 |
| 01121 | Allen-Bradley Company 1201 South 2nd Street Milwaukee, WI 53204 | 02289 | Hi-G, Incorporated 580 Spring Street Windsor, CT 06096 |
| 01295 | Texas Instruments, Inc. Semiconductor-Components Div. 13500 North Central Expressway Dallas, Texas 75231 | 02735 | RCA Corporation Solid State Division Route 202 Somerville, MI 48066 |

REPLACEMENT PARTS LIST

TM 11-5895-1227-14-1

| <u>Mfr. Code</u> | <u>Name and Address</u> | <u>Mfr. Code</u> | <u>Name and Address</u> |
|----------------------|---|----------------------|--|
| 04013 | Tarus Corporation 1 Academy Hill Lambertville, NJ 08530 | 19505 | Applied Engineering Products Co. Division of Samarius, Inc. 300 Seymour Avenue Derby, CT 06418 |
| 04713 | Motorola, Incorporated Semiconductor Products Division 5005 East McDowell Road Phoenix, AZ 80058 | 24539 | Avantek, Inc. 3175 Bowers Avenue Santa Clara, CA 95051 |
| 05820 | Wakefield Engineering, Inc. Audubon Road Wakefield, Mass 01880 | 25350 | Donald Bruce and Co. 3600 N. Talman Street Chicago, IL 60618 |
| 07263 | Fairchild Camera & Instr., Corp. Semiconductor Division 464 Ellis Street Mountain View, CA 94040 | 27956 | Relcom 3333 Hillview Avenue Palo Alto, CA 94304 |
| 11532 | Teledyne Relays 3155 W. El Segundo Blvd. Hawthorne, CA 90250 | 28480 | Hewlett- Packard Co. Corporate Headquarters 1501 Page Mill Road Palo Alto, CA 94304 |
| 14632 | Watkins-Johnson Company 700 Quince Orchard Road Gaithersburg, MD. 20878 | 33095 | Spectrum Control, Inc. 152 E. Main Street Fairview, PA 16415 |
| 16237 | Connector Corp. 6025 N. Keystone Avenue Chicago, IL 60646 | 56289 | Sprague Electric Co. Marshall Street North Adams, MA 01247 |
| 17856 | Siliconix, Inc. 2201 Laurelwood Road Santa Clara, CA 95050 | 71279 | Cambridge Therm ionic Corp. 445 Concord Avenue Cambridge, MA 02138 |
| 18324 | Signetics Corporation 811 Ease Arques Avenue Sunnyvale, CA 94086 | 71400 | Bussman Manufacturing Division of McGraw-Edison Co. 2536 W. University Street St. Louis, MO 63107 |

| <u>Mfr. Code</u> | <u>Name and Address</u> | <u>Mfr. Code</u> | <u>Name and Address</u> |
|----------------------|---|----------------------|--|
| 71785 | TRW Electronic Components Cinch Connector Operations 1501 Morse Avenue Elk Grove Village, IL 60007 | 80031 | Electra-Midland Corp. MEPCO Division 22 Columbia Road Morristown, NJ 07960 |
| 72136 | Electro Motive Mfg. Co., Inc. South Park & John Streets Willimantic, CT 06226 | 80058 | Joint Electronic Type Designation System |
| 72653 | GC Electronics Company Div. of Hydrometals, Inc. 400 S. Wyman Street Rockford, IL 61101 | 80131 | Electronic Industries Association 2001 Eye Street, N.W. Washington, D.C. 20006 |
| 72982 | Erie Tech. Products, Inc 644 West 12th Street Erie, PA 16512 | 81030 | International Instruments, Inc. Div. Sigma Instruments, Inc. 88 Marsh Hill Road Orange, CT 06447 |
| 73138 | Beckman Instr., Inc. Helipot Division 2500 Harbor Blvd. Fullerton, California 92634 | 81073 | Grayhill Incorporated 561 Hillgrove Avenue LaGrange, IL 60525 |
| 73899 | JFD Electronics Co. 15th at 62nd Street Brooklyn, NY 11219 | 81312 | Winchester Electronics Div. Litton Industries, Incorp. Main Street & Hillside Avenue Oakville, CT 06779 |
| 74306 | Piezo Crystal Co. 100K Street Carlisle, PA 17013 | 81349 | Military Specifications |
| | | 81350 | Joint Army-Navy Specifications |
| 75042 | TRW Electronic Components IRC Fixed Resistors 401 North Broad Street Philadelphia, PA 19108 | 83740 | Union Carbide Corporation Consumers Product Division 270 Park Avenue New York, NY 10017 |
| 75915 | Littlefuse, Inc. 800 E. Northwest Highway Des Plaines, IL 60016 | 84792 | Happner Manufacturing P.O. Box Q Round Lake, Illinois 60073 |

| <u>Mfr. Code</u> | <u>Name and Address</u> | <u>Mfr. Code</u> | <u>Name and Address</u> |
|----------------------|--|----------------------|---|
| 91418 | Radio Materials Company 4242 West Bryn Mawr Avenue Chicago, IL 60646 | 94144 | Raytheon Company Components Division Industrial Components Operation 465 Centre Street Quincy, MA 02169 |
| 91637 | Dale Electronics, Inc. P.O. Box 609 Columbus, NE 68601 | 95146 | Alco Electronics Prod. Inc. P.O. Box 1348 Lawrence, MA 01842 |
| 92825 | Whitso Incorporated 9330 Bryon Street Schiller Park, IL 60176 | 95712 | Bendix Corporation The Electrical Components Div. Microwave Devices Plant Hurricane Road Franklin, IN 46131 |
| 93332 | Sylvania Electric Products, Inc. Semiconductor Products Division 100 Sylvan Road Woburn, MA 01801 | 97539 | APM-Hexseal Corporation 44 Honeck Street Englewood, NJ 07631 |
| 93958 | Republic Electronics Corp. 176 East 7th Street Paterson, NJ 07524 | 99800 | American Precision Industries Delevan Electronics Division 270 Quaker Road East Aurora, NY 14052 |

5.4 PARTS LIST

The parts list which follows contains all electrical parts used in the equipment and certain mechanical parts which are subject to unusual wear or damage. When ordering replacement parts from Watkins-Johnson Company, specify the type and serial number of the equipment and the reference designation and description of each part ordered. The list of manufacturers provided in paragraph 5.3 and the manufacturer's part number for components are included as a guide to the user of the equipment in the field. These parts may not necessarily agree with the parts installed in the equipment; however, the parts specified in this list will provide satisfactory operation of the equipment. Replacement parts may be obtained from any manufacturer as long as the physical and electrical parameters of the part selected agree with the original indicated part. In the case of components defined by a military or industrial specification, a vendor which can provide the necessary component is suggested as a convenience to the user.

NOTE

As improved semiconductors become available, it is the policy of Watkins-Johnson to incorporate them in proprietary products. For this reason some transistors, diodes and integrated circuits installed in the equipment may not agree with those specified in the parts list and schematic diagrams of this manual. However, the semiconductors designated in the manual may be substituted in every case with satisfactory results.

Courtesy of <http://BlackRadios.terryo.org>

TYPE WJ-8640-1 VHF PORTABLE RECEIVER MAIN CHASSIS

| REF DESIG | DESCRIPTION | QTY PER ASSY | MANUFACTURER'S PART NO. | MFR. CODE | RECM VENDOR |
|-----------|--|--------------|-------------------------|-----------|-------------|
| A1 | Antenna Switch Assembly | 1 | 791783 | 14632 | |
| A2 | Tuner Assembly | 1 | See Chart | 14632 | |
| | Tuner Assembly and Frequency Range Chart | | | | |
| | Frequency Range (MHz) | | Tuner Assembly | | |
| | 0.5 - 30 | | WJ-9120 | | |
| | 20 - 250 | | WJ-9121 | | |
| | 20 - 80 | | WJ-9122 | | |
| | 80 - 250 | | WJ-9123 | | |
| | 250 - 500 | | WJ-9124 | | |
| | NOTE: Above Tuner Assemblies are Documented in Separate Manuals. | | | | |
| A3 | Counter Assembly | 1 | 791806 | 14632 | |
| A4 | IF Demodulator Assembly | 1 | 791800-1 | 14632 | |
| A5 | AGC Squelch | 1 | 791817 | 14632 | |
| A6 | DC-DC Converter | 1 | 791794 | 14632 | |
| A7 | FM Discriminator Assembly | 1 | 791784 | 14632 | |
| A8 | Audio/Record Amplifier | 1 | 7464 | 14632 | |
| A9 | Battery Pack Assembly | 1 | 791795-1 | 14632 | |
| A10 | Front Cover/Speaker Assembly | 1 | 791809-1 | 14632 | |
| C1 | Capacitor, Mica, Dipped: 620 pF, 5%, 300 V | 1 | DM15-621J | 72136 | |
| C2 | Capacitor, Mica, Dipped: 130 pF, 2%, 500 V | 1 | CM05FD131G03 | 81349 | 72136 |
| C3 | Capacitor, Mica, Dipped: 33 pF, 2%, 500 V | 1 | DM05ED330G03 | 81349 | 72136 |
| C4 | Capacitor, Ceramic, Feedthru: 33 pF, 10%, 500 V | 1 | 54-794-001-3301 | 33095 | |
| C5 | Capacitor, Ceramic, Feedthru: 330 pF, 10%, 500 V | 1 | 54-794-001-3311 | 33095 | |
| C6 | Capacitor, Ceramic, Feedthru: 470 pF, 20%, 500 V | 6 | 54-794-009-471M | 33095 | |
| C7 | Same as C6 | | | | |
| C8 | Same as C6 | | | | |
| C9 | Same as C6 | | | | |
| C10 | Capacitor, Electrolytic, Tantalum: 220 μF, 20%, 10V | 3 | 196D227X0010TE4 | 56289 | |
| C11 | Same as C10 | | | | |
| C12 | Same as C10 | | | | |
| C13 | Capacitor, Electrolytic, Tantalum: 1 μF, 20%, 35 V | 2 | 196D105X0035HE3 | 56289 | |
| C14 | Same as C13 | | | | |
| C15 | Same as C6 | | | | |
| C16 | Same as C6 | | | | |
| CR1 | Diode | 1 | 5082-4860 | 28480 | |
| CR2 | Diode | 4 | 1N4003 | 80131 | 04713 |
| CR3 | Same as CR2 | | | | |
| CR4 | Diode | 1 | 1N462A | 80131 | 93332 |

FIGURE 5-1
FIGURE 5-2

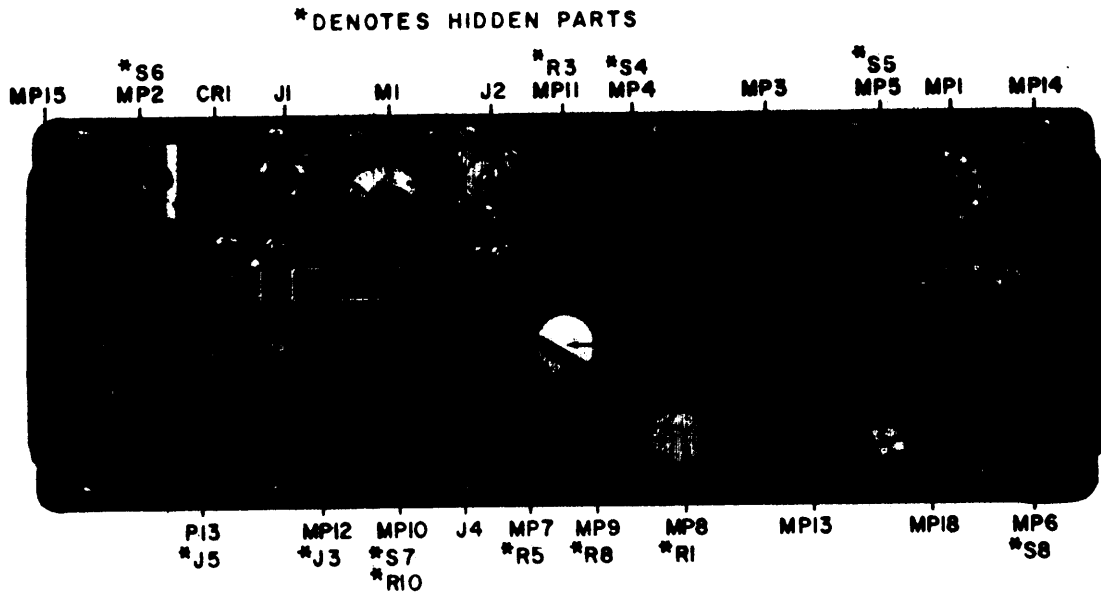


Figure 5-1. WJ-8640-1 VHF Portable Receiver, Front View,
Location of Components

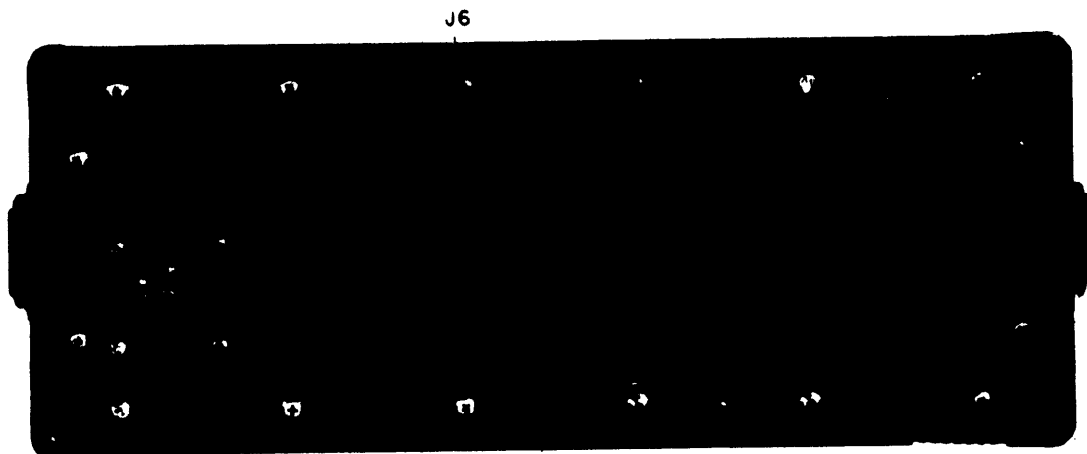


Figure 5-2. WJ-8640-1 VHF Portable Receiver, Rear View,
Location of Components

MAIN CHASSIS

| REF DESIG | DESCRIPTION | QTY. PER ASSY. | MANUFACTURER'S PART NO. | MFR. CODE | RECM. VENDOR |
|---------------------|-------------------------------------|----------------------|----------------------------|--------------|-----------------|
| CR5 | Same as CR2 | | | | |
| CR6 | Same as CR2 | | | | |
| F1 | Fuse, Cartridge: 3/4 AMP, Slow-Blow | 1 | MDL3/4 | 71400 | |
| FB1 | Ferrite Bead | 10 | 56-590-65-4A | 02114 | |
| FB2 Thru FB10 | Same as FB1 | | | | |
| J1 | Connector, Receptacle: BNC Series | 2 | 4084-1 | 95712 | |
| J2 | Same as J1 | | | | |
| J3 | Connector, Receptacle: Multipin | 2 | GC283 | 25350 | |
| J4 | Same as J3 | | | | |
| J5 | Connector, Receptacle: Multipin | 1 | U318/U | 25350 | |
| J6 | Connector, Receptacle: Multipin | 1 | GC075 | 25350 | |
| J7 | Connector, Receptacle: SRE Series | 2 | SRE20SNSS | 81312 | |
| J8 | Same as J7 | | | | |
| J9 | Connector, Receptacle: SRE Series | 1 | SRE14SNSS | 81312 | |
| J10 | Connector, Receptacle: SRE Series | 1 | SRE7SNSS | 81312 | |
| K1 | Relay | 1 | 2BK1B113 | 02289 | |
| M1 | Meter, Signal Strength | 1 | MR05W100DCUA | 81030 | |
| MP1 | Control Knob, Round | 1 | 50-2WD-1G | 94144 | |
| MP2 | Push Button Boot | 1 | N5040G | 97539 | |
| MP3 | Window | 2 | 17569-1 | 14632 | |
| MP4 | Control Knob, Pointer | 3 | 50-5-1G | 94144 | |
| MP5 | Same as MP4 | | | | |
| MP6 | Same as MP4 | | | | |
| MP7 | Tactile Knob Bushing Assembly | 1 | 25250-1 | 14632 | |
| MP8 | Tactile Knob Bushing Assembly | 1 | 25250-2 | 14632 | |
| MP9 | Tactile Knob Bushing Assembly | 1 | 25250-3 | 14632 | |
| MP10 | Tactile Knob Bushing Assembly | 1 | 25250-4 | 14632 | |
| MP11 | Tactile Knob Bushing Assembly | 1 | 25250-5 | 14632 | |
| MP12 | Protective Rubber Caps (Dual) | 1 | SM-B-447220 | * | |
| MP13 | Control Knob Spinner | 1 | 18665-1 | 14632 | |
| MP14 | Handle, Modified | 2 | 18685-1 | 14632 | |
| MP15 | Same as MP14 | | | | |
| MP16 | Handle, P.C. Board | 1 | 15689-1 | 14632 | |
| MP17 | Handle, Modification | 1 | 24287-1 | 14632 | |
| MP18 | Same as MP3 | | | | |

* AN/COM Electronics Corp. , N. Hollywood, Calif.

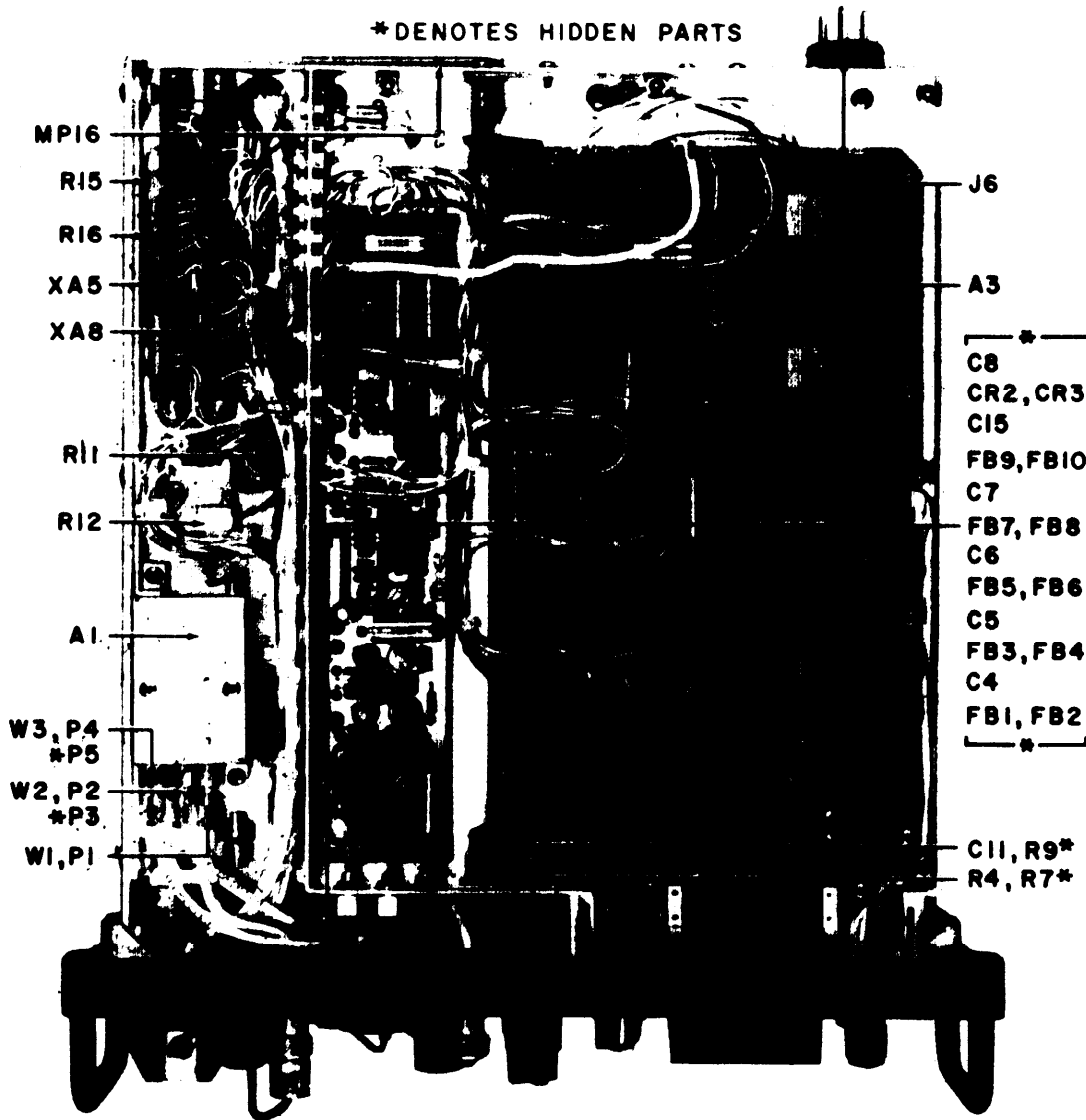


Figure 5-3. WJ-8640-1 VHF Portable Receiver, Top View, Location of Components

MAIN CHASSIS

| REF DESIG | DESCRIPTION | QTY. PER ASSY. | MANUFACTURER'S PART NO. | MFR. CODE | RECM. VENDOR |
|------------------|--|----------------------|----------------------------|--------------|-----------------|
| P1 | Connector, Plug: BNC Series | 7 | UG1465/U | 80058 | 19505 |
| P2 Thru P6 | Same as P1 | | | | |
| P7 | Same as P12 | | | | |
| P8 | Same as P1 | | | | |
| P9 | Same as P12 | | | | |
| P10 | Same as P12 | | | | |
| P11 | Connector, Plug: SMC Series | 1 | UG1466/U | 80058 | 19505 |
| P12 | Connector, Plug: SMB Series | 4 | 202/188 | 19505 | |
| P13 | Connector, Plug: Multipin, Shorting | 1 | U317/U | 25350 | |
| R1 | Resistor, Variable, Composition: 10 k Ω , 10%, 1/2 W | 1 | RV6NAYSD103A | 81349 | |
| R2 | Resistor, Fixed, Film: 22.1 k Ω , 1%, 1/10 W | 3 | RN55C2212F | 81349 | 75042 |
| R3 | Resistor, Variable, Composition: 50 k Ω , 10%, 1/2 W | 2 | RV6NAYSD503A | 81349 | |
| R4 | Same as R2 | | | | |
| R5 | Resistor, Variable, Film: 50 k Ω , (with switch) | 1 | 14M025W50K | 01121 | |
| R6 | Same as R2 | | | | |
| R7 | Resistor, Fixed, Film: 33.2 k Ω , 1%, 1/10 W | 1 | RN55C3322F | 81349 | 75042 |
| R8 | Same as R3 | | | | |
| R9 | Resistor, Fixed, Composition: 4.7 k Ω , 5%, 1/4 W | 1 | RCR07G472JS | 81349 | 01121 |
| R10 | Resistor, Variable, Composition: 50 k Ω , 10%, 1/2 W (with switch) | 1 | WRSIG040S503UA | 01121 | |
| R11 | Resistor, Variable, Composition: 50 k Ω , 10%, 1/2 W | 1 | RV6LAYS503A | 81349 | 01121 |
| R12 | Resistor, Fixed, Wire-Wound: 20 Ω , 1%, 5 W | 1 | RH5-20/OHMF | 91637 | |
| R13 | Resistor, Fixed, Composition: 1 k Ω , 5%, 1/4 W | 2 | RCR07G102JS | 81349 | 01121 |
| R14 | Same as R13 | | | | |
| R15 | Resistor, Fixed, Composition: 10 k Ω , 5%, 1/4 W | 2 | RCR07G103JS | 81349 | 01121 |
| R16 | Same as R15 | | | | |
| S1 | Not Used | | | | |
| S2 | Not Used | | | | |
| S3 | Switch, Snap | | | | Part of R5 |
| S4 | Switch, Rotary | 1 | 9S30-01-4-3N | 81073 | |
| S5 | Switch, Rotary | 1 | 9S30-01-3-4N | 81073 | |
| S6 | Switch, Push Button: SPST | 1 | 30-1 | 81073 | |
| S7 | Switch, Snap | | | | Part of R10 |
| S8 | Switch, Rotary | 1 | 9S30-01-6-2N | 81073 | |
| VR1 | Voltage Regulator: 15 volts | 1 | MC7815CK | 04713 | |

FIGURE 5-4

TM 11-5895-1227-14-1

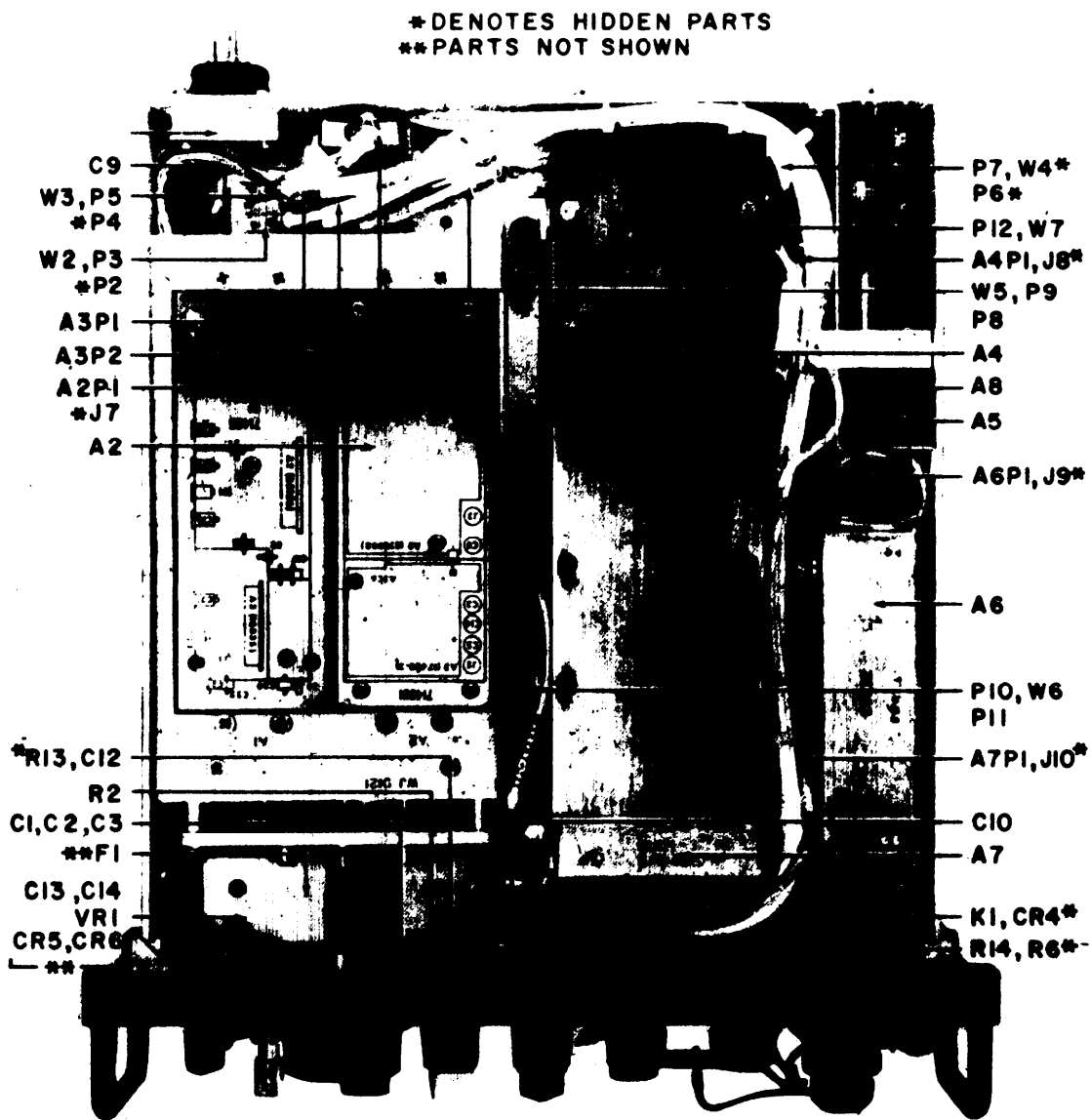


Figure 5-4. WJ-8640-1 VHF Portable Receiver, Bottom View, Location of Components

TM 11-5895-1227-14-1

REPLACEMENT PARTS LIST

| MAIN CHASSIS | | | | | |
|--------------|------------------------|----------------------|----------------------------|--------------|-----------------|
| REF DESIG | DESCRIPTION | QTY. PER ASSY. | MANUFACTURER'S PART NO. | MFR. CODE | RECM. VENDOR |
| W1 | Cable Assembly | 1 | 17300-148-1 | 14632 | |
| W2 | Cable Assembly | 1 | 17300-148-2 | 14632 | |
| W3 | Cable Assembly | 1 | 17300-148-3 | 14632 | |
| W4 | Cable Assembly | 1 | 17300-148-4 | 14632 | |
| W5 | Cable Assembly | 1 | 17300-148-5 | 14632 | |
| W6 | Cable Assembly | 1 | 17300-148-6 | 14632 | |
| W7 | Cable Assembly | 1 | 17300-148-7 | 14632 | |
| XA5 | Connector, P. C. Board | 2 | 250-22-30-170 | 71785 | |
| XA8 | Same as XA5 | | | | |
| XF1 | Fuseholder, Clip | 1 | 357001 | 75915 | |
| AI1 | Extender Board | 1 | 791211-1 | 14632 | |
| AI2 | Extender Board | 1 | 791212 | 14632 | |
| AI3 | No. 4 Allen Wrench | 1 | GGGW0652-050-AF | 81349 | 72653 |
| AI4 | No. 6 Allen Wrench | 1 | GGGW06521/16AF | 81349 | 72653 |
| AI5 | Tool, Alignment | 1 | 5284 | 73899 | |
| AI6 | Antenna | 1 | AT-892/PRC-25 | 26419 | |

5.5.1 TYPE 791783 ANTENNA SWITCH

REF DESIG PREFIX A1

| REF DESIG | DESCRIPTION | QTY. PER ASSY. | MANUFACTURER'S PART NO. | MFR. CODE | RECM. VENDOR |
|-----------|---|----------------|-------------------------|-----------|--------------|
| A1 | Antenna Switch P.C. Assembly | 1 | 270172 | 14632 | |
| C1 | Not Used | | | | |
| C2 | Capacitor, Ceramic, Feedthru: .05 μ F, GMV, 300 V | 1 | 54-785-002-503P | 33095 | |
| J1 | Connector, Receptacle | 3 | 10-0104-002 | 19505 | |
| J2 | Same as J1 | | | | |
| J3 | Same as J1 | | | | |

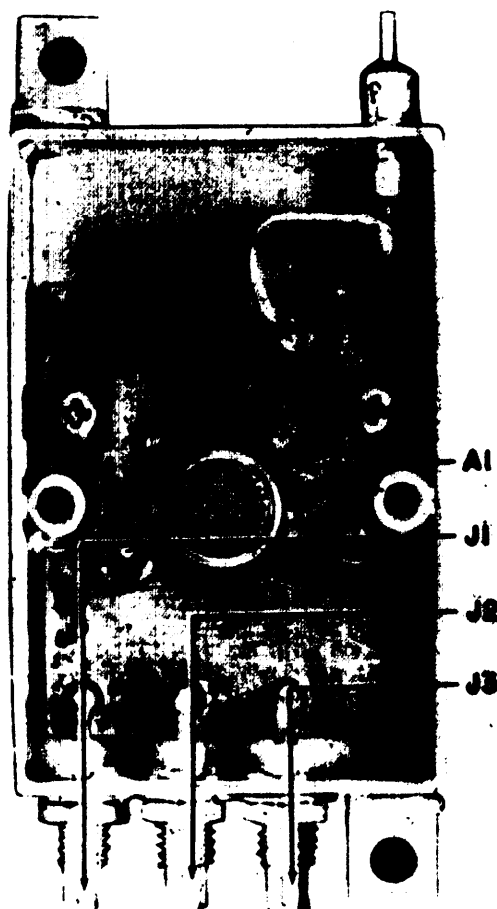


Figure 5-5. Type 791783 Antenna Switch (A1),
Location of Components

TM 11-5895-1227-14-1

REPLACEMENT PARTS LIST

5.5.1.1 TYPE 270172 Antenna Switch P.C. Assembly

REF DESIG PREFIX A1A1

| REF DESIG | DESCRIPTION | QTY. PER ASSY. | MANUFACTURER'S PART NO. | MFR. CODE | RECM. VENDOR |
|--------------|------------------------|----------------------|----------------------------|--------------|-----------------|
| K1 | Relay, DPDT, 12 V Coil | 1 | 712-12 | 11532 | |

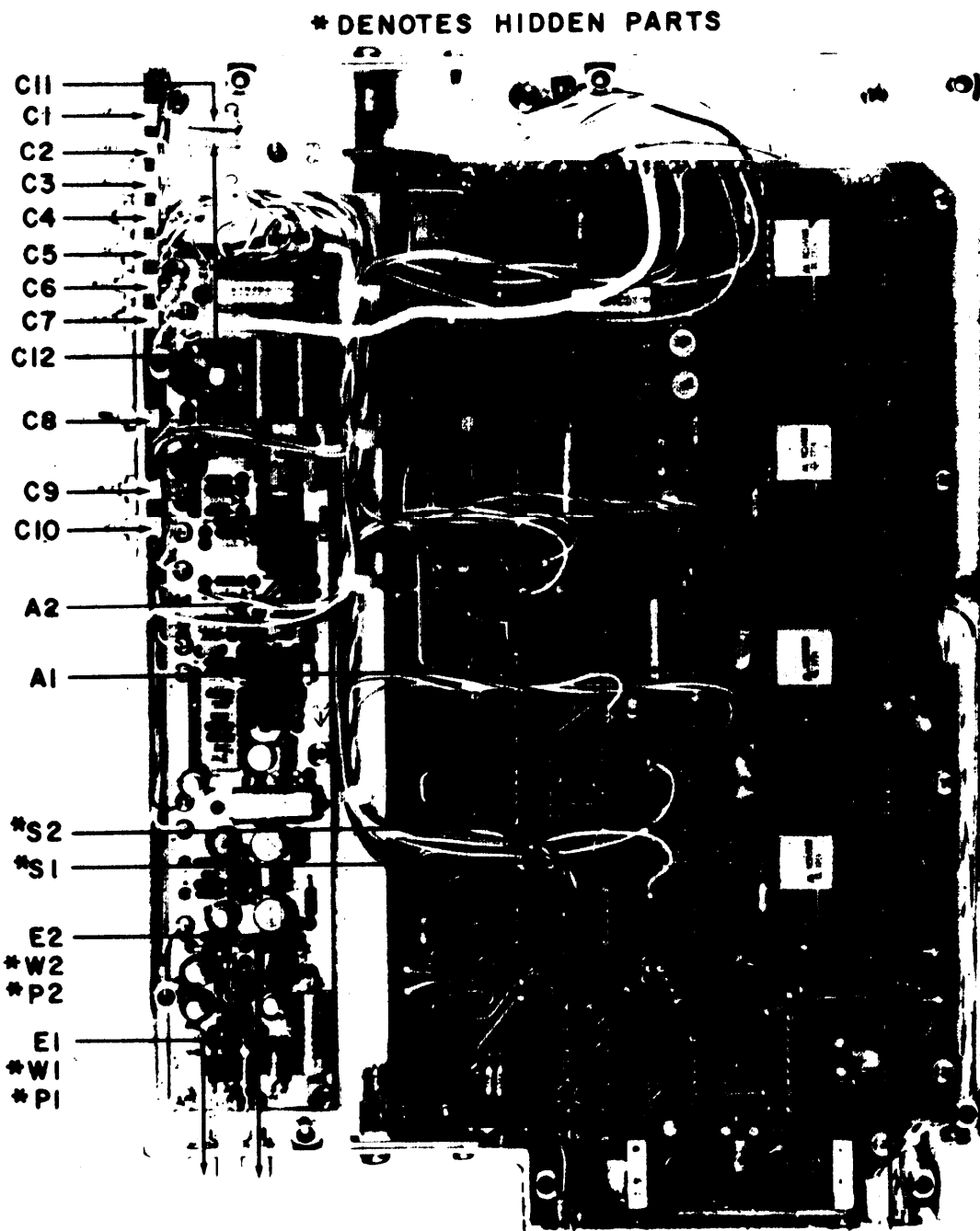


Figure 5-6. Type 791806 Counter Assembly (A3),
Location of Components

TM 11-5895-1227-14-1

REPLACEMENT PARTS LIST

5.5.2 TYPE 791806 COUNTER ASSEMBLY

REF DESIG PREFIX A3

| REF DESIG | DESCRIPTION | QTY PER ASSY | MANUFACTURER'S PART NO. | MFR. CODE | RECM VENDOR |
|--------------------|---|--------------------|----------------------------|--------------|----------------|
| A1 | Counter Board | 1 | 791808 | 14632 | |
| A2 | Wideband Amplifier and First Counter | 1 | 34912 | 14632 | |
| C1 | Capacitor, Ceramic, Feedthru: .05 μ F, GMV, 300 V | 10 | 54-785-005-503P | 33095 | |
| C2 Thru C10 | Same as C1 | | | | |
| C11 Thru C14 | Not Used | | | | |
| C15 | Capacitor, Electrolytic, Tantalum: 4.7 μ F, 10%, 35 V | 2 | CS13BF475K | 81349 | |
| C16 | Same as C15 | | | | |
| E1 | Connector, Terminal | 2 | 144/188 | 19505 | |
| E2 | Same as E1 | | | | |
| E3 | Terminal, Miniature | 1 | 4D4A1 | 92825 | |
| P1 | Connector, Plug: SMC Series | 2 | UG1465/U | 80058 | |
| P2 | Same as P1 | | | | |
| R1 | Resistor, Fixed: 10 k Ω , 5%, 1/4 W | 1 | RCR07G103JS | 81349 | |
| S1 | Switch, Toggle, DPDT | 1 | MTE206N | 95146 | |
| S2 | Switch, Rotary | 1 | 51S30-01-2-65 | 81073 | |
| W1 | Cable Assembly | 1 | 17300-148-8 | 14632 | |
| W2 | Cable Assembly | 1 | 17300-148-9 | 14632 | |

REPLACEMENT PARTS LIST

TM 11-5895-1227-14-1

5.5.2.1 Type 791808 Counter Board

REF DESIG PREFIX A3A1

| REF DESIG | DESCRIPTION | QTY PER ASSY | MANUFACTURER'S PART NO. | MFR. CODE | RECM VENDOR |
|--------------------|---|--------------------|----------------------------|--------------|----------------|
| A1 | Display Board | 1 | 24947-1 | | |
| C1 | Capacitor, Variable, Ceramic: 5-25 pF, 100 V | 1 | 518-000A5-25 | 72982 | |
| C2 | Capacitor, Mica, Dipped: 18 pF, 5%, 500 V | 1 | CM05CD180J03 | 81349 | 72136 |
| C3 | Capacitor, Mica, Dipped: 750 pF, 5%, 300 V | 2 | DM15-751J | 72136 | |
| C4 | Same as C3 | | | | |
| C5 | Capacitor, Ceramic, Disc: 0.1 μ F, 20%, 100 V | 13 | 8131M100651104M | 72982 | |
| C6 | Same as C5 | | | | |
| C7 | Capacitor, Electrolytic, Tantalum: 100 μ F, 20%, 20 V | 2 | 196D107X0020TE4 | 56289 | |
| C8 | Same as C7 | | | | |
| C9 | Capacitor, Electrolytic, Tantalum: 22 μ F, 20%, 10 V | 7 | 196D226X0010JE3 | 56289 | |
| C10 | Capacitor, Ceramic, Disc: 0.01 μ F, 20%, 200 V | 1 | 8131A200Z5U103M | 72982 | |
| C11 | Capacitor, Electrolytic, Tantalum: 220 μ F, 20%, 10 V | 3 | CS138C227K | 56289 | |
| C12 | Same as C11 | | | | |
| C13 | Same as C11 | | | | |
| C14 | Same as C9 | | | | |
| C15 | Same as C5 | | | | |
| C16 Thru C20 | Same as C9 | | | | |
| C21 Thru C30 | Same as C5 | | | | |
| C31 | Capacitor, Ceramic, Disc: 1000 pF, GMV, 500 V | 1 | SM(1000 pF, P) | 91418 | |
| CR1 | Diode | 4 | 1N4446 | 80131 | 93332 |
| CR2 | Same as CR1 | | | | |
| CR3 | Same as CR1 | | | | |
| CR4 | Same as CR1 | | | | |
| Q1 | Transistor | 1 | 2N929 | 80131 | 04713 |
| Q2 | Transistor | 3 | 2N3251 | 80131 | 04713 |
| Q3 | Transistor | 2 | 2N6034 | 80131 | 04713 |
| Q4 | Same as Q3 | | | | |
| Q5 | Same as Q2 | | | | |
| Q6 | Same as Q2 | | | | |
| Q7 | Transistor | 1 | 2N2857 | 80131 | 02735 |
| Q8 | Transistor | 1 | 2N2369 | 80131 | 01295 |
| R1 | Resistor, Fixed, Film: 100 k Ω , 1%, 1/10 W | 1 | RN55C1003F | 81349 | 01121 |
| R2 | Resistor, Fixed, Film: 150 k Ω , 1%, 1/4 W | 1 | MF4C150KF | 80031 | |
| R3 | Resistor, Fixed, Film: 301 Ω , 1%, 1/10 W | 1 | RN55C3010F | 81349 | 75042 |

REF DESIG PREFIX A3A1

| REF DESIG | DESCRIPTION | QTY. PER ASSY. | MANUFACTURER'S PART NO. | MFR. CODE | RECM. VENDOR |
|--------------------|--|----------------------|----------------------------|--------------|-----------------|
| R4 | Resistor, Fixed, Film: 3.01 k Ω , 1%, 1/10 W | 1 | RN55C3011F | 81349 | 75042 |
| R5 | Resistor, Fixed, Film: 3.92 k Ω , 1%, 1/10 W | 4 | RN55C3921F | 81349 | 75047 |
| R6 | Resistor, Fixed, Film: 33.2 k Ω , 1%, 1/10 W | 4 | RN55C3322F | 81349 | 75042 |
| R7 | Resistor, Fixed, Film: 2.21 k Ω , 1%, 1/10 W | 2 | RN55C2211F | 81349 | 75042 |
| R8 | Same as R7 | | | | |
| R9 | Resistor, Fixed, Film: 10 k Ω , 1%, 1/10 W | 16 | RN55C1002F | 81349 | 75042 |
| R10 | Same as R9 | | | | |
| R11 | Same as R9 | | | | |
| R12 | Same as R9 | | | | |
| R13 | Same as R6 | | | | |
| R14 | Same as R5 | | | | |
| R15 | Same as R5 | | | | |
| R16 | Resistor, Fixed, Film: 130 Ω , 1%, 1/10 W | 1 | RN55C1300F | 81349 | 75042 |
| R17 Thru R22 | Same as R9 | | | | |
| R23 | Resistor, Fixed, Film: 1.82 k Ω , 1%, 1/10 W | 1 | RN55C1821F | 81349 | 75042 |
| R24 | Resistor, Fixed, Film: 3.83 k Ω , 1%, 1/10 W | 1 | RN55C3831F | 81349 | 75042 |
| R25 Thru R28 | Same as R9 | | | | |
| R29 | Resistor, Fixed, Film: 46.4 Ω , 1%, 1/4 W | 1 | MF4C46.4F | 80031 | |
| R30 | Resistor, Fixed, Film: 100 Ω , 1%, 1.10 W | 1 | RN55C1000F | 81349 | 75042 |
| R31 | Same as R5 | | | | |
| R32 | Resistor, Fixed, Film: 392 Ω , 1%, 1/10 W | 1 | RN55C3920F | 81349 | 75042 |
| R33 | Resistor, Fixed, Film: 2.0 k Ω , 1%, 1/10 W | 9 | RN55C2001F | 81349 | 75042 |
| R34 Thru R40 | Same as R33 | | | | |
| R41 | Same as R6 | | | | |
| R42 | Same as R6 | | | | |
| R43 | Resistor, Fixed, Composition: 470 k Ω , 5%, 1/4 W | 1 | RCR07G474JS | 81349 | 01121 |
| R44 | Resistor, Fixed, Composition: 750 k Ω , 5%, 1/4 W | 2 | RCR07G754JS | 81349 | 01121 |
| R45 | Resistor, Fixed, Composition: 1.0 M Ω , 5%, 1/4 W | 1 | RCR07G105JS | 81349 | 01121 |
| R46 | Same as R44 | | | | |
| R47 | Resistor, Fixed, Film: 4.22 k Ω , 1%, 1/10 W | 1 | RN55C4221F | 81349 | 75042 |
| R48 | Resistor, Trimmer, Film: 10 k Ω , 10%, 1/2 W | 1 | 62PR10K | 73138 | |
| R49 | Same as R9 | | | | |

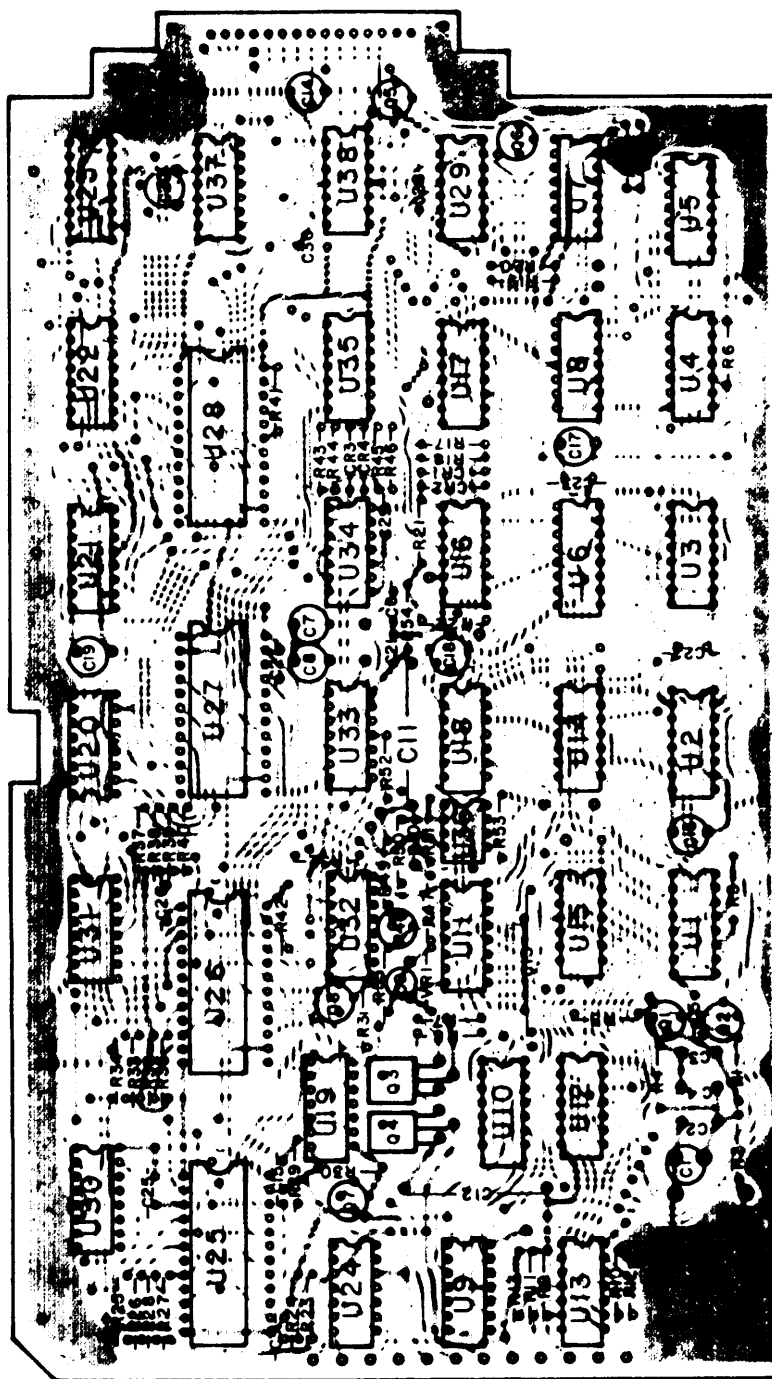


Figure 5-7. Type 791808 Counter Board (A3A1),
Location of Components

REF DESIG PREFIX A3A1

| REF DESIG | DESCRIPTION | QTY PER ASSY | MANUFACTURER'S PART NO. | MFR. CODE | RECM VENDOR |
|--------------|---|--------------------|----------------------------|--------------|----------------|
| R50 | Resistor, Fixed, Film: 100 k Ω , 1%, 1/4 W | 1 | RN55C1003F | 81349 | 75042 |
| R51 | Resistor, Fixed, Film: 221 k Ω , 1%, 1/4 W | 1 | MF4C221K/F | | |
| R52 | Resistor, Fixed, Film: 110 k Ω , 1%, 1/4 W | 1 | MF4C110KF | 80031 | |
| R53 | Same as R9 | | | | |
| R54 | Resistor, Fixed, Film: 221 Ω , 1%, 1/10 W | 1 | RN55C2210F | 81349 | 75042 |
| R55 | Resistor, Fixed, Film: 3.32 k Ω , 1%, 1/10 W | | RN55C3321F | 81349 | 75042 |
| R56 | Same as R33 | | | | |
| U1 | Integrated Circuit | 4 | CD4049AE | 02735 | |
| U2 | Integrated Circuit | 1 | MC14518P | 04713 | |
| U3 | Integrated Circuit | 1 | CD4018AE | 02735 | |
| U4 | Integrated Circuit | 3 | CD4016AE | 02735 | |
| U5 | Integrated Circuit | 3 | CD4001AE | 02735 | |
| U6 | Integrated Circuit | 2 | MC14022P | 04713 | |
| U7 | Same as U6 | | | | |
| U8 | Integrated Circuit | 4 | CD4013AE | 02735 | |
| U9 | Same as U5 | | | | |
| U10 | Integrated Circuit | 3 | CD4011AE | 02735 | |
| U11 | Same as U1 | | | | |
| U12 | Same as U10 | | | | |
| U13 | Same as U4 | | | | |
| U14 | Same as U8 | | | | |
| U15 | Integrated Circuit | 1 | SN54LS74J | 01295 | |
| U16 | Same as U10 | | | | |
| U17 | Same as U1 | | | | |
| U18 | Same as U5 | | | | |
| U19 | Integrated Circuit | 1 | SN541S196J | 18324 | |
| U20 | Integrated Circuit | 1 | SN54LS190J | 01295 | |
| U21 | Integrated Circuit | 3 | MC14510P | 04713 | |
| U22 | Same as U21 | | | | |
| U23 | Same as U21 | | | | |
| U24 | Integrated Circuit | 1 | MC3302P | 04713 | |
| U25 | Integrated Circuit | 4 | MC14508L | 04713 | |
| U26 | Same as U25 | | | | |
| U27 | Same as U25 | | | | |
| U28 | Same as U25 | | | | |
| U29 | Same as U1 | | | | |
| U30 | Integrated Circuit | 2 | MC14585P | 04713 | |

REPLACEMENT PARTS LIST

TM 11-5895-1227-14-1

REF DESIG PREFIX A3A1

| REF DESIG | DESCRIPTION | QTY. PER ASSY. | MANUFACTURER'S PART NO. | MFR. CODE | RECM. VENDOR |
|--------------|---------------------------|----------------------|----------------------------|--------------|-----------------|
| U31 | Same as U30 | | | | |
| U32 | Same as U8 | | | | |
| U33 | Integrated Circuit | 1 | CD4030AE | 02735 | |
| U34 | Same as U8 | | | | |
| U35 | Same as U4 | | | | |
| U36 | Integrated Circuit | 1 | MC1458V | 18324 | |
| U37 | Integrated Circuit | 1 | MC14511P | 04713 | |
| U38 | Integrated Circuit | 1 | SN75492N | 01295 | |
| VR1 | Diode Zener 6.8 V Silicon | 1 | 1N754A | 80131 | 04713 |
| Y1 | Crystal, Quartz: 1 MHz | 1 | NE33A | 00815 | |

5.5.2.1.1 Part 24947 Display Board

REF DESIG PREFIX A3A1A1

| REF DESIG | DESCRIPTION | QTY. PER ASSY. | MANUFACTURER'S PART NO. | MFR. CODE | RECM. VENDOR |
|------------------|--|----------------|-------------------------|-----------|--------------|
| R1 | Resistor, Fixed, Film: 121 Ω , 1%, 1/10 W | 7 | RN55C1210F | 81349 | 75042 |
| R2 Thru R7 | Same as R1 | | | | |
| U1 | Numeric Indicator | 2 | 5082-7404 | 28480 | |
| U2 | Same as U1 | | | | |

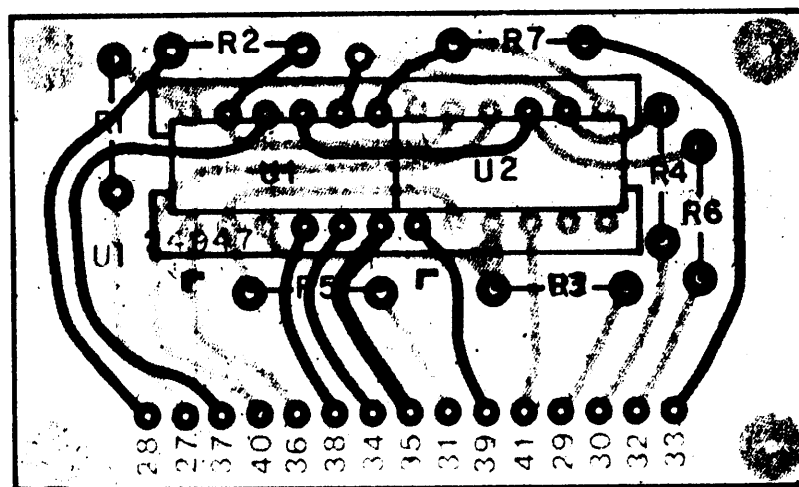


Figure 5-8. Part 24947 Display Board (A3A1A1),
Location of Components

5. 5.2.2 Part 34912 Wideband Amplifier and First Counter

REF DESIG PREFIX A3A2

| REF DESIG | DESCRIPTION | QTY. PER ASSY. | MANUFACTURER'S PART NO. | MFR. CODE | RECM. VENDOR |
|---------------------|---|----------------------|----------------------------|--------------|-----------------|
| C1 | Capacitor, Ceramic, Disc: 4700 pF, 10%, 200 V | 7 | CK06BX472K | 81349 | 56289 |
| C2 | Capacitor, Variable, Ceramic: 5-25 pF, 100 V N750 | 1 | 518-000A5-25 | 72982 | |
| C3 Thru C6 | Same as C1 | | | | |
| C7 | Capacitor, Ceramic, Disc: 0.01 μ F, 10%, 200 V | 1 | CK06BX103K | 81349 | 56289 |
| C8 | Capacitor, Electrolytic, Tantalum: 100 μ F, 10%, 20 V | 5 | CS13BE107K | 81349 | 56289 |
| C9 | Same as C8 | | | | |
| C10 | Same as C1 | | | | |
| C11 | Capacitor, Ceramic, Disc: 1000 pF, 10%, 200 V | 6 | CK05BX102K | 81349 | 56289 |
| C12 | Capacitor, Ceramic, Disc: 0.1 μ F, 10%, 100 V | 5 | CK06BX104K | 81349 | 56289 |
| C13 | Same as C12 | | | | |
| C14 | Same as C11 | | | | |
| C15 | Same as C12 | | | | |
| C16 | Same as C11 | | | | |
| C17 | Same as C12 | | | | |
| C18 | Same as C11 | | | | |
| C19 | Same as C12 | | | | |
| C20 | Same as C11 | | | | |
| C21 | Same as C8 | | | | |
| C22 | Same as C8 | | | | |
| C23 | Same as C8 | | | | |
| C24 | Same as C11 | | | | |
| C25 | Same as C1 | | | | |
| CR1 | Diode | 2 | 5082-2900 | 28480 | |
| CR2 | Same as CR1 | | | | |
| CR3 | Diode | 1 | 1N198A | 80131 | |
| CR4 | Not Used | | | | |
| CR5 | Diode | 2 | 1N4446 | 80131 | |
| CR6 | Same as CR5 | | | | |
| E1 | Terminal, Forked | 15 | 140-1941-02-01 | 71279 | |
| E2 Thru E15 | Same as E1 | | | | |
| FB1 | Ferrite Bead | 14 | 56-590-65-4A | 02114 | |
| FB2 Thru FB14 | Same as FB1 | | | | |
| L1 | Coil, Fixed | 1 | 21210-146 | 14632 | |
| L2 | Coil, Fixed | 1 | 21210-145 | 14632 | |

REF DESIG PREFIX A3A2

| REF DESIG | DESCRIPTION | QTY. PER ASSY. | MANUFACTURER'S PART NO. | MFR. CODE | RECM. VENDOR |
|--------------|---|----------------------|----------------------------|--------------|-----------------|
| L3 | Coil, Fixed, Mold: .22 μ H, 10% | 4 | 1025-04 | 99800 | |
| L4 | Same as L3 | | | | |
| L5 | Same as L3 | | | | |
| L6 | Same as L3 | | | | |
| L7 | Coil, Fixed | 4 | 16209-6 | 14632 | |
| L8 | Same as L7 | | | | |
| L9 | Same as L7 | | | | |
| L10 | Same as L7 | | | | |
| Q1 | Transistor | 2 | 2N2857 | 80131 | 02735 |
| Q2 | Transistor | 1 | U310 | 17856 | |
| Q3 | Transistor | 2 | 2N930 | 80131 | 04713 |
| Q4 | Not Used | | | | |
| Q5 | Not Used | | | | |
| Q6 | Same as Q3 | | | | |
| Q7 | Transistor | 2 | 2N3251 | 80131 | 04713 |
| Q8 | Same as Q7 | | | | |
| Q9 | Same as Q1 | | | | |
| R1 | Resistor, Fixed, Film: 18.2 Ω , 1%, 1/4 W | 2 | CC18R2F | 01121 | |
| R2 | Same as R1 | | | | |
| R3 | Resistor, Fixed, Film: 6.81 k Ω , 1%, 1/10 W | 1 | RN55C6811F | 81349 | 75042 |
| R4 | Resistor, Fixed, Film: 4.64 k Ω , 1%, 1/10 W | 1 | RN55C4641F | 81349 | 75042 |
| R5 | Resistor, Fixed, Film: 825 Ω , 1%, 1/10 W | 1 | RN55C8250F | 81349 | 75042 |
| R6 | Resistor, Fixed, Composition: 22 Ω , 5%, 1/4 W | 2 | RCR07G220JS | 81349 | 01121 |
| R7 | Resistor, Trimmer, Film: 100 Ω , 10%, 1/2 W | 1 | 62PR100 | 73138 | |
| R8 | Resistor, Fixed, Film: 475 Ω , 1%, 1/10 W | 5 | RN55C4750F | 81349 | 75042 |
| R9 | Resistor, Fixed, Film: 49.9 Ω , 1%, 1/10 W | 3 | RN55C49R9F | 81349 | 75042 |
| R10 | Resistor, Trimmer, Film: 2 k Ω , 10%, 1/2 W | 1 | 62PR2K | 73138 | |
| R11 | Resistor, Fixed, Film: 100 k Ω , 1%, 1/10 W | 1 | RN55C1003F | 81349 | 75042 |
| R12 | Same as R6 | | | | |
| R13 | Resistor, Fixed, Film: 10 Ω , 1%, 1/4 W | 9 | CC10R0F | 01121 | |
| R14 | Same as R13 | | | | |
| R15 | Same as R13 | | | | |
| R16 | Not Used | | | | |
| R17 | Not Used | | | | |
| R18 | Not Used | | | | |
| R19 | Same as R13 | | | | |

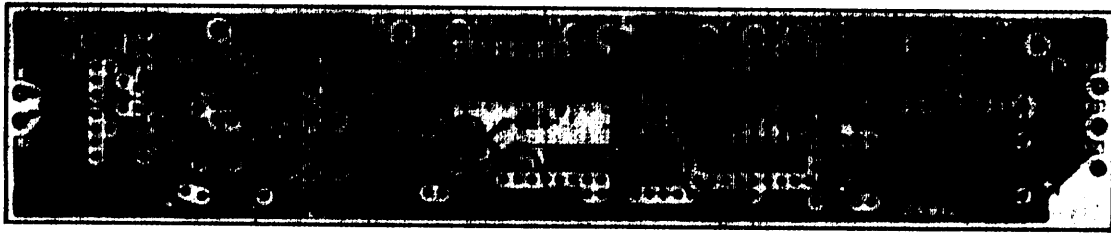


Figure 5-9. Part 34912 Wideband Amplifier and First Counter (A3A2),
Location of Components

REF DESIG PREFIX A3A2

| REF DESIG | DESCRIPTION | QTY PER ASSY | MANUFACTURER'S PART NO. | MFR. CODE | RECM VENDOR |
|--------------|--|--------------------|----------------------------|--------------|----------------|
| R20 | Resistor, Fixed, Film: 332 Ω , 1%, 1/10 W | 3 | RN55C3320F | 81349 | 75042 |
| R21 | Resistor, Fixed, Film: 1.21 k Ω , 1%, 1/10 W | 1 | RN55C1211F | 81349 | 75042 |
| R22 | Resistor, Trimmer, Film: 1 k Ω , 10%, 1/2 W | 1 | 62PR1K | 73138 | |
| R23 | Resistor, Fixed, Film: 2.0 k Ω , 1%, 1/10 W | 1 | RN55C2001F | 81349 | 75042 |
| R24 | Resistor, Fixed, Film: 274 Ω , 1%, 1/10 W | 3 | RN55C2740F | 81349 | 75042 |
| R25 | Same as R20 | | | | |
| R26 | Same as R24 | | | | |
| R27 | Same as R20 | | | | |
| R28 | Same as R9 | | | | |
| R29 | Resistor, Fixed, Film: 39.2 Ω , 1%, 1/4 W | 4 | MF4C39.2F | 81349 | 75042 |
| R30 | Same as R8 | | | | |
| R31 | Same as R9 | | | | |
| R32 | Resistor, Fixed, Film: 511 Ω , 1%, 1/10 W | 1 | RN55C5110F | 81349 | 75042 |
| R33 | Same as R29 | | | | |
| R34 | Same as R8 | | | | |
| R35 | Same as R29 | | | | |
| R36 | Same as R8 | | | | |
| R37 | Same as R29 | | | | |
| R38 | Same as R8 | | | | |
| R39 | Same as R13 | | | | |
| R40 | Resistor, Fixed, Film: 324 Ω , 1%, 1/10 W | 1 | RN55C3240F | | |
| R41 | Same as R13 | | | | |
| R42 | Resistor, Fixed, Composition: 39 Ω , 5%, 1/4 W | 1 | RCR07G390JS | 81349 | 01121 |
| R43 | Resistor, Fixed, Composition: 2.7 Ω , 5%, 1/4 W | 2 | RCR07G2R7JS | 81349 | 01121 |
| R44 | Same as R43 | | | | |
| R45 | Resistor, Fixed, Film: 365 Ω , 1%, 1/10 W | 2 | RN55C3650F | 81349 | 75042 |
| R46 | Same as R45 | | | | |
| R47 | Same as R13 | | | | |
| R48 | Same as R24 | | | | |
| R49 | Same as R13 | | | | |
| R50 | Same as R13 | | | | |
| T1 | Transformer | 1 | 21278-19 | 14632 | |
| U1 | Integrated Circuit | 2 | GPD462 | 24539 | |
| U2 | Same as U1 | | | | |
| U3 | Integrated Circuit | 1 | MC1690L | 04713 | |
| U4 | Integrated Circuit | 1 | MC10138L | 04713 | |

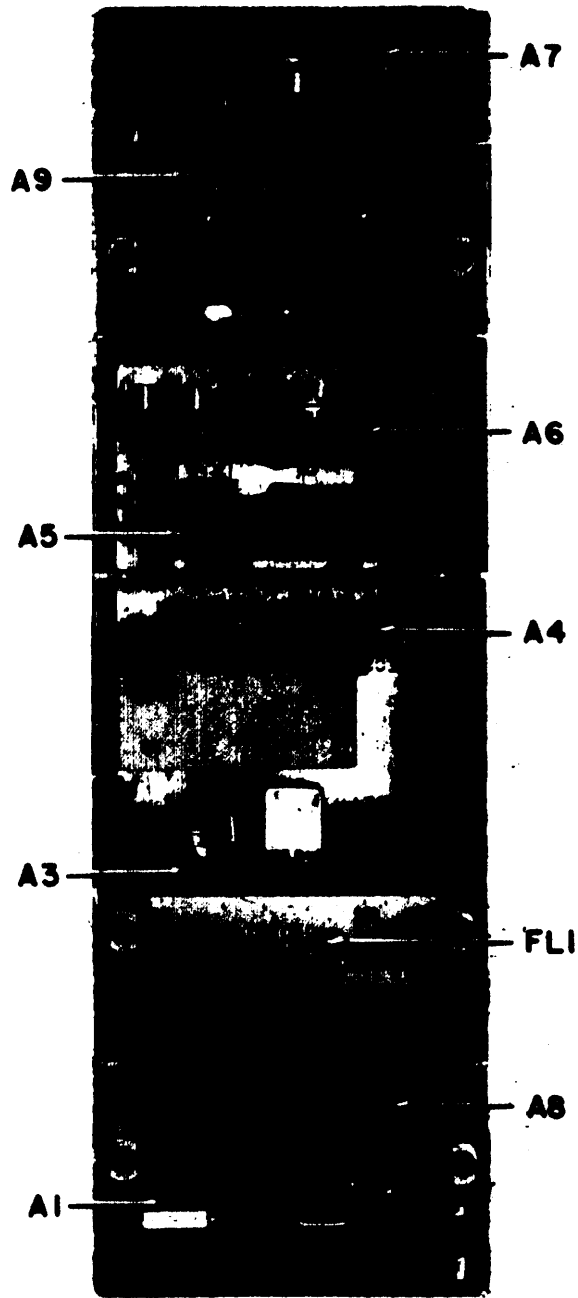


Figure 5-10. Type 791800-1 IF Demodulator Assembly (A4),
Top View, Location of Components

TM 11-5895-1227-14-1

REPLACEMENT PARTS LIST

.53 TYPE 791800-1 IF DEMODULATOR ASSEMBLY REF DESIG PREFIX A4

| REF DESIG | DESCRIPTION | QTY PER ASSY | MANUFACTURER'S PART NO. | MFR. CODE | RECM VENDOR |
|--------------------|---|--------------|-------------------------|-----------|-------------|
| A1 | 21.4/10 MHz Converter | 1 | 794021 | 14632 | |
| A2 | Bandwidth Control Board | 1 | 24996 | 14632 | |
| A3 | Gain BW Component Amplifier | 1 | 791802 | 14632 | |
| A4 | IF Filter and Diode Switches | 1 | 791803-1 | 14632 | |
| A5 | 10 MHz Amplifier | 2 | 791804 | 14632 | |
| A6 | AM Detector/Buffer | 1 | 791790 | 14632 | |
| A7 | Product Detector | 1 | 791785 | 14632 | |
| A8 | Same as A5 | | | | |
| A9 | LSB/USB Filters | 1 | 791805 | 14632 | |
| C1 | Capacitor, Ceramic, Feedthru: .05 μ F, GMV 300 V | 13 | 54-785-002-503P | 33095 | |
| C2 Thru C7 | Same as C1 | | | | |
| C8 | Capacitor, Ceramic, Feedthru: 33 pF, 10%, 500 V | 1 | 54-794-001-3301 | 33095 | |
| C9 | Capacitor, Ceramic, Feedthru: 330 pF, 10%, 500 V | 1 | 54-794-001-3311 | 33095 | |
| C10 Thru C13 | Same as C1 | | | | |
| C14 | Capacitor, Electrolytic, Tantalum: 100 μ F, 20%, 20 V | 1 | 196D107X0020TE4 | 56289 | |
| C15 | Capacitor, Ceramic, Disc: 0.01 μ F, 20%, 200 V | 3 | 8131A200Z5U103M | 72982 | |
| C16 | Same as C15 | | | | |
| C17 | Capacitor, Ceramic, Feedthru: 470 pF, 20%, 500 V | 1 | 54-794-009-471M | 33095 | |
| C18 | Same as C15 | | | | |
| C19 | Same as C1 | | | | |
| C20 | Same as C1 | | | | |
| CR1 | Diode | 2 | 1N4449 | 80131 | 93332 |
| CR2 | Same as CR1 | | | | |
| E1 | Terminal, Feedthru, Insulated | 7 | SFU16Y | 04013 | |
| E2 Thru E7 | Same as E1 | | | | |
| FB1 | Ferrite Bead | 1 | 56-590-65-4A | 02114 | |
| FL1 | Filter | 1 | 92163 | 14632 | |
| J1 | Connector, Receptacle: SMB Series | 5 | 212 | 19505 | |
| J2 Thru J5 | Same as J1 | | | | |
| L1 | Coil, Fixed: 10 μ H, 10% | 1 | 1537-36 | 99800 | |
| P1 | Connector, Plug: SRE Series | 1 | SRE20PNSSH13 | 81312 | |
| R1 | Resistor, Fixed, Composition: 1.0 k Ω , 5%, 1/4 W | 1 | RCR07G102JS | 81349 | 01121 |

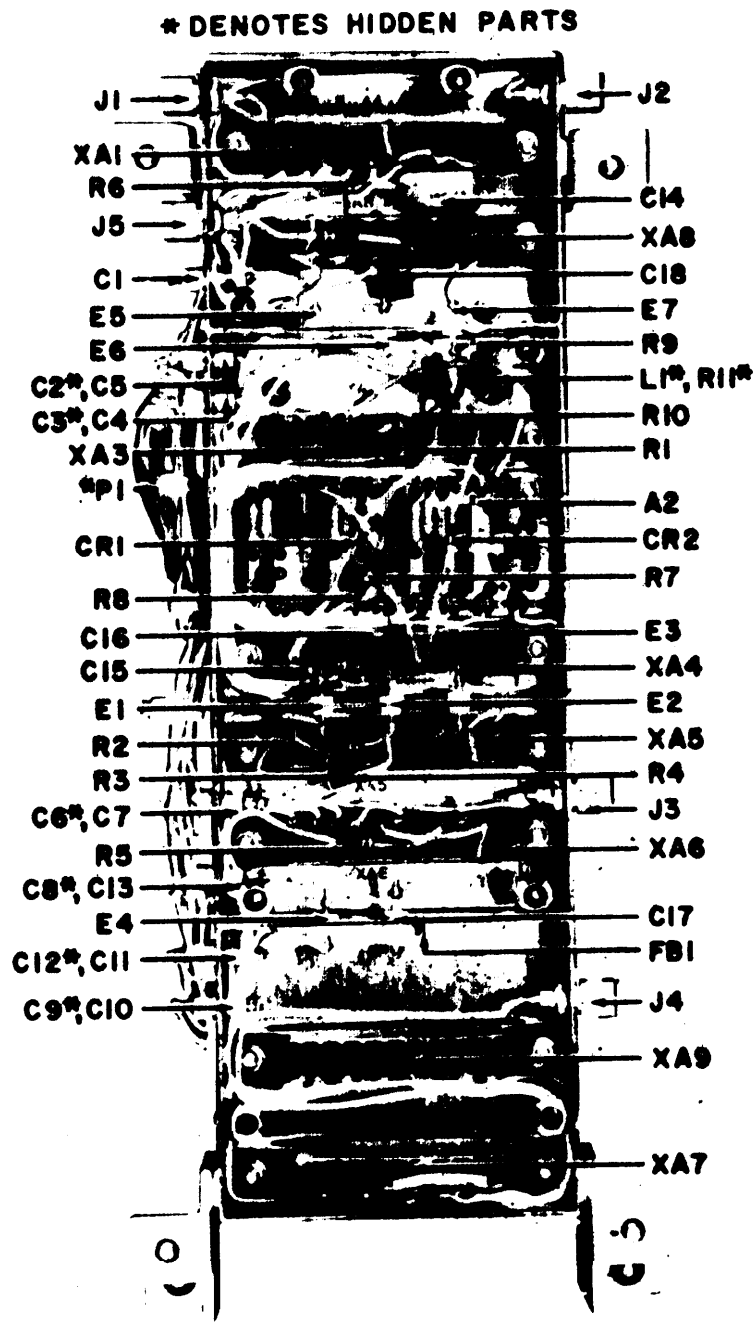


Figure 5-11. Type 791800-1 IF Demodulator Assembly (A4), Bottom View, Location of Components

REF DESIG PREFIX A4

| REF DESIG | DESCRIPTION | QTY. PER ASSY. | MANUFACTURER'S PART NO. | MFR. CODE | RECM. VENDOR |
|--------------------|--|----------------------|----------------------------|--------------|-----------------|
| R2 | Resistor, Fixed, Composition: 100 Ω , 5%, 1/4 W | 4 | RCR07G101JS | 81349 | 01121 |
| R3 | Same as R2 | | | | |
| R4 | Resistor, Fixed, Composition: 10 Ω , 5%, 1/4 W | 1 | RCR07G100JS | 81349 | 01121 |
| R5 | Same as R2 | | | | |
| R6 | Same as R2 | | | | |
| R7 | Resistor, Fixed, Composition: 5.1 k Ω , 5%, 1/4 W | 4 | RCR07G512JS | 81349 | 01121 |
| R8 | Same as R7 | | | | |
| R9 | Same as R7 | | | | |
| R10 | Same as R7 | | | | |
| R11 | Resistor, Fixed, Composition: 330 Ω , 5%, 1/4 W | 1 | RCR07G331JS | 81349 | 01121 |
| XA1 | Connector, PC Board | 8 | 251-10-30-160 | 71785 | |
| XA3 Thru XA9 | Same as XA1 | | | | |

5. 5.3.1 Type 794021 21.4 to 10 MHz Converter

REF DESIG PREFIX A4A1

| REF DESIG | DESCRIPTION | QTY. PER ASSY. | MANUFACTURER'S PART NO. | MFR. CODE | RECM. VENDOR |
|--------------|--|----------------------|----------------------------|--------------|-----------------|
| C1 | Capacitor, Ceramic, Disc: .01 μ F, 10%, 200 V | 7 | CK06BX103K | 81349 | 56289 |
| C2 | Capacitor, Mica, Dipped: 360 pF, 2%, 500 V | 1 | CM05FD361G03 | 81349 | 72136 |
| C3 | Capacitor, Mica, Dipped: 820 pF, 5%, 300 V | 1 | DM15-821J | 72136 | |
| C4 | Same as C1 | | | | |
| C5 | Same as C1 | | | | |
| C6 | Capacitor, Electrolytic, Tantalum: 15 μ F, 10%, 20 V | 1 | CS13BE156K | 81349 | 56289 |
| C7 | Same as C1 | | | | |
| C8 | Same as C1 | | | | |
| C9 | Same as C1 | | | | |
| C10 | Capacitor, Mica, Dipped: 120 pF, 2%, 500 V | 2 | CM04FD121G03 | 81349 | 72136 |
| C11 | Same as C10 | | | | |
| C12* | Capacitor, Mica, Dipped: 22 pF, 5%, 500 V | 1 | CM05ED220J03 | 81349 | 72136 |
| C13 | Capacitor, Variable, Ceramic: 5-25 pF, 100 V | 1 | 518-000A5-25 | 72982 | |
| C14 | Capacitor, Mica, Dipped: 75 pF, 2%, 500 V | 1 | CM05ED750G03 | 81349 | 72136 |
| C15 | Same as C1 | | | | |
| CR1 | Diode | 1 | 1N4449 | 80131 | 93332 |
| L1 | Coil, Variable: .22 μ H | 1 | 558-7107-05 | 71279 | |
| L2 | Coil, Fixed, Molded: 39 μ H | 2 | 1025-58 | 99800 | |
| L3 | Same as L2 | | | | |
| L4 | Coil, Variable | 1 | 558-7107-10 | 71279 | |
| Q1 | Transistor | 1 | 2N2857/JAN | 80131 | 02735 |
| Q2 | Transistor | 1 | U320 | 17856 | |
| R1 | Resistor, Fixed, Composition: 75 Ω , 5%, 1/4 W | 1 | RCR07G750JS | 81349 | 01121 |
| R2 | Resistor, Fixed, Film: 5.62 k Ω , 1%, 1/10 W | 2 | RN55C5621F | 81349 | 75042 |
| R3 | Resistor, Fixed, Film: 2.21 k Ω , 1%, 1/10 W | 1 | RN55C2211F | 81349 | 75042 |
| R4 | Resistor, Fixed, Film: 1.1 k Ω , 1%, 1/10 W | 1 | RN55C1101F | 81349 | 75042 |
| R5 | Resistor, Fixed, Film: 47.5 Ω , 1%, 1/10 W | 1 | RN55C4750F | 81349 | 75042 |
| R6 | Resistor, Fixed, Composition: 68 Ω , 5%, 1/4 W | 1 | RCR07G680JS | 81349 | 01121 |
| R7 | Resistor, Fixed, Film: 150 Ω , 1%, 1/10 W | 4 | RN55C1500F | 81349 | 75042 |
| R8 | Same as R7 | | | | |
| R9 | Resistor, Fixed, Film: 221 Ω , 1%, 1/10 W | 1 | RN55C2210F | 81349 | 75042 |
| R10 | Resistor, Fixed, Film: 100 Ω , 1%, 1/10 W | 1 | RN55C1000F | 81349 | 75042 |
| R11 | Resistor, Fixed, Film: 2.74 k Ω , 1%, 1/10 W | 1 | RN55C2741F | 81349 | 75042 |
| R12 | Resistor, Fixed, Composition: 36 Ω , 5%, 1/4 W | 1 | RCR07G360JS | 81349 | 01121 |
| R13 | Same as R7 | | | | |
| | *Nominal Value, Final Value Factory Selected. | | | | |

REF DESIG PREFIX A4A1

| REF DESIG | DESCRIPTION | QTY. PER ASSY. | MANUFACTURER'S PART NO. | MFR. CODE | RECM. VENDOR |
|--------------|--|----------------------|----------------------------|--------------|-----------------|
| R14 | Same as R2 | | | | |
| R15 | Same as R7 | | | | |
| R16 | Resistor, Fixed, Composition: 470 Ω , 5%, 1/4 W | | RCR07G471JS | 81349 | 01121 |
| U1 | Mixer | 1 | M6E | 27956 | |
| Y1 | Crystal Quartz: 31.400 MHz | 1 | 91807-7 | 14632 | |

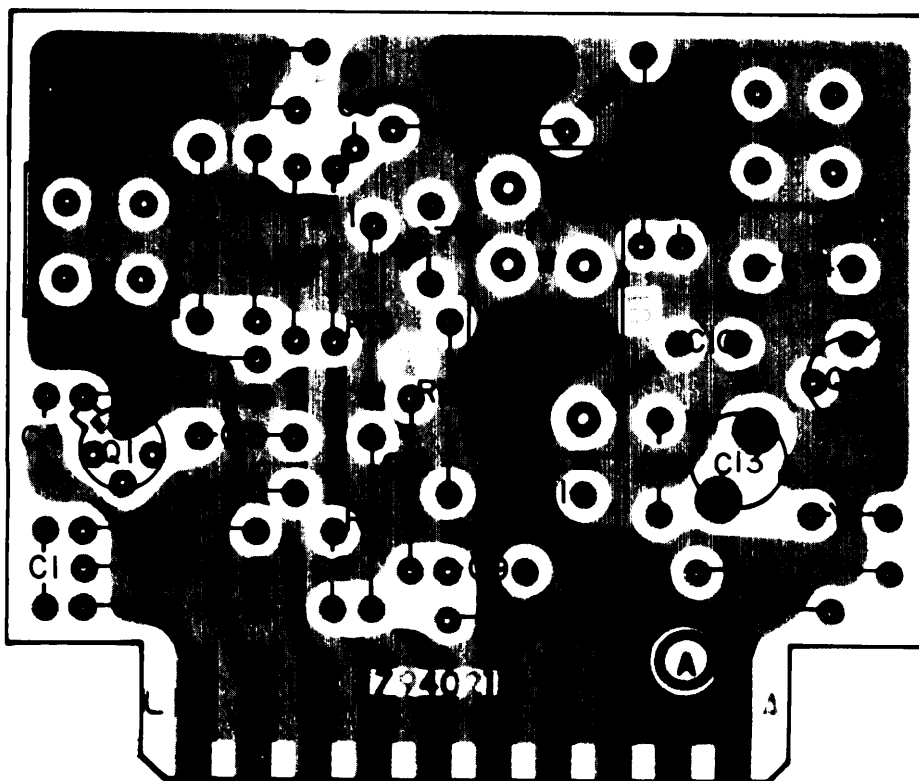


Figure 5-12. Type 79402121.4 to 10 MHz Converter (A4A1),
Location of Components

5.5.3.1 Type 794485-1 21.4 to 10 MHz Converter

REF DESIG PREFIX A4A1

| REF DESIG | DESCRIPTION | QTY PER ASSY | MANUFACTURER'S PART NO. | MFR. CODE | RECM VENDOR |
|------------------|--|--------------------|----------------------------|--------------|----------------|
| C1 | Capacitor, Ceramic, Disc: .01 μ F, 10%, 200 V | 7 | CK06BX103K | 81349 | 56289 |
| C2 | Capacitor, Mica, Dipped: 360 pF, 2%, 500 V | 1 | CM05FD361G03 | 81349 | 72136 |
| C3 | Capacitor, Mica, Dipped: 820 pF | 1 | CK05BX821K | 81349 | |
| C4 | Same as C1 | | | | |
| C5 | Same as C1 | | | | |
| C6 | Capacitor, Electrolytic, Tantalum: 15 μ F, 10%, 20 V | 1 | CS13BE156K | 81349 | 56289 |
| C7 Thru C9 | Same as C1 | | | | |
| C10 | Capacitor, Mica, Dipped: 120 pF, 2%, 500 V | 2 | CM04FD121G03 | 81349 | 72136 |
| C11 | Same as C10 | | | | |
| C12 | Capacitor, Mica, Dipped: 75 pF, 2%, 500 V | 1 | CM05ED750G03 | 81349 | 72136 |
| C13 | Same as C1 | | | | |
| CR1 | Diode | 1 | 1N4449 | 80131 | 93332 |
| CR2 | Diode | 1 | 5082-3080 | 28480 | |
| L1 | Coil, Variable: 0.198-0.24 μ H | 1 | 558-7107-05 | 71279 | |
| L2 | Coil, Fixed, Molded: 39 μ H | 2 | 1025-58 | 99800 | |
| L3 | Same as L2 | | | | |
| L4 | Coil, Variable: 0.504-0.616 μ H | 1 | 558-7107-10 | 71279 | |
| L5 | Coil, Fixed, Molded: .82 μ H, 10% | 1 | 1025-18 | 99800 | |
| Q1 | Transistor | 1 | 2N2857/JAN | 80131 | 02735 |
| Q2 | Transistor | 1 | U320 | 17856 | |
| R1 | Resistor, Fixed, Composition: 75 Ω , 5%, 1/4 W | 1 | RCR07G750JS | 81349 | 01121 |
| R2 | Resistor, Fixed, Film: 4.75 k Ω , 1%, 1/10 W | 1 | RN55C475 | 81349 | 75042 |
| R3 | Resistor, Fixed, Film: 2.21 k Ω , 1%, 1/10 W | 1 | RN55C2211F | 81349 | 75042 |
| R4 | Resistor, Fixed, Film: 1.1 k Ω , 1%, 1/10 W | 1 | RN55C1101F | 81349 | 75042 |
| R5 | Resistor, Fixed, Film: 392 Ω , 1%, 1/10 W | 1 | RN55C3920F | 81349 | 75042 |
| R6 | Resistor, Fixed, Composition: 36 Ω , 5%, 1/4 W | 2 | RCR07360JS | 81349 | 01121 |
| R7 | Resistor, Fixed, Film: 150 Ω , 1%, 1/10 W | 4 | RN55C1500F | 81349 | 75042 |
| R8 | Same as R7 | | | | |
| R9 | Resistor, Fixed, Film: 221 Ω , 1%, 1/10 W | 1 | RN55C2210F | 81349 | 75042 |
| R10 | Resistor, Fixed, Film: 100 Ω , 1%, 1/10 W | 1 | RN55C1000F | 81349 | 75042 |
| R11 | Resistor, Fixed, Film: 2.74 k Ω , 1%, 1/10 W | 1 | RN55C2741F | 81349 | 75042 |
| R12 | Same as R6 | | | | |
| R13 | Same as R7 | | | | |
| R14 | Resistor, Fixed, Film: 5.62 k Ω , 1%, 1/10 W | 1 | RN55C5621F | 81349 | |
| R15 | Same as R7 | | | | |
| R16 | Resistor, Fixed, Composition: 470 Ω , 5%, 1/4 W | 1 | RCR07G471JS | 81349 | 01121 |
| U1 | Mixer | 1 | M6E | 27956 | |
| Y1 | Crystal Quartz: 31.400 MHz | 1 | 91807-7 | 14632 | |

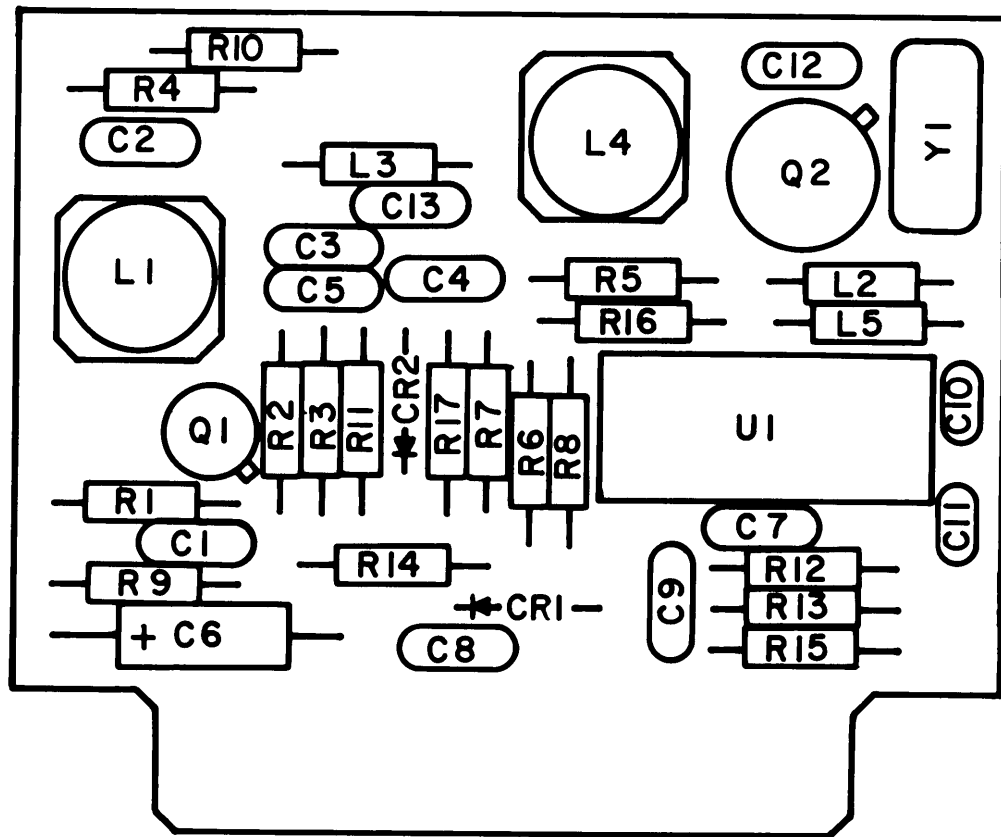


Figure 5-12.1. Type 794485-1 21.4 to 10 MHz Converter (A4A1),
Location of Components

FIGURE 5-13

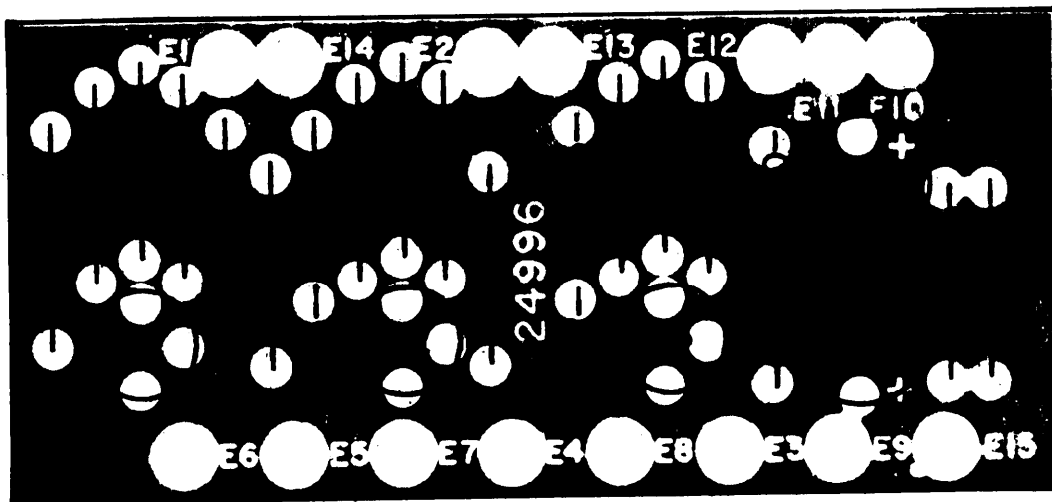


Figure 5-13. Part 24996 BW Control (A4A2),
Location of Components

TM 11-5895-1227-14-1

REPLACEMENT PARTS LIST

5. 5.3.2 Part 24996 BW Control

REF DESIG PREFIX A4A2

| REF DESIG | DESCRIPTION | QTY. PER ASSY. | MANUFACTURER'S PART NO. | MFR. CODE | RECM. VENDOR |
|-------------------|--|----------------------|----------------------------|--------------|-----------------|
| C1 | Capacitor, Ceramic, Disc: 0.01 μ F, 10%, 200 V | 9 | CK06BX103K | 81349 | 56289 |
| C2 Thru C8 | Same as C1 | | | | |
| C9 | Capacitor, Electrolytic, Tantalum: 15 μ F, 20%, 15 V | 2 | 196D156X0015JE3 | 56289 | |
| C10 | Same as C1 | | | | |
| C11 | Same as C9 | | | | |
| E1 | Terminal | 15 | 140-1941-02-01 | 71279 | |
| E2 Thru E15 | Same as E1 | | | | |
| Q1 | Transistor | 3 | U1899E | 15818 | |
| Q2 | Same as Q1 | | | | |
| Q3 | Same as Q1 | | | | |
| R1 | Resistor, Fixed, Film: 100 Ω , 1%, 1/10 W | 3 | RN55C1000F | 81349 | 75042 |
| R2 | Same as R1 | | | | |
| R3 | Resistor, Fixed, Film: 100 k Ω , 1%, 1/10 W | 3 | RN55C1003F | 81349 | 75042 |
| R4 | Same as R3 | | | | |
| R5 | Same as R3 | | | | |
| R6 | Resistor, Fixed, Film: 1.1 k Ω , 1%, 1/10 W | 3 | RN55C1101F | 81349 | 75042 |
| R7 | Same as R6 | | | | |
| R8 | Same as R1 | | | | |
| R9 | Same as R6 | | | | |
| R10 | Resistor, Fixed, Film: 33.2 k Ω , 1%, 1/10 W | 3 | RN55C3322F | 81349 | 75042 |
| R11 | Same as R10 | | | | |
| R12 | Same as R10 | | | | |
| R13 | Resistor, Fixed, Composition: 47 Ω , 5%, 1/4 W | 1 | RCR07G470JS | 81349 | 01121 |

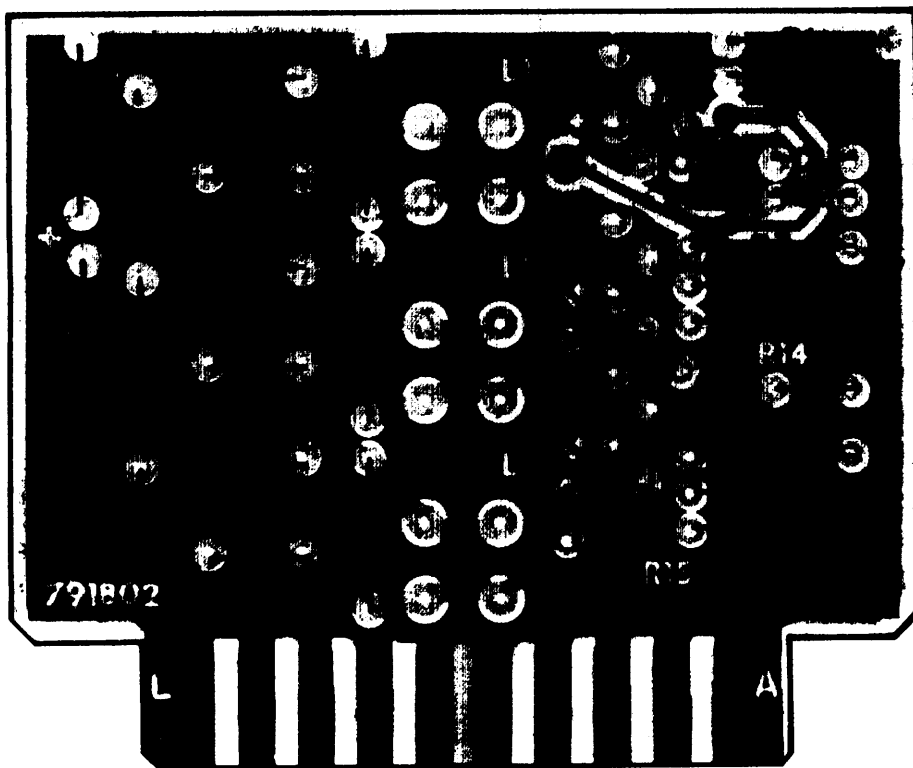


Figure 5-14. Type 791802 Gain Bandwidth Compensation Amplifier (A4A3),
Location of Components

TM 11-5895-1227-14-1

REPLACEMENT PARTS LIST

5. 5.3.3 Type 791802 Gain Bandwidth Compensation Amplifier

REF DESIG PREFIX A4A3

| REF DESIG | DESCRIPTION | QTY. PER ASSY. | MANUFACTURER'S PART NO. | MFR. CODE | RECM. VENDOR |
|------------------|--|----------------------|----------------------------|--------------|-----------------|
| C1 | Capacitor, Ceramic, Disc: 0.01 μ F, 10%, 200 V | 9 | CK06BX103K | 81349 | 56289 |
| C2 Thru C6 | Same as C1 | | | | |
| C7 | Capacitor, Mica, Dipped: 250 pF, 5%, 500 V | 3 | DM15-251J | 72136 | |
| C8 | Capacitor, Mica, Dipped: 560 pF, 5%, 300 V | 2 | DM15-561J | 72136 | |
| C9 | Same as C7 | | | | |
| C10 | Capacitor, Mica, Dipped: 300 pF, 2%, 500 V | 1 | CM05FD301G03 | 81349 | |
| C11 | Same as C7 | | | | |
| C12 | Same as C8 | | | | |
| C13 | Same as C1 | | | | |
| C14 | Same as C1 | | | | |
| C15 | Same as C1 | | | | |
| C16 | Capacitor, Electrolytic, Tantalum: 15 μ F, 10%, 20 V | 1 | CS13BE156K | 81349 | 56289 |
| C17 | Capacitor, Ceramic, Disc: 10 pF, 10%, 50 V | 1 | 1C10RK | 93958 | |
| L1 | Coil, Variable: 1.35-1.65 μ H | 3 | 558-7107-15 | 71279 | |
| L2 | Same as L1 | | | | |
| L3 | Same as L1 | | | | |
| Q1 | Transistor | 3 | 2N2857/JAN | 80131 | 02735 |
| Q2 | Same as Q1 | | | | |
| Q3 | Same as Q1 | | | | |
| R1 | Resistor, Fixed, Film: 5.62 k Ω , 1%, 1/10 W | 3 | RN55C5621F | 81349 | 75042 |
| R2 | Resistor, Fixed, Film: 2.21 k Ω , 1%, 1/10 W | 3 | RN55C2211F | 81349 | 75042 |
| R3 | Same as R1 | | | | |
| R4 | Same as R2 | | | | |
| R5 | Same as R1 | | | | |
| R6 | Same as R2 | | | | |
| R7 | Resistor, Fixed, Film: 3.92 k Ω , 1%, 1/10 W | 3 | RN55C3921F | 81349 | 75042 |
| R8 | Resistor, Fixed, Film: 475 Ω , 1%, 1/10 W | 1 | RN55C4750F | 81349 | 75042 |
| R9 | Same as R7 | | | | |
| R10 | Resistor, Fixed, Film: 274 Ω , 1%, 1/10 W | 1 | RN55C2740F | 81349 | 75042 |
| R11 | Same as R7 | | | | |
| R12 | Resistor, Fixed, Film: 200 Ω , 1%, 1/10 W | 1 | RN55C2000F | 81349 | |
| R13 | Resistor, Trimmer, Film: 500 Ω , 10%, 1/2 W | 3 | 62PR500 | 73138 | |
| R14 | Same as R13 | | | | |
| R15 | Same as R13 | | | | |
| R16 | Resistor, Fixed, Film: 150 Ω , 1%, 1/10 W | 1 | RN55C1500F | 81349 | 75042 |

5.5.3.4 Type 791803-1 IF Filters and Diode Switches

REF DESIG PREFIX A4A4

| REF DESIG | DESCRIPTION | QTY. PER ASSY. | MANUFACTURER'S PART NO. | MFR. CODE | RECM. VENDOR |
|--------------------|---|----------------------|----------------------------|--------------|-----------------|
| C1 | Capacitor, Ceramic, Disc: 0.01 μ F, 10%, 200 V | 6 | CK06BX103K | 81349 | 56289 |
| C2 Thru C6 | Same as C1 | | | | |
| CR1 | Diode | 6 | 1N4449 | 80131 | 93332 |
| CR2 Thru CR6 | Same as CR1 | | | | |
| FL1 | Crystal, Filter | 1 | 15973-1 | 14632 | |
| FL2 | Crystal, Filter | 1 | 15973-3 | 14632 | |
| R1 | Resistor, Fixed, Film: 100 k Ω , 1%, 1/10 W | 3 | RN55C1003F | 81349 | 75042 |
| R2 | Same as R1 | | | | |
| R3 | Same as R1 | | | | |
| R4 | Resistor, Fixed, Film: 221 Ω , 1%, 1/10 W | 1 | RN55C2210F | 81349 | 75042 |
| R5 | Resistor, Fixed, Film: 12.1 k Ω , 1%, 1/10 W | 3 | RN55C1212F | 81349 | 75042 |
| R6 | Same as R5 | | | | |
| R7 | Same as R5 | | | | |

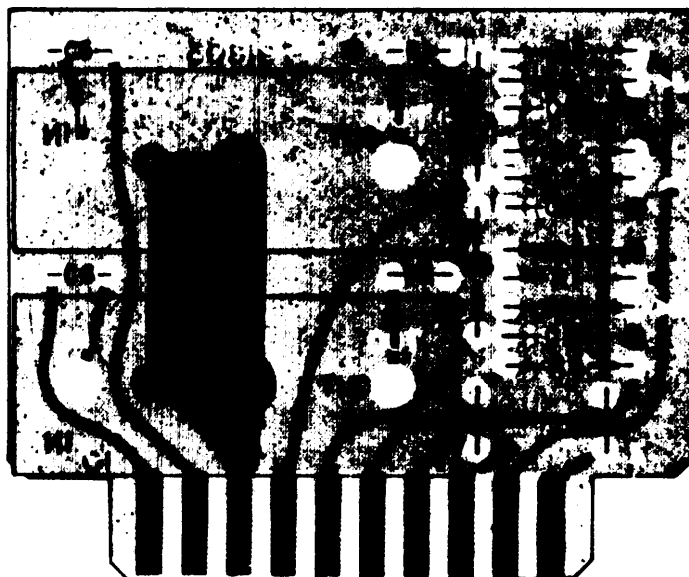


Figure 5-15. Type 791303-1 IF Filters & Diode Switches (A4A4), Location of Components

5.5.3.5 Type 791804-1 10 MHz Amplifier

REF DESIG PREFIX A4A5. A4A8

| REF DESIG | DESCRIPTION | QTY PER ASSY | MANUFACTURER'S PART NO. | MFR. CODE | RECM VENDOR |
|-----------|--|--------------|-------------------------|-----------|-------------|
| C1 | Capacitor, Ceramic, Disc: 0.01 μ F, 10%, 300 V | 2 | CK06BX103K | 81349 | 56289 |
| C2 | Same as C1 | | | | |
| C3 | Capacitor, Electrolytic, Tantalum: 15 μ F, 20%, 15 V | 1 | 196D156X0015JA3 | 56289 | |
| C4 | Capacitor, Mica Dipped: 250 pF, 5%, 500 V | 1 | DM15-251J | 72136 | |
| C5 | Capacitor, Mica Dipped: 560 pF, 5%, 300 V | 1 | DM15-561J | 72136 | |
| L1 | Coil, Variable: 1.35-1.65 μ H | 1 | 558-7107-15 | 71279 | |
| Q1 | Transistor | 1 | 2N2857/JAN | 80131 | 02735 |
| R1 | Resistor, Fixed, Film: 5.62 k Ω , 1%, 1/10 W | 1 | RN55C5621F | 81349 | 75042 |
| R2 | Resistor, Fixed, Film: 2.21 k Ω , 1%, 1/10 W | 1 | RN55C2211F | 81349 | 75042 |
| R3 | Resistor, Fixed, Film: 3.92 k Ω , 1%, 1/10 W | 1 | RN55C3921F | 81349 | 75042 |
| R4 | Resistor, Fixed, Film: 274 Ω , 1%, 1/10 W | 1 | RN55C2740F | 81349 | 75042 |
| R5 | Resistor, Fixed, Film: 150 Ω , 1%, 1/10 W | 1 | RN55C1500F | 81349 | 75042 |
| R6 | Resistor, Fixed, Composition: 10 Ω , 5%, 1/4 W | 1 | RCR07G100JS | 81349 | 01121 |
| R7 | Resistor, Fixed, Film: 1.0 k Ω , 1%, 1/10 W | 1 | RN55C1001F | 81349 | 75042 |
| R8 | Resistor, Fixed, Composition: 22 Ω , 5%, 1/4 W | 1 | RCR07G220JS | | |
| R9 | Resistor, Fixed, Composition: 2.7 Ω , 5%, 1/4 W | 1 | RCR07G2R7JS | | |

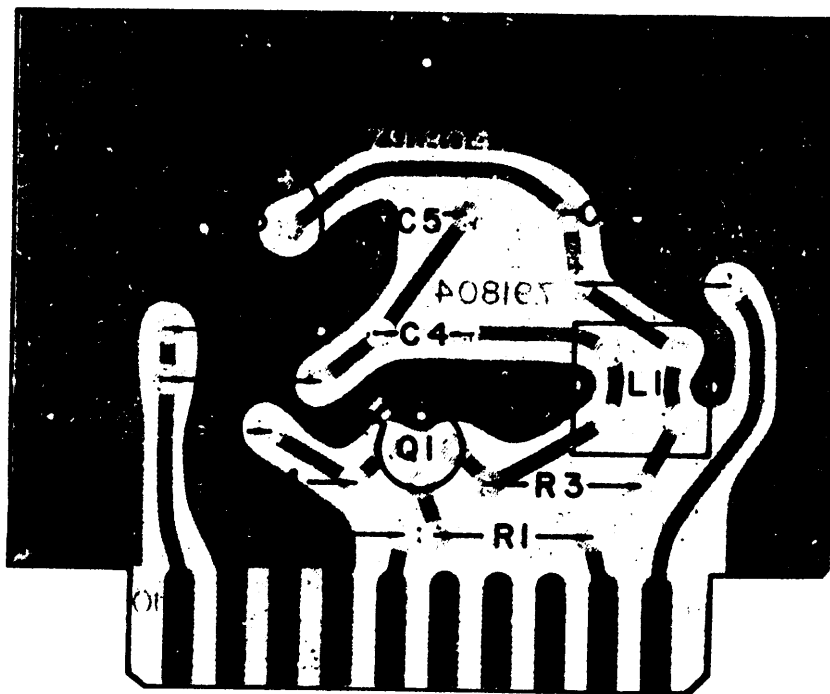


Figure 5-16. Type 791804-110 MHz Amplifier (A4A5),
Location of Components

REPLACEMENT PARTS LIST

TM 11-5895-1227-14-1

5.5.3.6 Type 791790 AM Detector/Buffer

REF DESIG PREFIX A4A6

| REF DESIG | DESCRIPTION | QTY PER ASSY | MANUFACTURER'S PART NO. | MFR. CODE | RECM VENDOR |
|--------------|--|--------------------|----------------------------|--------------|----------------|
| C1 | Capacitor, Ceramic, Disc: 0.01 μ F, 10%, 200 V | 9 | CK06BX103K | 81349 | 56289 |
| C2 | Same as C1 | | | | |
| C3 | Same as C1 | | | | |
| C4 | Capacitor, Variable, Ceramic: 5-25 pF, 100 V (N750) | 2 | 518-000A5-25 | 72982 | |
| C5 | Capacitor, Mica, Dipped: 62 pF, 2%, 500 V | 2 | CM04ED620G03 | 81349 | 72136 |
| C6 | Capacitor, Mica, Dipped: 10 pF \pm 0.5 pF, 500 V | 1 | CM05CD100D03 | 81349 | 72136 |
| C7 | Capacitor, Electrolytic, Tantalum: 15 μ F, 20%, 15 V | 3 | 196D156X0015JA1 | 56289 | |
| C8 | Same as C1 | | | | |
| C9 | Same as C1 | | | | |
| C10 | Same as C7 | | | | |
| C11 | Same as C7 | | | | |
| C12 | Same as C1 | | | | |
| C13 | Same as C1 | | | | |
| C14 | Capacitor, Mica, Dipped: 330 pF, 2%, 500 V | 1 | CM05FD331G03 | 81349 | 72136 |
| C15 | Same as C1 | | | | |
| C16 | Same as C1 | | | | |
| C17 | Same as C5 | | | | |
| C18 | Same as C4 | | | | |
| CR1 | Diode | 1 | 1N198A | 80131 | 93332 |
| Q1 | Transistor | 3 | 2N2857/JAN | 80131 | 02735 |
| Q2 | Transistor | 1 | 2N3251 | 80131 | 04713 |
| Q3 | Transistor | 1 | 2N2222A | 80131 | 04713 |
| Q4 | Same as Q1 | | | | |
| Q5 | Same as Q1 | | | | |
| R1 | Resistor, Fixed, Film: 3.32 k Ω , 1%, 1/10 W | 2 | RN55C3321F | 81349 | 75042 |
| R2 | Resistor, Fixed, Film: 1.1 k Ω , 1%, 1/10 W | 3 | RN55C1101F | 81349 | 75042 |
| R3 | Resistor, Fixed, Film: 1.5 k Ω , 1%, 1/10 W | 2 | RN55C1501F | 81349 | 75042 |
| R4 | Resistor, Fixed, Film: 121 Ω , 1%, 1/10 W | 2 | RN55C1210F | 81349 | 75042 |
| R5 | Resistor, Fixed, Film: 5.62 k Ω , 1%, 1/10 W | 3 | RN55C5621F | 81349 | 75042 |
| R6 | Resistor, Fixed, Film: 22.1 k Ω , 1%, 1/10 W | 1 | RN55C2212F | 81349 | 75042 |
| R7 | Resistor, Fixed, Film: 47.5 k Ω , 1%, 1/10 W | 2 | RN55C4752F | 81349 | 75042 |
| R8 | Resistor, Fixed, Film: 100 Ω , 1%, 1/10 W | 3 | RN55C1000F | 81349 | 75042 |
| R9 | Same as R5 | | | | |
| R10 | Resistor, Fixed, Film: 2.21 k Ω , 1%, 1/10 W | 1 | RN55C2211F | 81349 | 75042 |
| R11 | Resistor, Fixed, Film: 562 Ω , 1%, 1/10 W | 1 | RN55C5620F | 81349 | 75042 |
| R12 | Resistor, Fixed, Film: 182 Ω , 1%, 1/10 W | 1 | RN55C1820F | 81349 | 75042 |

REF DESIG PREFIX A4A6

| REF DESIG | DESCRIPTION | QTY. PER ASSY. | MANUFACTURER'S PART NO. | MFR. CODE | RECM. VENDOR |
|-----------|--|----------------|-------------------------|-----------|--------------|
| R13 | Same as R7 | | | | |
| R14 | Same as R8 | | | | |
| R15 | Resistor, Fixed, Film: 221 Ω , 1%, 1/10 W | 2 | RN55C2210F | 81349 | 75042 |
| R16 | Same as R2 | | | | |
| R17 | Same as R15 | | | | |
| R18 | Same as R8 | | | | |
| R19 | Resistor, Fixed, Film: 100 k Ω , 1%, 1/10 W | 1 | RN55C1003F | 81349 | 75042 |
| R20 | Same as R1 | | | | |
| R21 | Same as R2 | | | | |
| R22 | Same as R3 | | | | |
| R23 | Same as R4 | | | | |
| R24 | Same as R5 | | | | |
| T1 | Transformer | 2 | 21427-50 | 14632 | |
| T2 | Transformer | 1 | 21428-19 | 14632 | |
| T3 | Same as T1 | | | | |

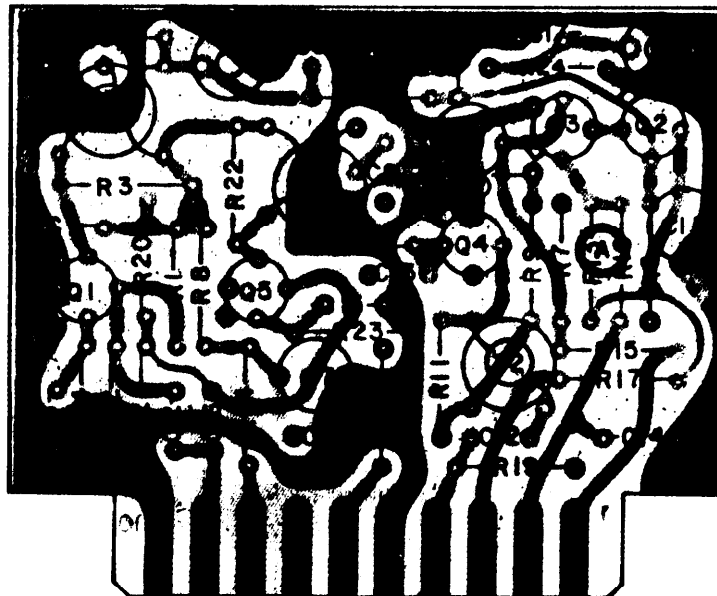


Figure 5-17. Type 791790 AM Detector/Buffer (A4A6), Location of Components

REPLACEMENT PARTS LIST

TM 11-5895-1227-14-1

5.5.3.7 Type 791785 Product Detector

REF DESIG PREFIX A4A7

| REF DESIG | DESCRIPTION | QTY PER ASSY | MANUFACTURER'S PART NO. | MFR. CODE | RECM VENDOR |
|--------------|--|--------------------|----------------------------|--------------|----------------|
| C1 | Capacitor, Electrolytic, Tantalum: 15 μ F, 20%, 15 V | 3 | 196D156X0015JA1 | 56289 | |
| C2 | Capacitor, Ceramic, Disc: 0.01 μ F, 10%, 200 V | 6 | CK06BX103K | 81349 | 56289 |
| C3 | Capacitor, Mica, Dipped: 27 pF, 2%, 500 V | 2 | CM04ED270G03 | 81349 | 72136 |
| C4 | Same as C3 | | | | |
| C5 | Same as C2 | | | | |
| C6 | Same as C2 | | | | |
| C7 | Capacitor, Ceramic, Disc: 0.47 μ F, 20%, 100 V | 2 | 8131M100-651474M | 72982 | |
| C8 | Same as C2 | | | | |
| C9 | Same as C2 | | | | |
| C10 | Same as C1 | | | | |
| C11 | Same as C7 | | | | |
| C12 | Same as C1 | | | | |
| C13 | Capacitor, Variable, Ceramic: 5-25 pF, 100 V, NPO | 1 | 518-000A5-25 | 72982 | |
| C14 | Same as C2 | | | | |
| Q1 | Transistor | 2 | 2N2857/JAN | 80131 | 02735 |
| Q2 | Same as Q1 | | | | |
| R1 | Resistor, Fixed, Film: 100 k Ω , 1%, 1/10 W | 2 | RN55C1003F | 81349 | 75042 |
| R2 | Same as R1 | | | | |
| R3 | Resistor, Fixed, Film: 1.0 k Ω , 1%, 1/10 W | 2 | RN55C1001F | 81349 | 75042 |
| R4 | Resistor, Fixed, Film: 100 Ω , 1%, 1/10 W | 5 | RN55C1000F | 81349 | 75042 |
| R5 | Same as R3 | | | | |
| R6 | Resistor, Fixed, Film: 562 Ω , 1%, 1/10 W | 1 | RN55C5620F | 81349 | 75042 |
| R7 | Resistor, Fixed, Film: 475 Ω , 1%, 1/10 | 1 | RN55C4750F | 81349 | 75042 |
| R8 | Resistor, Fixed, Composition: 51 Ω , 5%, 1/4 W | 1 | RCR07G510JS | 81349 | 01121 |
| R9 | Resistor, Fixed, Film: 8.06 k Ω , 1%, 1/10 W | 2 | RN55C8061F | 81349 | 75042 |
| R10 | Same as R9 | | | | |
| R11 | Resistor, Fixed, Film: 22.1 k Ω , 1%, 1.10 W | 2 | RN55C2212F | 81349 | 75042 |
| R12 | Same as R11 | | | | |
| R13 | Same as R4 | | | | |
| R14 | Resistor, Fixed, Film: 3.92 k Ω , 1%, 1/10 W | 2 | RN55C3921F | 81349 | 75042 |
| R15 | Resistor, Fixed, Film: 14 k Ω , 1%, 1/10 W | 1 | RN55C1402F | 81349 | 75042 |
| R16 | Same as R14 | | | | |
| R17 | Resistor, Fixed, Film: 20 k Ω , 1%, 1/10 W | 2 | RN55C2002F | 81349 | 75042 |
| R18 | Same as R17 | | | | |
| R19 | Resistor, Fixed, Film: 61.9 k Ω , 1%, 1/4 W | 1 | RN60D6192 | 81349 | 75042 |
| R20 | Resistor, Fixed, Film: 10 Ω , 5%, 1/4 W | 1 | CC10ROF | 81349 | 01121 |

REF DESIG PREFIX A4A7

| REF DESIG | DESCRIPTION | QTY. PER ASSY. | MANUFACTURER'S PART NO. | MFR. CODE | RECM. VENDOR |
|-----------|-------------------------|----------------|-------------------------|-----------|--------------|
| R21 | Same as R4 | | | | |
| R22 | Same as R4 | | | | |
| R23 | Same as R4 | | | | |
| T1 | Transformer | 1 | 21428-19 | 14632 | |
| U1 | Integrated Circuit | 1 | MC1596L | 04713 | |
| U2 | Integrated Circuit | 1 | 741HM | 07263 | |
| Y1 | Crystal, Quartz: 10 MHz | 1 | CR64U | 80058 | 74306 |

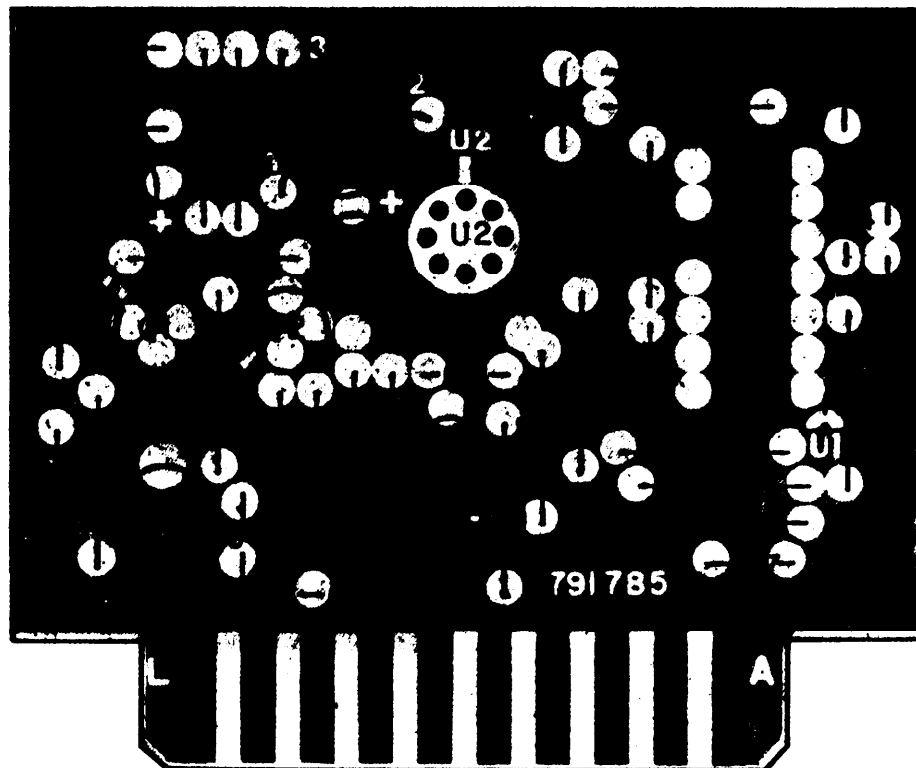


Figure 5-18. Type 791785 Product Detector (A4A7), Location of Components

FIGURE 5-19

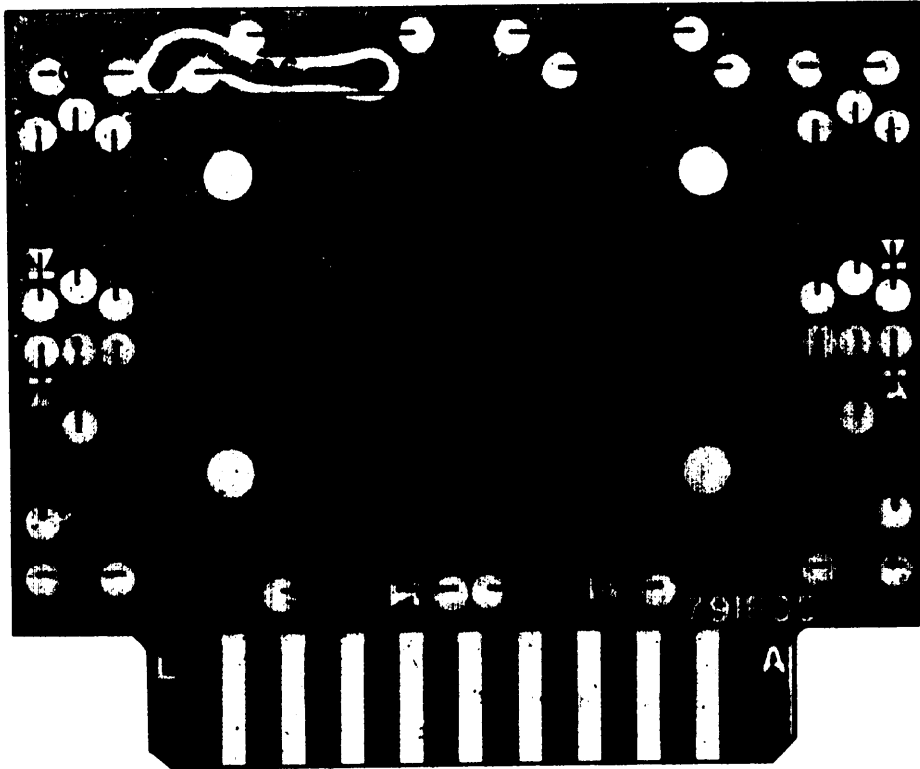


Figure 5-19. Type 791805 LSB/USB Filters (A4A9),
Location of Components

TM 11-5895-1227-14-1

REPLACEMENT PARTS LIST

5.5.3.8 Type 791805 LSB/USB Filters

REF DFSIG PREFIX A4A9

| REF DESIG | DESCRIPTION | QTY PER ASSY | MANUFACTURER'S PART NO. | MFR. CODE | RECM VENDOR |
|--------------------|---|--------------------|----------------------------|--------------|----------------|
| C1 | Capacitor, Ceramic, Disc: 0.01 μ F, 10%, 200 V | 6 | CK06BX103K | 81349 | 56289 |
| C2 Thru C6 | Same as C1 | | | | |
| CR1 | Diode | 4 | MPN3401 | 80131 | 93332 |
| CR2 Thru CR4 | Same as CR1 | | | | |
| CR5 | Diode | 2 | IN4449 | | |
| CR6 | Same as CR5 | | | | |
| FL1 | Filter | 1 | 92157 | 14632 | |
| K1 | Relay | 1 | 712-12 | | |
| L1 | Coil, Fixed: 47 μ H, 10% | 2 | 1025-60 | | |
| L2 | Same as L1 | | | | |
| R1 | Resistor, Fixed, Film: 100 k Ω , 1%, 1/10 W | 5 | RN55C1002F | 81349 | 75042 |
| R2 | Same as R1 | | | | |
| R3 | Same as R1 | | | | |
| R4 | Resistor, Fixed, Film: 33.2 k Ω , 1%, 1/10 W | 4 | RN55C3322F | 81349 | 75042 |
| R5 | Same as R4 | | | | |
| R6 | Same as R4 | | | | |
| R7 | Same as R4 | | | | |
| R8 | Same as R1 | | | | |
| R9 | Same as R1 | | | | |
| R10 | Resistor, Fixed, Film: 221 Ω , 1%, 1/10 W | 1 | RN55C2210F | 81349 | 75042 |

FIGURE 5-20

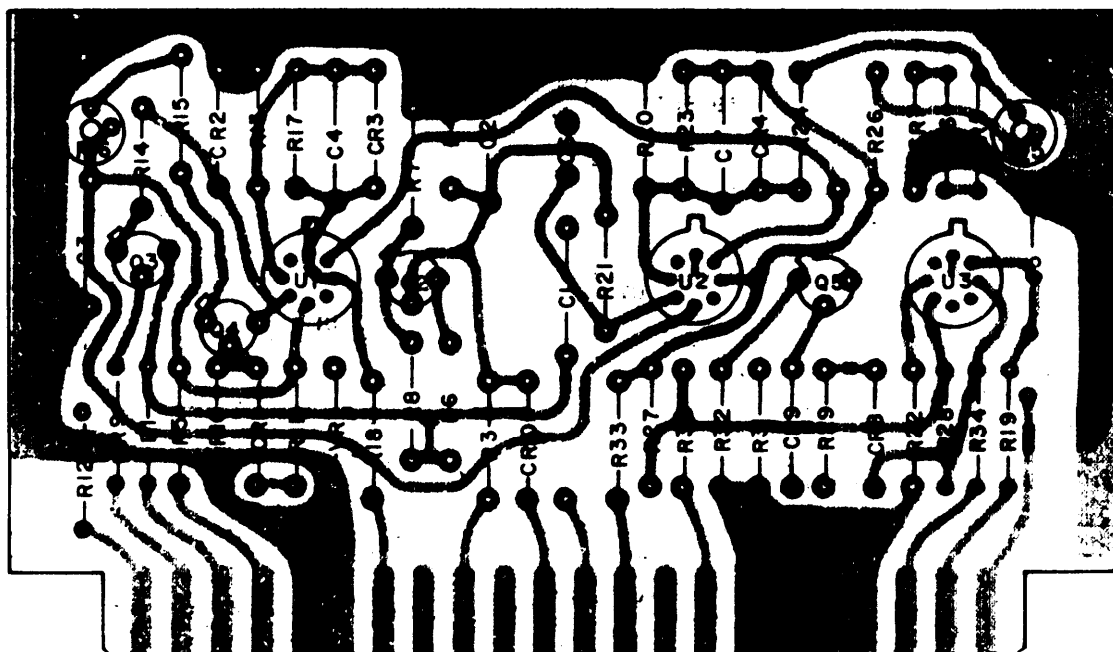


Figure 5-20. Type 791817 AGC Schuelch (A5),
Location of Components

TM 11-5895-1227-14-1

REPLACEMENT PARTS LIST

5.5.4 TYPE 791817 AGC SQUELCH

REF DESIG PREFIX AS

| REF DESIG | DESCRIPTION | QTY PER ASSY | MANUFACTURER'S PART NO. | MFR. CODE | RECM VENDOR |
|--------------------|---|--------------------|----------------------------|--------------|----------------|
| C1 | Capacitor, Electrolytic, Tantalum: 1.0 μ F, 10%, 35 V | 5 | CS13BF105K | 81349 | 56289 |
| C2 | Capacitor, Electrolytic, Tantalum: 15 μ F, 20%, 15 V | 1 | CS13BE156K | 56289 | |
| C3 Thru C5 | Same as C1 | | | | |
| C6 | Capacitor, Ceramic, Disc: 0.01 μ F, 10%, 200 V | 1 | CK06BX103K | 81349 | 56289 |
| C7 | Same as C1 | | | | |
| CR1 | Diode | 6 | 1N4449 | 80131 | 93332 |
| CR2 Thru CR4 | Same as CR1 (CR5, CR6, and CR7 are type 1N198A) | | | | |
| CR5 | Diode | 4 | 1N198A | | |
| CR6 | Same as CR5 | | | | |
| CR7 | Same as CR5 | | | | |
| CR8 | Same as CR1 | | | | |
| CR9 | Same as CR1 | | | | |
| CR10 | Same as CR5 | | | | |
| Q1 | Not Used | | | | |
| Q2 | Transistor | 3 | 2N2222A | 80131 | 04713 |
| Q3 | Transistor | 1 | 2N930 | 80131 | |
| Q4 | Same as Q2 | | | | |
| Q5 | Same as Q2 | | | | |
| R1 | Resistor, Fixed, Film: 100 Ω , 1%, 1/10 W | 4 | RN55C1000F | 81349 | 75042 |
| R2 | Not Used | | | | |
| R3 | Resistor, Fixed, Film: 51.1 k Ω , 1%, 1/10 W | 1 | RN55C5112F | 81349 | 75042 |
| R4 | Resistor, Fixed, Film: 332 k Ω , 1%, 1/4 W | 1 | MF4C332KF | 80031 | |
| R5 | Same as R1 | | | | |
| R6 | Resistor, Fixed, Film: 100 k Ω , 1%, 1/10 W | 6 | RN55C1003F | 81349 | 75042 |
| R7 | Resistor, Fixed, Film: 3.32 k Ω , 1%, 1/10 W | 2 | RN55C3321F | 81349 | 75042 |
| R8 | Resistor, Fixed, Film: 48.7 k Ω , 1%, 1/10 W | 1 | RN55C4872F | 81349 | 75042 |
| R9 | Resistor, Fixed, Film: 1.21 k Ω , 1%, 1/10 W | 1 | RN55C1211F | 81349 | 75042 |
| R10 | Resistor, Fixed, Film: 1.0 M Ω , 1%, 1/4 W | 1 | CC1004F | 01121 | |
| R11 | Resistor, Fixed, Film: 97.6 k Ω , 1%, 1/10 W | 1 | RN55C9762F | 81349 | 75042 |
| R12 | Resistor, Fixed, Composition: 10 Ω , 5%, 1/4 W | 1 | RCR07G100JS | 81349 | 75042 |
| R13 | Resistor, Fixed, Film: 10 k Ω , 1%, 1/10 W | 5 | RN55C1002F | 81349 | 75042 |
| R14 | Resistor, Fixed, Film: 33.2 k Ω , 1%, 1/10 W | 2 | RN55C3322F | 81349 | 75042 |
| R15 | Same as R7 | | | | |
| R16 | Resistor, Trimmer, Film: 5 k Ω , 10%, 1/2 W | 1 | 62PR5K | 73138 | |
| R17 | Same as R6 | | | | |
| R18 | Resistor, Fixed, Film: 2.21 k Ω , 1%, 1/10 W | 1 | RN55C2211F | 81349 | 75042 |
| R19 | Same as R1 | | | | |
| R20 | Same as R14 | | | | |
| R21 | Same as R6 | | | | |

REF DESIG PREFIX A5

| REF DESIG | DESCRIPTION | QTY PER ASSY | MANUFACTURER'S PART NO. | MFR. CODE | RECM VENDOR |
|--------------|---|--------------------|----------------------------|--------------|----------------|
| R22 | Same as R13 | | | | |
| R23 | Same as R6 | | | | |
| R24 | Same as R13 | | | | |
| R25 | Resistor, Trimmer, Film: 100 k Ω , 10%, 1/2 W | 1 | 62PR100K | 73138 | |
| R26 | Same as R13 | | | | |
| R27 | Same as R6 | | | | |
| R28 | Resistor, Fixed, Composition: 22 M Ω , 5%, 1/4 W | 1 | RCR07G226JS | 81349 | 01121 |
| R29 | Resistor, Fixed, Film: 13.3 k Ω , 1%, 1/10 W | 1 | RN55C1332F | 81349 | 75042 |
| R30 | Same as R17 | | | | |
| R31 | Resistor, Fixed, Film: 1.0 k Ω , 1%, 1/10 W | 1 | RN55C1001F | 81349 | 75042 |
| R32 | Same as R1 | | | | |
| R33 | Resistor, Fixed, Film: 127 k Ω , 1%, 1/4 W | 1 | MF4C127KF | 80031 | |
| R34 | Same as R13 | | | | |
| U1 | Integrated Circuit | 3 | 741HM | 07263 | |
| U2 | Same as U1 | | | | |
| U3 | Same as U1 | | | | |
| VR1 | Diode Zener 8.2 Silicon | 1 | 1N756A | 04713 | |

5.5.5 TYPE 791794 DC- DC CONVERTER

REF DESIG PREFIX A6

| REF DESIG | DESCRIPTION | QTY. PER ASSY. | MANUFACTURER'S PART NO. | MFR. CODE | RECM. VENDOR |
|------------------|---|----------------------|----------------------------|--------------|-----------------|
| A1 | DC-DC Converter Board | 1 | 24998-1 | 14632 | |
| C1 | Capacitor, Ceramic, Feedthru: 470 pF, 20%, 500 V | 6 | 54-794-009-471M | 33095 | |
| C2 Thru C6 | Same as C1 | | | | |
| C7 | Capacitor, Electrolytic, Tantalum: 220 μ F, 20%, 10 V | 1 | 196D227X0010TE4 | 56289 | |
| P1 | Connector, Plug: SRE Series | 1 | SRE14PNSS | 81312 | |
| Q1 | Transistor | 2 | 2N3054 | 80131 | 02735 |
| Q2 | Same as Q1 | | | | |
| R1 | Resistor, Fixed, Film: 100 k Ω , 1%, 1/10 W | 2 | RN55C1003F | 81349 | 75042 |
| R2 | Same as R1 | | | | |

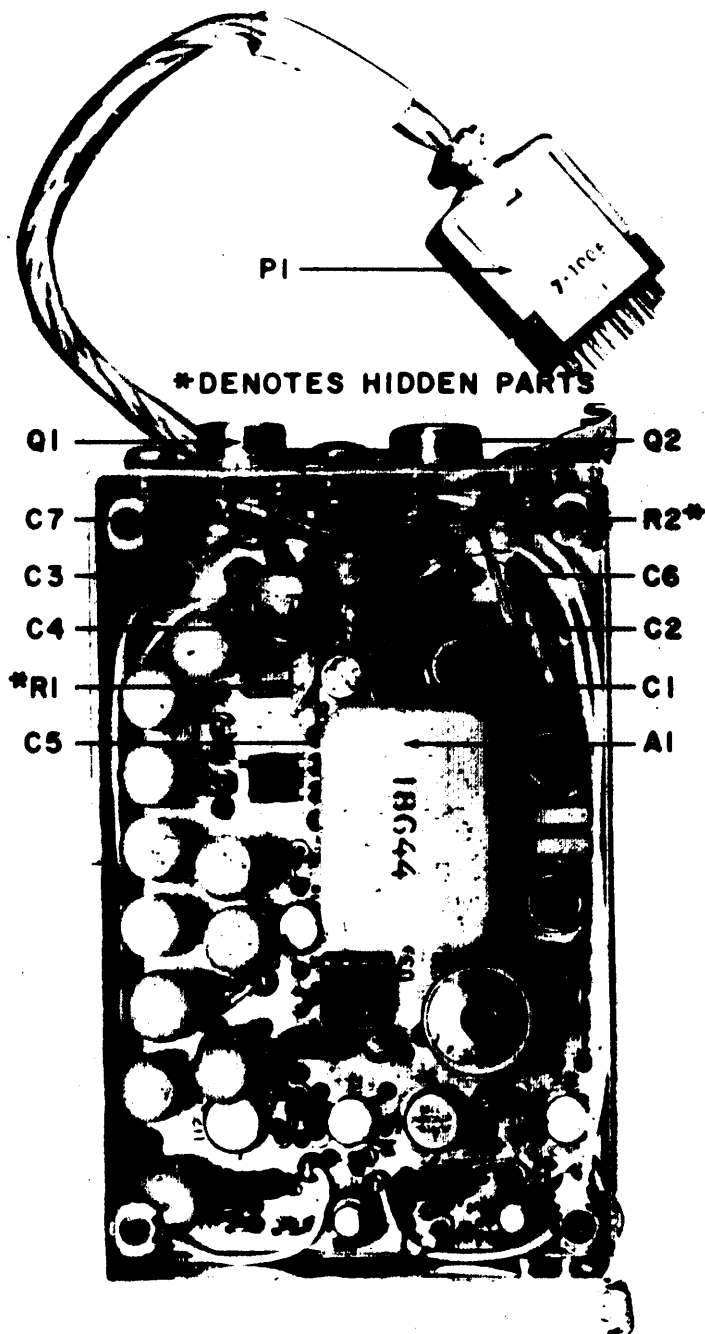


Figure 5-21. Type 791794 DC-DC Converter (A6),
Location of Components

5.5.5.1 Part 24998-1 DC-DC Converter Board

REF DESIG PREFIX A6A1

| REF DESIG | DESCRIPTION | QTY. PER ASSY. | MANUFACTURER'S PART NO. | MFR. CODE | RECM. VENDOR |
|--------------------|---|----------------------|----------------------------|--------------|-----------------|
| C1 | Capacitor, Electrolytic, Tantalum: 100 μ F, 20%, 20 V | 8 | 196D107X0020TE4 | 56289 | |
| C2 | Same as C1 | | | | |
| C3 | Same as C1 | | | | |
| C4 | Same as C1 | | | | |
| C5 | Capacitor, Mica, Dipped: 330 pF, 2%, 500 V | 3 | CM05FD331G03 | 81349 | 72136 |
| C6 | Same as C5 | | | | |
| C7 | Capacitor, Electrolytic, Tantalum: 2.2 μ F, 20%, 35 V | 2 | 196D225X0035JE3 | 56289 | |
| C8 | Same as C5 | | | | |
| C9 | Same as C7 | | | | |
| C10 | Capacitor, Electrolytic, Tantalum: 220 μ F, 20%, 10 V | 4 | 196D227X0010TE4 | 56289 | |
| C11 | Same as C10 | | | | |
| C12 | Capacitor, Ceramic, Disc: 0.01 μ F, 10%, 200 V | 2 | CK06BX103K | 81349 | 56289 |
| C13 | Same as C12 | | | | |
| C14 Thru C17 | Same as C1 | | | | |
| C18 | Same as C10 | | | | |
| C19 | Same as C10 | | | | |
| CR1 | Diode | 3 | 1N4446 | 80131 | 93332 |
| CR2 | Same as CR1 | | | | |
| CR3 | Same as CR1 | | | | |
| E1 | Terminal, Forked | 9 | 140-1941-02-01 | 71279 | |
| E2 Thru E9 | Same as E1 | | | | |
| Q1 | Transistor | 2 | 2N3251 | 80131 | 04713 |
| Q2 | Same as Q1 | | | | |
| Q3 | Transistor | 2 | 2N4239 | 80131 | 02735 |
| Q4 | Same as Q3 | | | | |
| R1 | Resistor, Fixed, Composition: 47 Ω , 5%, 1/4 W | 3 | RCR07G470JS | 81349 | 01121 |
| R2 | Resistor, Fixed, Film: 1.1 k Ω , 1%, 1/10 W | 4 | RN55C1101F | 81349 | 75042 |
| R3 | Same as R2 | | | | |
| R4 | Same as R2 | | | | |
| R5 | Same as R2 | | | | |
| R6 | Resistor, Fixed, Film: 619 k Ω , 1%, 1/4 W | 2 | CC6193F | 01121 | |
| R7 | Same as R6 | | | | |
| R8 | Resistor, Fixed, Film: 10 K Ω , 1%, 1/10 W | 4 | RN55C1002F | 81349 | 75042 |

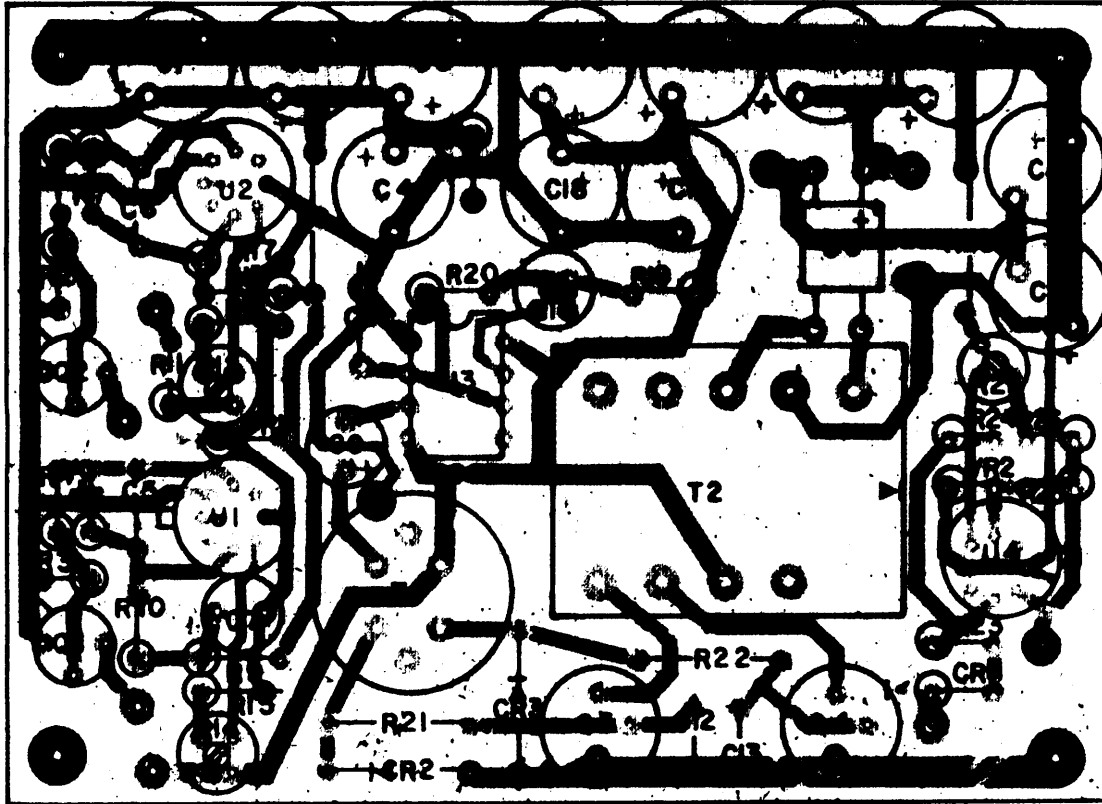


Figure 5-22. Part 24998-1 DC-DC Converter Board (A6A1),
Location of components

REF DESIG PREFIX A6A1

| REF DESIG | DESCRIPTION | QTY. PER ASSY. | MANUFACTURER'S PART NO. | MFR. CODE | RECM. VENDOR |
|--------------|---|----------------------|----------------------------|--------------|-----------------|
| R9 | Resistor, Fixed, Film: 2.21 k Ω , 1%, 1/10 W | 2 | RN55C2211F | 81349 | 75042 |
| R10 | Same as R9 | | | | |
| R11 | Same as R8 | | | | |
| R12 | Resistor, Trimmer, Film: 5 k Ω , 10%, 1/2 W | 2 | 62PR5K | 73138 | |
| R13 | Resistor, Fixed, Film: 15 k Ω , 1%, 1/10 W | 2 | RN55C1502F | 81349 | 75042 |
| R14 | Resistor, Trimmer, Film: 10 k Ω , 10%, 1/2 W | 1 | 62PR10K | 73138 | |
| R15 | Same as R13 | | | | |
| R16 | Resistor, Fixed, Film: 22.1 k Ω , 1%, 1/10 W | 3 | RN55C2212F | 81349 | 75042 |
| R17 | Same as R16 | | | | |
| R18 | Resistor, Trimmer, Film: 1 k Ω , 10%, 1/2 W | 1 | 62PR1K | 73138 | |
| R19 | Same as R8 | | | | |
| R20 | Resistor, Fixed, Film: 90.9 k Ω , 1%, 1/10 W | 1 | RN55C9092F | 81349 | 75042 |
| R21 | Same as R1 | | | | |
| R22 | Same as R1 | | | | |
| R23 | Resistor, Fixed, Film: 3.32 k Ω , 1%, 1/10 W | 1 | RN55C3321F | 81349 | 75042 |
| R24 | Resistor, Fixed, Film: 1 M Ω , 1%, 1/4 W | 1 | CC1004F | 01121 | |
| R25 | Same as R16 | | | | |
| R26 | Resistor, Fixed, Film: 4.75 k Ω , 1%, 1/10 W | 1 | RN55C4751F | 81349 | 75042 |
| R27 | Same as R12 | | | | |
| R28 | Same as R8 | | | | |
| T1 | Transformer | 1 | 30312-268 | 14632 | |
| T2 | Transformer | 1 | 18644 | 14632 | |
| U1 | Integrated Circuit | 3 | 741HC | 07263 | |
| U2 | Same as U1 | | | | |
| U3 | Integrated Circuit | 1 | SE555V | 18324 | |
| U4 | Same as U1 | | | | |
| U5 | Rectifier Assembly | 1 | MDA920A3 | 04713 | |
| VR1 | Diode Zener 6.8 V Silicon | 2 | 1N754A | 80131 | 04713 |
| VR2 | Same as VR1 | | | | |

FIGURE 5-23

TM 11-5895-1227-14-1

5.5.6.1 TYPE 791784 FM DISCRIMINATOR ASSEMBLY

REF DESIG PREFIX A7

| REF DESIG | DESCRIPTION | QTY PER ASSY | MANUFACTURER'S PART NO. | MFR. CODE | RECM VENDOR |
|--------------|--|--------------------|----------------------------|--------------|----------------|
| A1 | FM Discriminator Board | 1 | 24925 | 14632 | |
| C1 | Capacitor, Ceramic, Feedthru: 470 pF, 20%, 500 V | 2 | 54-794-009-471M | 33095 | |
| C2 | Capacitor, Ceramic, Feedthru: 33 pF, 10%, 500 V | 1 | 54-794-001-3301 | 33095 | |
| C2 | Same as C1 | | | | |
| J1 | Connector, Receptacle: SMC Series | 1 | 10-0104-002 | 19505 | |
| P1 | Connector, Plug: SRE Series | 1 | SRE7PNSS | 81312 | |
| R1 | Resistor, Fixed, Composition: 4.7 kΩ, 5%, 1/4 W | 1 | RCR07G472JS | | |
| R2 | Resistor, Fixed, Composition: 10 kΩ, 5%, 1/4 W | 1 | RCR07G103JS | | |

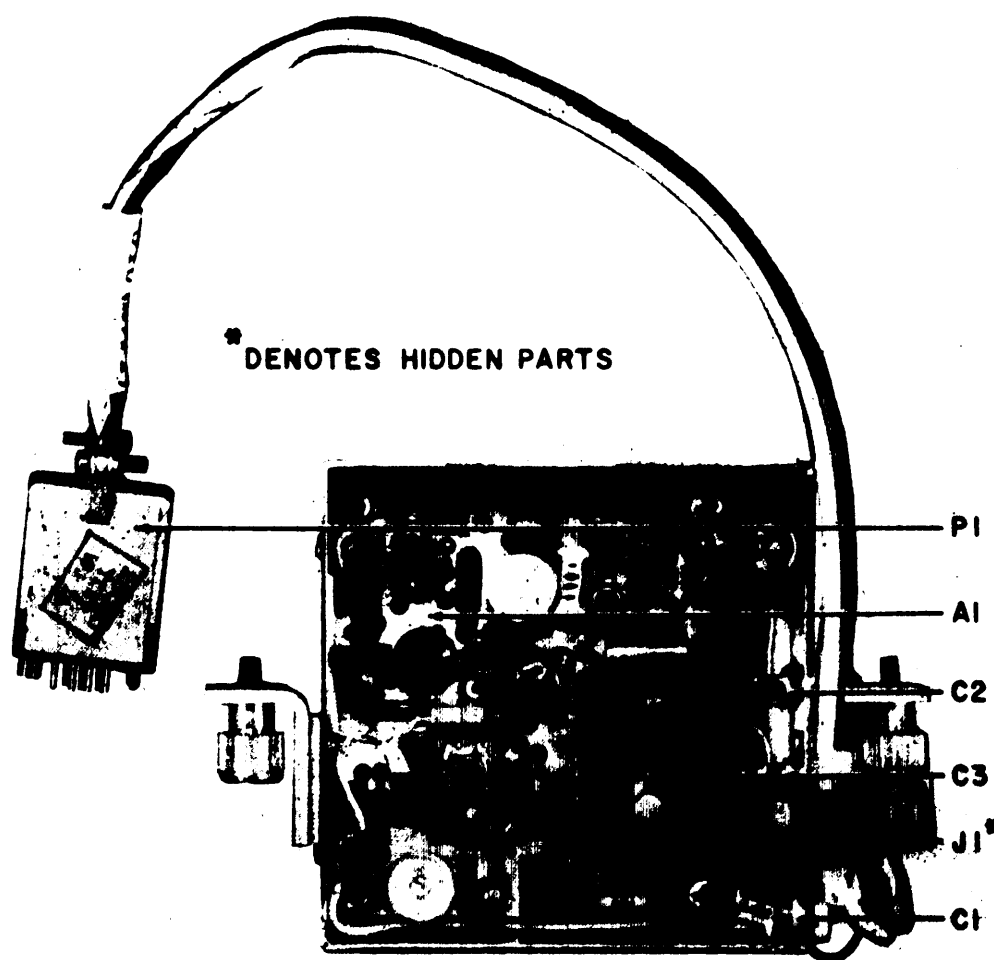


Figure 5-23. Type 791784 FM Discriminator Assembly (A7),
Location of Components

5.5.6.1 Part 24925 M Discriminator Board

REF DESIG PREFIX A7AI

| REF DESIG | DESCRIPTION | QTY PER ASSY | MANUFACTURER'S PART NO. | MFR. CODE | RECM VENDOR |
|--------------|--|--------------------|----------------------------|--------------|----------------|
| C1 | Capacitor, Electrolytic, Tantalum: 15 μ F, 20%, 15 V | 4 | 195D156X0015JA1 | 56289 | |
| C2 | Capacitor, Ceramic, Disc: 0.01 μ F, 10%, 200 V | 11 | CK06BX103K | 81349 | 56289 |
| C3 | Capacitor, Mica, Dipped: 150 pF, 2%, 500 V | 2 | CM05FD151G03 | 81349 | 56289 |
| C4 | Same as C2 | | | | |
| C5 | Same as C1 | | | | |
| C6 | Same as C2 | | | | |
| C7 | Same as C2 | | | | |
| C8 | Same as C2 | | | | |
| C9 | Same as C2 | | | | |
| C10 | Capacitor, Mica, Dipped: 10 pF \pm 0.5 pF, 500 V | 2 | CM05CD100D03 | 81349 | 72136 |
| C11 | Same as C2 | | | | |
| C12 | Capacitor, Variable, Ceramic: 5.5-18 pF, 350 V | 2 | 538-011A5.5-18 | 72982 | |
| C13 | Same as C2 | | | | |
| C14 | Same as C1 | | | | |
| C15 | Capacitor, Mica, Dipped: 18 pF, 5%, 500 V | 2 | CM05CD180J03 | 81349 | 72136 |
| C16 | Same as C15 | | | | |
| C17 | Same as C12 | | | | |
| C18 | Same as C1 | | | | |
| C19 | Same as C2 | | | | |
| C20 | Same as C10 | | | | |
| C21 | Capacitor, Electrolytic, Tantalum: 10 μ F, 10%, 20 V | 1 | CS13BF106K | 81349 | 56289 |
| C22 | Same as C2 | | | | |
| C23 | Capacitor, Mica, Dipped: 47 pF, 2%, 500 V | 1 | CM05ED470G03 | 81349 | 56289 |
| C24 | Capacitor, Ceramic, Tubular: 10 pF, \pm 0.5 pF, 500 V (N750) | 1 | 301-000U2J0100D | 72982 | |
| CR1 | Diode | 2 | 1N198A | 80131 | 93332 |
| CR2 | Same as CR1 | | | | |
| CR3 | Diode | 1 | 1N4446 | 80131 | 93332 |
| E1 | Terminal, Forked | 4 | 140-1941-02-01 | 71279 | |
| E2 | Same as E1 | | | | |
| E3 | Same as E1 | | | | |
| E4 | Same as E1 | | | | |
| L1 | Coil, Fixed | 1 | 20681-146 | 14632 | |
| Q1 | Transistor | 4 | 2N2857/JAN | 80131 | 02735 |
| Q2 | Same as Q1 | | | | |
| Q3 | Same as Q1 | | | | |

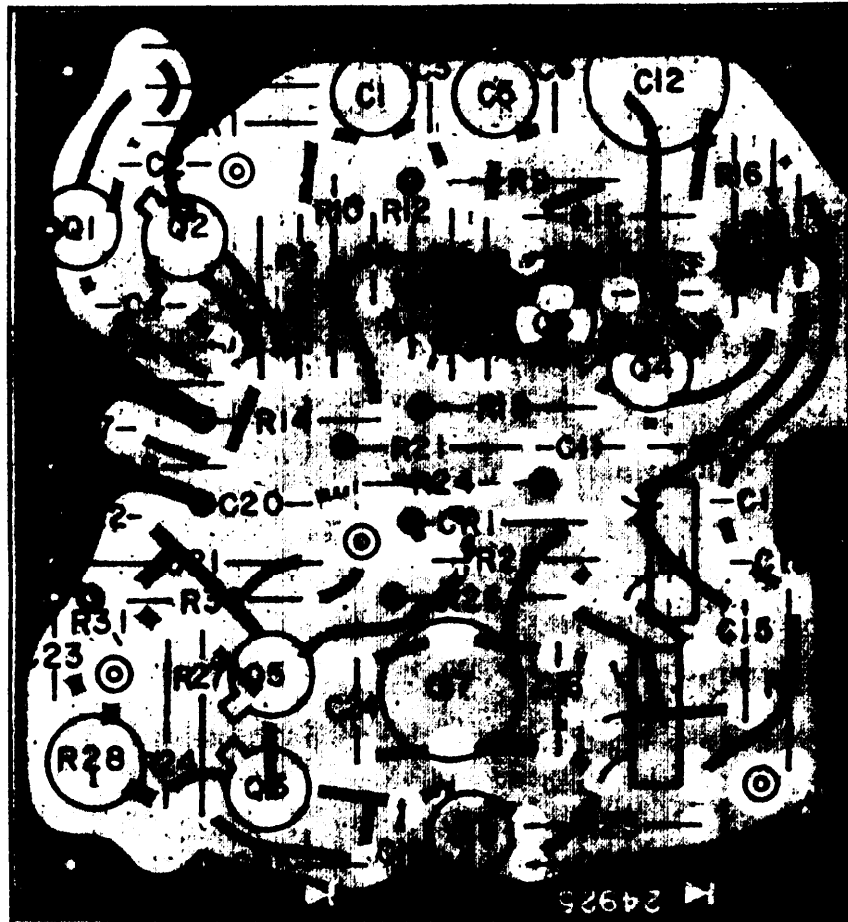


Figure 5-24. Part 24925 FM Discriminator Board (A7A1), Location of Components

REF DESIG PREFIX A7A1

| REF DESIG | DESCRIPTION | QTY PER ASSY | MANUFACTURER'S PART NO. | MFR. CODE | RECM VENDOR |
|--------------|--|--------------------|----------------------------|--------------|----------------|
| Q4 | Same as Q1 | | | | |
| Q5 | Transistor | 1 | 2N3251 | 80131 | 04713 |
| Q6 | Transistor | 1 | 2N2222A | 80131 | 04713 |
| R1 | Resistor, Fixed, Film: 9.09 k Ω , 1%, 1/10 W | 4 | RN55C9091F | 81349 | 75042 |
| R2 | Resistor, Fixed, Film: 4.75 k Ω , 1%, 1/10 W | 4 | RN55C4751F | 81349 | 75042 |
| R3 | Resistor, Fixed, Film: 1.3 k Ω , 1%, 1/10 W | 8 | RN55C1301F | 81349 | 75042 |
| R4 | Same as R3 | | | | |
| R5 | Same as R3 | | | | |
| R6 | Same as R3 | | | | |
| R7 | Same as R1 | | | | |
| R8 | Same as R2 | | | | |
| R9 | Resistor, Fixed, Film: 200 Ω , 1%, 1/10 W | 1 | RN55C2000F | 81349 | 75042 |
| R10 | Resistor, Fixed, Film: 49.9 Ω , 1%, 1/10 W | 4 | RN55C49R9F | 81349 | 75042 |
| R11 | Same as R1 | | | | |
| R12 | Same as R2 | | | | |
| R13 | Same as R3 | | | | |
| R14 | Same as R3 | | | | |
| R15 | Resistor, Fixed, Film: 100 Ω , 1%, 1/10 W | 2 | RN55C1000F | 81349 | 75042 |
| R16 | Resistor, Fixed, Film: 10.5 k Ω , 1%, 1/10 W | 1 | RN55C1052F | 81349 | 75042 |
| R17 | Same as R10 | | | | |
| R18 | Same as R3 | | | | |
| R19 | Same as R1 | | | | |
| R20 | Same as R2 | | | | |
| R21 | Same as R10 | | | | |
| R22 | Same as R10 | | | | |
| R23 | Same as R15 | | | | |
| R24 | Same as 3 | | | | |
| R25 | Resistor, Fixed, Film: 47.5 k Ω , 1%, 1/10 W | 2 | RN55C4752F | 81349 | 75042 |
| R26 | Resistor, Fixed, Film: 33.2 k Ω , 1%, 1/10 W | 1 | RN55C3322F | 81349 | 75042 |
| R27 | Same as R25 | | | | |
| R28 | Resistor, Trimmer, Film: 10 k Ω , 10%, 1/2 W | 1 | 62PR10K | 73138 | |
| R29 | Resistor, Fixed, Film: 3.32 k Ω , 1%, 1/10 W | 1 | RN55C3322F | 81349 | 75042 |
| R30 | Resistor, Fixed, Film: 332 Ω , 1%, 1/10 W | 1 | RN55C3320F | 81349 | 75042 |
| R31 | Resistor, Fixed, Composition: 4.7 k Ω , 5%, 1/4 W | 1 | RCR07G472JS | 81349 | 75042 |
| R32 | Resistor, Fixed, Film: 2.21 k Ω , 1%, 1/10 W | 1 | RN55C2211F | | |
| T1 | Transformer | 1 | 21427-43 | 14632 | |

REPLACEMENT PARTS LIST

TM 11-5895-1227-14-1

5.5.7 TYPE 7464-2 AUDIO AND RECORD AMPLIFIER

REF DESIG PREFIX A8

| REF DESIG | DESCRIPTION | QTY. PER ASSY. | MANUFACTURER'S PART NO. | MFR. CODE | RECM. VENDOR |
|--------------|---|----------------------|----------------------------|--------------|-----------------|
| C1 | Capacitor, Ceramic, Disc: 0.47 μ F, 20%, 100 V | 5 | 8131M100-651-474M | 72982 | |
| C2 | Capacitor, Mica, Dipped: 200 pF, 2%, 500 V | 1 | CM05FD201G03 | 81349 | 72136 |
| C3 | Capacitor, Electrolytic, Tantalum: 1.0 μ F, 10%, 35 V | 2 | CS13BF105K | 81349 | 72136 |
| C4 | Same as C1 | | | | |
| C5 | Capacitor, Mica, Dipped: 270 pF, 2%, 500 V | 1 | CM05FD271G03 | 81349 | 72136 |
| C6 | Same as C3 | | | | |
| C7 | Same as C1 | | | | |
| C8 | Same as C1 | | | | |
| C9 | Same as C1 | | | | |
| C10 | Capacitor, Electrolytic, Tantalum: 100 μ F, 10%, 20 V | 3 | CS13BE107K | 81349 | 56289 |
| C11 | Same as C10 | | | | |
| C12 | Same as C10 | | | | |
| CR1 | Diode | 3 | 1N4449 | 80131 | 93332 |
| CR2 | Same as CR1 | | | | |
| CR3 | Same as CR1 | | | | |
| Q1 | Transistor | 2 | U1899E | 15818 | |
| Q2 | Same as Q1 | | | | |
| Q3 | Transistor | 1 | 2N930 | 80131 | 04713 |
| Q4 | Transistor | 1 | 2N3251 | 80131 | 04713 |
| Q5 | Transistor | 1 | 2N2222A | 80131 | 04713 |
| Q6 | Transistor | 1 | JAN2N2907 | 81350 | 04713 |
| R1 | Resistor, Fixed, Film: 5.11 k Ω , 1%, 1/10 W | 1 | RN55C5111F | 81349 | 75042 |
| R2 | Resistor, Fixed, Film: 15 k Ω , 1%, 1/10 W | 2 | RN55C1502F | 81349 | 75042 |
| R3 | Resistor, Fixed, Film: 221 Ω , 1%, 1/10 W | 2 | RN55C2210F | 81349 | 75042 |
| R4 | Resistor, Fixed, Film: 110 k Ω , 1%, 1/4 W | 5 | MF4C110KF | 80031 | |
| R5 | Resistor, Fixed, Film: 332 k Ω , 1%, 1/4 W | 3 | MF4C332KF | 80031 | |
| R6 | Same as R5 | | | | |
| R7 | Same as R2 | | | | |
| R8 | Resistor, Fixed, Composition: 82 k Ω , 5%, 1/4 W | 1 | RCR07G823JS | 81349 | 01121 |
| R9 | Same as R4 | | | | |
| R10 | Resistor, Fixed, Film: 2.21 k Ω , 1%, 1/10 W | 2 | RN55C2211F | 81349 | 75042 |
| R11 | Resistor, Fixed, Film: 10.5 k Ω , 1%, 1/10 W | 1 | RN55C1052F | 81349 | 75042 |
| R12 | Same as R4 | | | | |
| R13 | Same as R4 | | | | |
| R14 | Same as R3 | | | | |
| R15 | Resistor, Fixed, Film: 511 Ω , 1%, 1/10 W | 1 | RN55C5110F | 81349 | 75042 |

REF DESIG PREFIX A8

| REF DESIG | DESCRIPTION | QTY. PER ASSY. | MANUFACTURER'S PART NO. | MFR. CODE | RECM. VENDOR |
|-----------|---|----------------|-------------------------|-----------|--------------|
| R16 | Resistor, Fixed, Film: 475 kΩ, 1%, 1/4 W | 1 | CC4753F | 01121 | |
| R17 | Same as R5 | | | | |
| R18 | Resistor, Fixed, Film: 1.21 kΩ, 1%, 1/10 W | 1 | RN55C1211F | 81349 | 75042 |
| R19 | Resistor, Fixed, Film: 48.7 kΩ, 1%, 1/10 W | 1 | RN55C4872F | 81349 | 75042 |
| R20 | Resistor, Fixed, Film: 40.2 kΩ, 1%, 1/10 W | 2 | RN55C4022F | 81349 | 75042 |
| R21 | Resistor, Fixed, Film: 3.92 kΩ, 1%, 1/10 W | 1 | RN55C3921F | 81349 | 75042 |
| R22 | Resistor, Fixed, Film: 150 Ω, 1%, 1/10 W | 1 | RN55C1500F | 81349 | 75042 |
| R23 | Resistor, Fixed, Film: 100 Ω, 1%, 1/10 W | 1 | RN55C1000F | 81349 | 75042 |
| R24 | Resistor, Fixed, Composition: 22 Ω, 5%, 1/4 W | 2 | RCR07G220JS | 81349 | 01121 |
| R25 | Same as R10 | | | | |
| R26 | Resistor, Fixed, Composition: 10 Ω, 5%, 1/4 W | 2 | RCR07G100JS | 81349 | 01121 |
| R27 | Same as R26 | | | | |
| R28 | Same as R20 | | | | |
| R29 | Same as R24 | | | | |
| R30 | Same as R4 | | | | |
| U1 | Integrated Circuit | 2 | 741HM | 97263 | |
| U2 | Same as U1 | | | | |

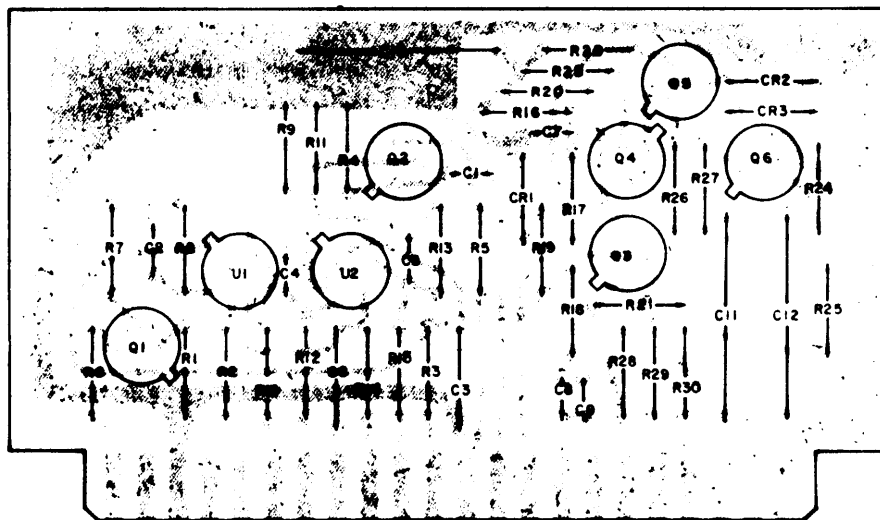


Figure 5-25. Type 7464-2 Audio & Record Amplifier (A8), Location of Components

5.5.8 TYPE 791795-1 BATTERY PACK ASSEMBLY

REF DESIG PREFIX A9

| REF DESIG | DESCRIPTION | QTY. PER ASSY. | MANUFACTURER'S PART NO. | MFR. CODE | RECM. VENDOR |
|-----------|---------------|----------------|-------------------------|-----------|--------------|
| A1 | D-Cell Insert | 1 | 791792-1 | 14632 | |

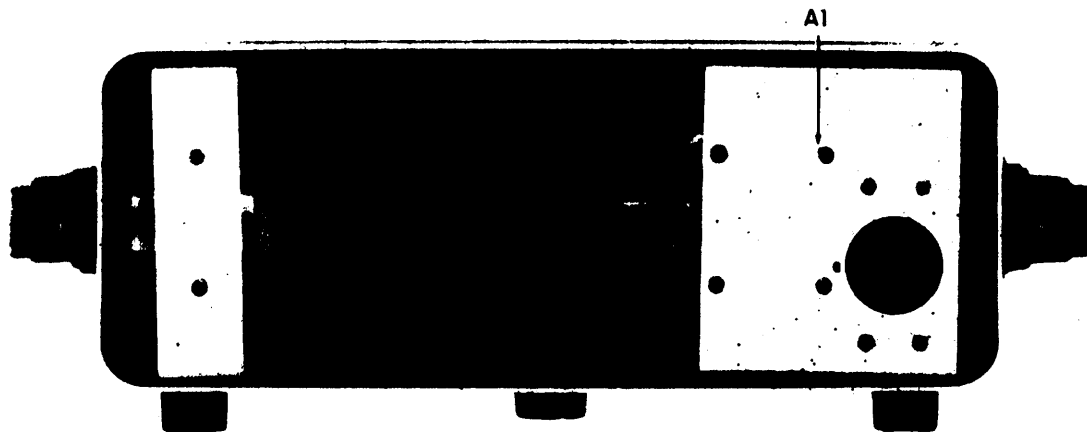


Figure 5-26. Type 791795-1 Battery Pack Assembly (A9), Location of Components

5.5.8.1 Type 791792-1 D-Cell Insert Assembly

REF DESIG PREFIX A9A1

| REF DESIG | DESCRIPTION | QTY. PER ASSY. | MANUFACTURER'S PART NO. | MFR. CODE | RECM. VENDOR |
|---------------------|---|----------------------|----------------------------|--------------|-----------------|
| BT1 | Battery | 10 | E95 | 83740 | |
| BT2 Thru BT10 | Same as BT1 | | | | |
| F1 | Fuse, Cartridge: 3/4 Amplifier, 3AG, Slow-Blow | 1 | MDL 3/4 | 71400 | |
| J1 | Connector, Receptacle: Multipin | 1 | M4SLRN | 81312 | |
| P1 | Connector, Plug: Multipin | 1 | 103-1 | 16237 | |
| XF1 | Fuseholder | 1 | 357001 | 75915 | |
| | NOTE: BT1-BT10 Shown On Schematic But Not Supplied With Unit. | | | | |

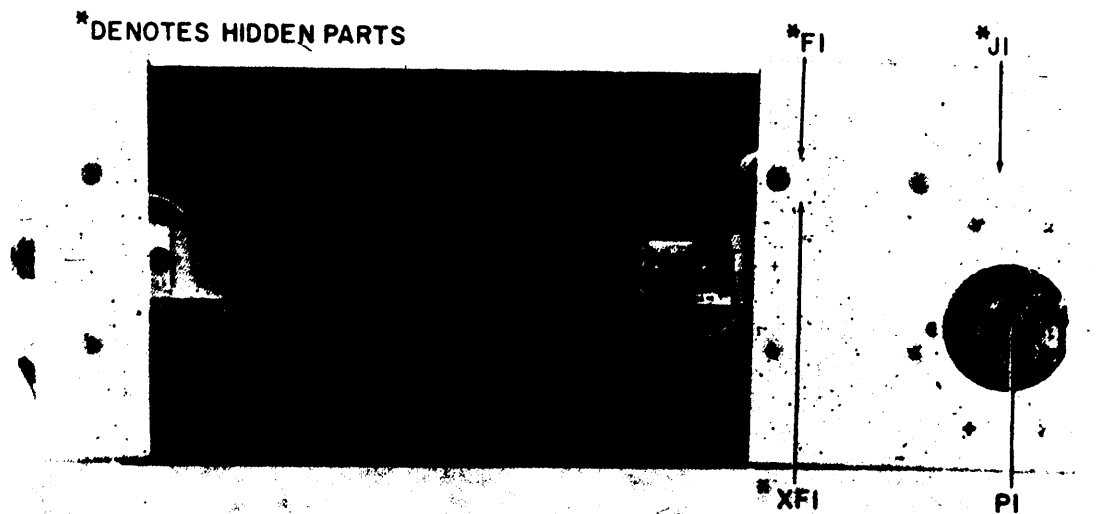


Figure 5-27. Type 791792-1 D-Cell Insert Assembly (A9A1), Location of Components

FIGURE 5-28

TM 11-5895-1227-14-1

5.5.9 TYPE 791809-1 FRONT PANEL PROTECTIVE COVER W/SPEAKER REF DESIG PREFIX A10

| REF DESIG | DESCRIPTION | QTY. PER ASSY. | MANUFACTURER'S PART NO. | MFR. CODE | RECM. VENDOR |
|--------------|---------------------------|----------------------|----------------------------|--------------|-----------------|
| A1 | Audio Amplifier | 1 | 24999 | 14632 | |
| LS1 | Speaker | 1 | LAW-SM-C-620662 | 84792 | |
| P1 | Plug: Multipin | 2 | GC329 | 25350 | |
| AI1 | Connector, Plug: Multipin | 1 | U316U | 25350 | |
| AI2 | Same as P1 | | | | |

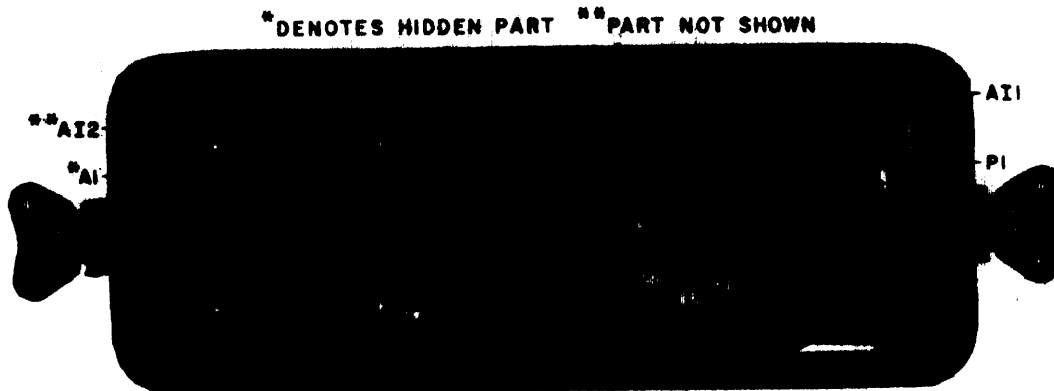


Figure 5-28. Type 791809-1 Front Panel Protective Cover W/ Speaker (A10), Location of Components

5.5.9.1 Part 24999 Audio Power Amplifier

REF DESIG PREFIX A10A1

| REF DESIG | DESCRIPTION | QTY. PER ASSY. | MANUFACTURER'S PART NO. | MFR. CODE | RECM. VENDOR |
|------------------|---|----------------------|----------------------------|--------------|-----------------|
| C1 | Capacitor, Electrolytic, Tantalum: 100 μ F, 20%, 20 V | 6 | 196D107X0020TE4 | 56289 | |
| C2 Thru C6 | Same as C1 | | | | |
| CR1 | Diode | 2 | 1N4446 | 80131 | 93332 |
| CR2 | Same as CR1 | | | | |
| CR3 | Diode | 1 | 1N4003 | 80131 | 04713 |
| E1 | Terminal, Turret | | 160-2034-02-01 | 71279 | |
| E2 Thru E5 | Same as E1 | | | | |
| Q1 | Transistor | 1 | 2N3440 | 80131 | 04713 |
| Q2 | Transistor | 1 | 2N5415 | 80131 | 04713 |
| R1 | Resistor, Fixed, Film: 2.21 k Ω , 1%, 1/4 W | 2 | RN60D2211F | 81349 | 75042 |
| R2 | Resistor, Fixed, Composition: 20 Ω , 5%, 1/4 W | 1 | RCR07G200JS | 81349 | 01121 |
| R3 | Same as R1 | | | | |
| R4 | Resistor, Fixed, Film: 100 Ω , 1%, 1/4 W | 1 | RN60D1000F | 81349 | |
| R5 | Resistor, Fixed, W-W: 2.0 Ω , 5%, 2 W | 2 | BWH20HMJ | 75042 | |
| R6 | Same as R5 | | | | |
| RA1 | Heatsink | 2 | 207CB | 05820 | |
| RA2 | Same as RA1 | | | | |

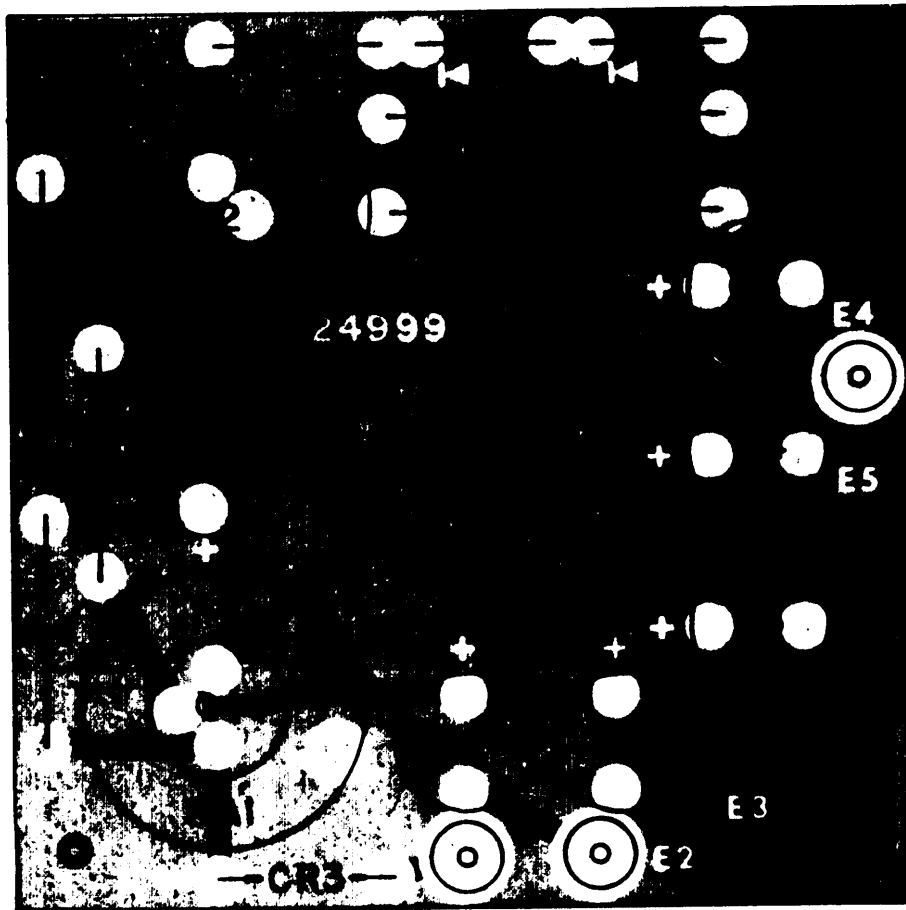


Figure 5-29. Part 24999 Audio Power Amplifier (A10A1),
Location of Components

SECTION VI
SCHEMATIC DIAGRAMS

Courtesy of <http://BlackRadios.terryo.org>

SUPPLEMENT INSTRUCTION MANUAL
FOR THE
WJ-8640/BC BATTERY CHARGER

WATKINS-JOHNSON COMPANY
700 QUINCE ORCHARD ROAD
GAITHERSBURG, MARYLAND 20878

2nd Printing 1/79
8/82

WARNING

This equipment employs voltages which are dangerous and maybe fatal if contacted. Extreme caution should be exercised in working with the equipment when it is removed from its protective case.

CAUTION

Before applying power to the unit, verify that the voltage source selector slide switch (on rear panel) is corresponding to the line voltage being used. Damage to the unit will result if this switch is set incorrectly.

PROPRIETARY STATEMENT

This document and subject matter disclosed herein are proprietary items to which Watkins-Johnson Company retains the exclusive right of dissemination, reproduction, manufacture and sale.

This document is provided to the individual or using organization for their use alone in the direct support of the associated equipment unless permission or further disclosure is expressly granted in writing.

7.1 GENERAL CHARACTERISTICS

7.1.1 The WJ-8640/BC Battery Charger is designed to be used in conjunction with the Type WJ-8640 series of Portable Receivers and the Type WJ-9180 series of Signal Monitors. The Battery Charger unit is designed to convert 115/230 vac, 50-400 Hz power source into a 14.25 vdc, 620 ma output voltage. This 14.25 v dc voltage is used to recharge a D-Cell type insert which is used as a power source in the above mentioned equipment. A voltage selector slide switch which is located on the units rear panel allows the operator to conveniently match the switch's position to the level of ac input voltage being used.

7.1.2 The D-Cell Inserts that supply the portable equipment power consists of 10 rechargeable D-Cell batteries. These batteries are housed in cardboard tubes which are secured to the main chassis by six battery retaining clips. These clips prevent movement of the batteries during shipping and "in-field" use.

7.1.3 All operator controls are located in a recessed waterproof/dustproof enclosure which is located on the units bottom panel. A protective cover may be attached over this recess while the unit is being transported or being used away from the ac power source. When the recess cover is in place, the ac power cord is conveniently stored inside the enclosure. Located in the recessed enclosure are all the controls necessary for proper operation. The controls included are a toggle type ON/OFF switch (S1), voltage level source selector (slide type, S2), fuses F1 and F2, power "ON" switch indicator (DS1), and a three foot long ac power cord that is permanently affixed to the unit.

7.1.4 The WJ-8640/BC Battery Charger is housed in a cabinet that is 5 inches deep, 4 inches high and 10.5 inches wide. Its design allows it to be attached to the associated unit, replacing its battery pack, by two side mounted Wing Turn catches. Mounted in the unit is one P. C. board and its associated hardware.

7.2 EQUIPMENT SUPPLIED

7.2.1 The equipment supplied consists of the Type WJ-8640/BC Battery Charger and a Type 791792-2 D-Cell Insert.

7.3 EQUIPMENT REQUIRED BUT NOT SUPPLIED

7.3.1 The proper use of the Battery Charger unit requires ac power that supplies a source of 115/230 vac, 50-400 Hz, and one of the WJ-8640 series Receivers or WJ-9180 series Signal Monitors.

7.4 OPERATION

7.4.1 The only operation that is required for the Battery Charger to operate properly is for the ON/OFF switch, S1, to be activated. Upon applying power to the unit, the light that is located directly above the switch should illuminate (DS1). If this fails to occur verify that the ac source being used is on.

NOTE

Caution should be exercised before energizing the unit. Verify that the line voltage switch, S2, corresponds to the supply voltage being used.

7.5 CIRCUIT DESCRIPTION

7.5.1 The WJ-8640/BC Battery Charger converts an ac source, that enters at P1, into a regulated dc voltage. This regulated dc source then enters the D-Cell Insert (A2) at input jack A2J1. In the following paragraphs is a description of the circuits operation.

7.5.2 The ac input supply voltage is stepped down across transformer T1 from either a 115 vac or 230 vat, 50-400 Hz, to 24 vdc. Diodes CR1 through CR4 make-up a full-wave bridge rectifier which rectifies the 24 volts across A1E1 & A1E3. The voltage is filtered by capacitor C1. The circuits supplied after rectification consists of a closed-loop voltage sampler circuit and the supply voltage for power transistor Q 1 (main chassis).

7.5.2.1 The voltage sampling circuit is centered around AIU1. The 24 volts is regulated by the zener reference diode A1VR2, at 6.8 V. Resistors R5, R9 and capacitor C3 form a filtering network which reduces the noise created by the Zeners clamping action. The resultant 6.8 v serves as a reference level for comparator AIU1. This 6.8 volt reference level enters inverting input, U1 pin 2. Until current limiting is started, the I. C. provides a gain of 50 (at D. C.). The comparators output, U1 pin 6, amplified by current driver A1Q1, is coupled to Q1's base.

7.5.2.2 The second path for the rectified input voltage is through A1E4 to the emitter of Q1. Resistor R1 is for current limiting and Q1 is a power transistor. Initially a 24 vdc voltage is present at the emitter of Q1 which provides O to 620 ma at 14.25 v until current limiting is achieved at the collector of Q 1. This current is taken from the collector through CR5, E7, and P2 to the D-Cell Insert. A portion (output load dependent) of this output voltage is tapped off at CR5-R4 junction where a voltage sampling circuit consists of resistors R4, R? and potentiometer R6. The amount of voltage that is present at U 1 pin 3 helps determine the conduction rate of Q1 (main chassis). when the sampling voltage is lower than the reference voltage, a decrease in U1's output will increase the conduction of Q1. Q1's conduction depends on the biasing of its base-emitter junction along with the load placed on its collector by the D-Cell Insert's level of charge. This rate of conduction will vary accordingly until a voltage of 6.8 volts or greater is placed across Q1's base-emitter junction. This level of voltage will forward bias Zener diode VR1 (6. 8 reference) thereby limiting the amount of current developed through R1 to 620 ma (maximum). Until this limiting action occurs, Q1 acts as a voltage source whereas once the 620 ma limit is reached its characteristics are that of a current source.

7.5.2.3 The output of the Regulator Board (A1) is connected to input connector J1 of the D-Cell Insert (A2). The D-Cell Insert, Type 791792-2, contains 10 rechargeable NiCad

batteries (≈1.2 volts/cell). As the load at output P2 is reduced, indicating a higher battery voltage level, the output current is reduced and the output voltage approaches 14.25 volts (maximum). See Figure 7-1 for a characteristic curve of the charging rate for NiCad type batteries (D-Cell Insert). Potentiometer R6 is adjusted for an output voltage level at P2 of 14.25 vdc. A fullcharge on a D-Cell Insert requires approx. 14-16 hrs.

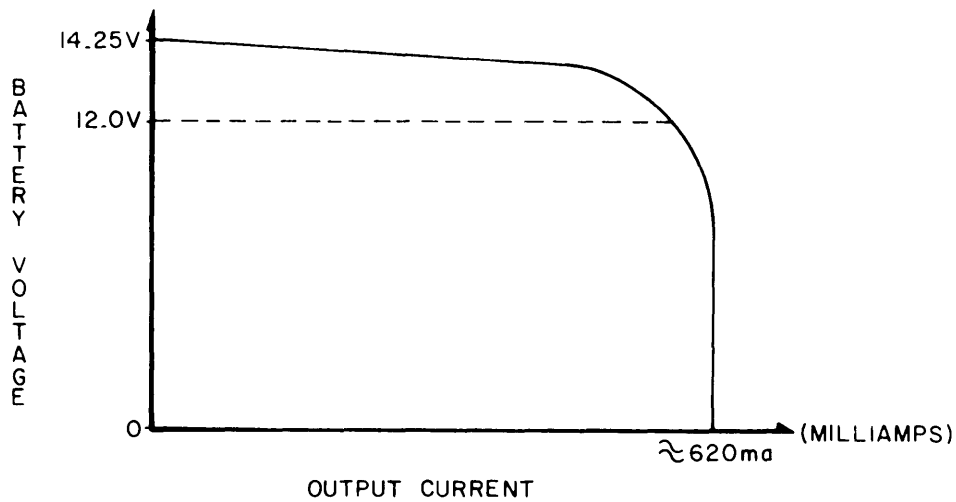


Figure 7-1. Characteristic Curve for charging of D-Cell NiCad Battery Insert.

7.6 TROUBLESHOOTING

7.6.1 Prior to performing corrective maintenance on the unit, the section which discusses the circuit operation should be reviewed to determine why the failure affected the equipment in the manner it did. This review is necessary to make certain that the problem discovered is actually the cause and not just the result of the malfunction.

7.7 LIST OF MANUFACTURERS

| <u>Mfr. Code</u> | <u>Name and Address</u> | <u>Mfr. Code</u> | <u>Name and Address</u> |
|----------------------|--|----------------------|---|
| 01121 | Allen-Bradley Company 1201 South 2nd Street Milwaukee, Wisconsin 53204 | 04713 | Motorola Inc. Semiconductor Products Div. 5005 East McDowell Road Phoenix, Arizona 85008 |

| <u>Mfr. Code</u> | <u>Name and Address</u> | <u>Mfr. Code</u> | <u>Name and Address</u> |
|----------------------|---|----------------------|--|
| 07263 | Fairchild Camera and Instrument Corporation Semiconductor Division 464 Ellis Street Mount View, California 94040 | 73138 | Beckman Instruments Inc Helipot Division 2500 Harbor Boulevard Fullerton, California 92634 |
| 08717 | Sloan Company 7704 San Fernando Road Sun Valley, California 91352 | 75042 | TRW Electronic Components LRC Fixed Resistors Philadelphia Division 401 North Broad Street Philadelphia, Penn. 19108 |
| 09823 | Burgess Inc. Foot of Exchange Street Box 605 Freeport, Ill. 61032 | 75915 | Littelfuse, Incorporated 800 E. Northwest Highway Des Plaines, Ill. 60016 |
| 14632 | Watkins-Johnson Company 700 Quince Orchard Road Gaithersburg, Maryland 20878 | 80131 | Electronic Industries Assoc. 2001 Eye Street, N. W. Washington, D. C. 20006 |
| 16237 | Connector Corp. 6025 N. Keystone Avenue Chicago, Ill. 60646 | 81312 | Winchester Electronics Division Litton Industries, Incorporated Main Street & Hillside Avenue Oakville, Connecticut 06779 |
| 56289 | Sprague Electric Company Marshall Street North Adams, Mass. 01247 | 81349 | Military Specifications |
| 71279 | Cambridge Thermionic Corp. 445 Concord Avenue Cambridge, Mass. 02138 | 82389 | Switchcraft Inc. 5555 North Elston Avenue Chicago, Ill. 60630 |
| 71400 | Bussman Manufacturing Division of McGraw-Edison 2536 W. University Street St. Louis, Mo. 63107 | 91637 | Dale Electronics, Inc. P.O. Box 609 Columbus, Nebraska 68601 |
| 72136 | Electro Motive Mfr. Co. , Inc. South Park & John Streets Willimantic, Connecticut 06226 | 95146 | Alto Electronics Products, Inc. P.O. Box 1348 Lawrence, Mass. 01842 |

7.8 PARTS LIST

The parts list which follows contains all electrical parts used in the equipment which are subject to damage. When ordering replacement parts from Watkins-Johnson Company specify the type and serial number of the equipment and the reference designation and description of each part ordered. The list of manufacturers provided in paragraph 7.7 and the manufacturer's part number for components are included as a guide to the user of the equipment in the field. These parts may not necessarily agree with the parts installed in the equipment; however, the parts specified in this list will provide satisfactory operation of the equipment. Replacement parts may be obtained from any manufacturer as long as the physical and electrical parameters of the part selected agree with the original indicated part. In the case of components defined by a military or industrial specification, a vendor which can provide the necessary component is suggested as a convenience to the user.

NOTE

As improved semiconductors become available, it is the policy of Watkins-Johnson to incorporate them in proprietary products. For this reason some transistors, diodes and integrated circuits installed in the equipment may not agree with those specified in the parts list and schematic diagrams of this manual. However, the semiconductors designated in the manual may be substituted in every case with satisfactory results.

FIGURE 7-2

TM 11-5895-1227-14-1

7.9 TYPE WJ-8640/BC BATTERY CHARGER, MAIN CHASSIS

| REF DESIG | DESCRIPTION | QTY. PER ASSY. | MANUFACTURER'S PART NO. | MFR. CODE | RECM. VENDOR |
|-----------|--|----------------|-------------------------|-----------|--------------|
| A1 | Regulator Board | 1 | 24959 | 14632 | |
| A2 | D-Cell Insert Assembly | 1 | 791792-2 | 14632 | |
| C1 | Capacitor, Electrolytic, Aluminum: 1100 μ F, 40 V | 1 | 39D118G040HL4 | 56289 | |
| C2 | Capacitor, Electrolytic, Tantalum: 47 μ F, 10%, 35 V | 1 | CS13BF476K | 81349 | 56289 |
| DS1 | Lamp, Incandescent | 1 | FB44 | 08717 | |
| F1 | Fuse, Cartridge: 1/4 Amp, 3AG Slow | 1 | MDL1/4 | 71400 | |
| F2 | Fuse, Cartridge: 1/8 Amp, 3AG Slow | 1 | MDL1/8 | 71400 | |
| P2 | Connector, Plug | 1 | M4PLSH10C | 81312 | |
| Q1 | Transistor | 1 | 2N3790 | 80131 | |
| R1 | Resistor, Fixed: 10 Ω , 1%, 5 W | 1 | R45-10 OHMS/F | 91637 | |
| S1 | Switch, Toggle | 1 | MTA106D | 95146 | |
| S2 | Switch, Slide | 1 | 11A1211 | 82389 | |
| T1 | Transformer | 1 | 16627 | 14632 | |
| XDS1 | Lamp Holder | 1 | 102SA | 08717 | |
| XF1 | Fuseholder | 2 | 342004 | 75915 | |
| XF2 | Same as XF1 | | | | |

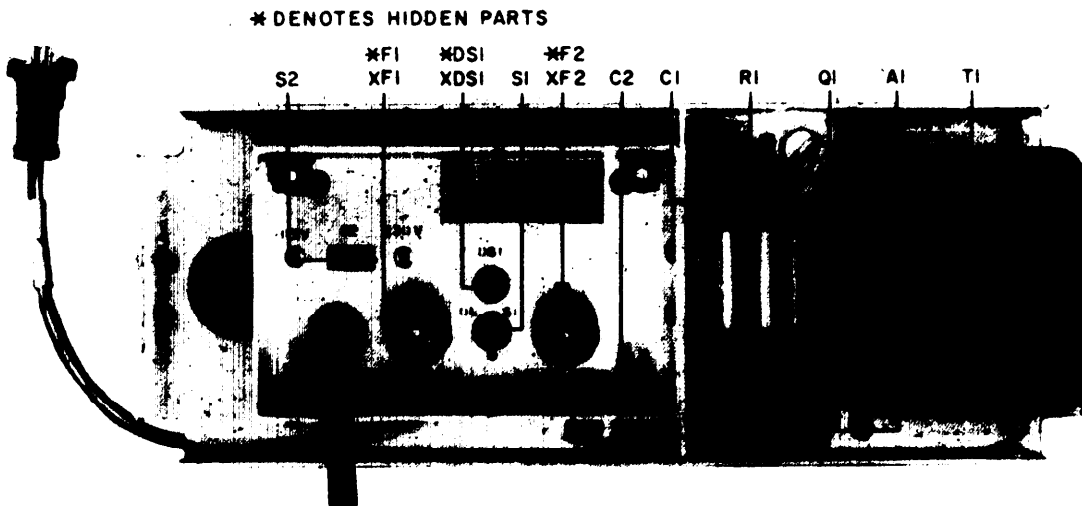


Figure 7-2. WJ-8640/BC Battery Charger, Location of Components

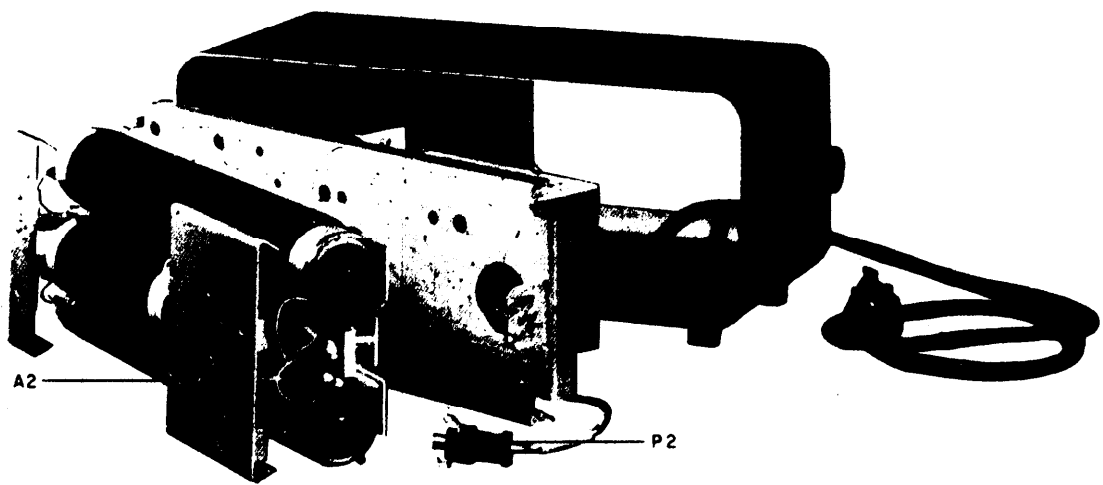


Figure 7-3. WJ-8640/BC Battery Charger,
Location of Components

7.9.1 PART 24959 REGULATOR ASSEMBLY

REF DESIG PREFIX AI

| REF DESIG | DESCRIPTION | QTY. PER ASSY. | MANUFACTURER'S PART NO. | MFR. CODE | RECM. VENDOR |
|--------------|---|----------------------|----------------------------|--------------|-----------------|
| C1 | Capacitor, Electrolytic, Tantalum: 47 μ F, 10%, 35 V | 1 | CS13BF476K | 81349 | 56289 |
| C2 | Capacitor, Mica, Dipped: 470 pF, 5%, 500 V | 1 | DM15-471J | 72136 | |
| C3 | Capacitor, Electrolytic, Tantalum: 2.2 μ F, 10%, 20 V | 1 | CS13BE225K | 81349 | 56289 |
| CR1 | Diode | 5 | 1N4003 | 80131 | 04713 |
| CR2 | Same as CR1 | | | | |
| CR3 | Same as CR1 | | | | |
| CR4 | Same as CR1 | | | | |
| CR5 | Same as CR1 | | | | |
| E1 | Terminal, Forked | 8 | 140-1941-02-01 | 71279 | |
| E2 | Same as E1 | | | | |
| E3 | Same as E1 | | | | |
| E4 | Same as E1 | | | | |
| E5 | Same as E1 | | | | |
| E6 | Same as E1 | | | | |
| E7 | Same as E1 | | | | |
| E8 | Same as E1 | | | | |
| Q1 | Transistor, High Speed | 1 | 2N2905A | 80131 | 04713 |
| R1 | Resistor, Fixed, Wire-Wound: 360 Ω , 5%, 2 W | 1 | BWH(360 OHM J) | 75042 | |
| R2 | Resistor, Fixed, Composition: 1.0 k Ω , 5%, 1/4 W | 3 | RCR07G102JS | 81349 | 01121 |
| R3 | Resistor, Fixed, Composition: 100 k Ω , 5%, 1/4 W | 1 | RCR07G104JS | 81349 | 01121 |
| R4 | Resistor, Fixed, Composition: 10 k Ω , 5%, 1/4 W | 1 | RCR07G103JS | 81349 | 01121 |
| R5 | Same as R2 | | | | |
| R6 | Resistor, Trim, Film: 5 k Ω , 10%, 1/2 W | 1 | 62PR5K | 73138 | |
| R7 | Resistor, Fixed, Composition: 12 k Ω , 5%, 1/4 W | 1 | RCR07G123JS | 81349 | 01121 |
| R8 | Resistor, Fixed, Composition: 3.3 k Ω , 5%, 1/4 W | 1 | RCR07G332JS | 81349 | 01121 |
| R9 | Same as R2 | | | | |
| U1 | Integrated Circuit | 1 | 741HC | 07263 | |
| VR1 | Diode, Zener: 6.8 V | 2 | 1N754A | 80131 | 04713 |
| VR2 | Same as VR1 | | | | |

COMPONENT VIEW

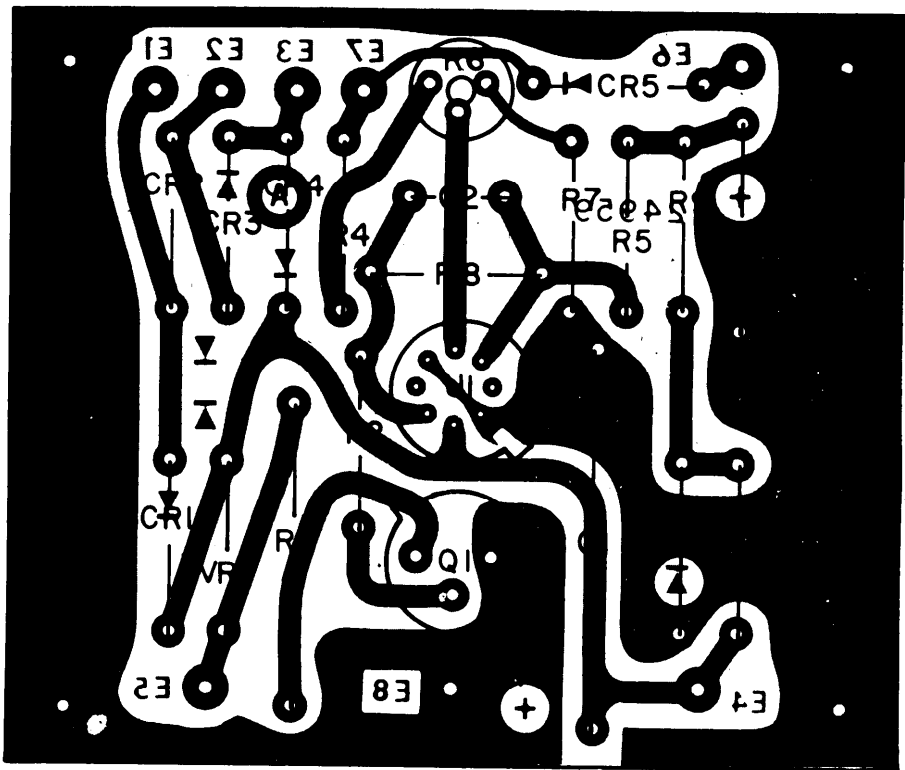


Figure 7-4. Part 24959 Regulator Assembly (A1),
Location of Components

7.9.2 TYPE 791792-2 D-CELL INSERT ASSEMBLY

REF DESIG PREFIX A2

| REF DESIG | DESCRIPTION | QTY. PER ASSY. | MANUFACTURER'S PART NO. | MFR. CODE | RECM. VENDOR |
|--------------|------------------------------------|----------------------|----------------------------|--------------|-----------------|
| BT1 | Battery | 10 | CD10 | 09823 | |
| BT2 | Same as BT1 | | | | |
| BT3 | Same as BT1 | | | | |
| BT4 | Same as BT1 | | | | |
| BT5 | Same as BT1 | | | | |
| BT6 | Same as BT1 | | | | |
| BT7 | Same as BT1 | | | | |
| BT8 | Same as BT1 | | | | |
| BT9 | Same as BT1 | | | | |
| BT10 | Same as BT1 | | | | |
| F1 | Fuse, Cartridge: 3/4 Amp, 3AG Slow | 1 | MDL3/4 | 71400 | |
| J1 | Connector, Receptacle | 1 | 18625-1 | 14632 | |
| P1 | Connector, Plug, Multipin | 1 | 103-1 | 16237 | |
| XF1 | Fuseholder | 1 | 357001 | 75915 | |

APPENDIX A

REFERENCES

A-1. SCOPE

This appendix lists forms and publications that are referenced in this manual or that contain information applicable to the operation and maintenance of Receiver, R-2200/GRR-8(V).

A-2. FORMS

| | |
|----------------|---|
| DA Form 2028 | Recommended Changes to Publications and Blank Forms |
| DA Form 2028-2 | Recommended Changes to Equipment Technical Manuals |
| DA Form 2062 | Hand Receipts |
| DA Form 2404 | Equipment Inspection and Maintenance Worksheet |
| DA Form 2407 | Maintenance Request |
| SF 361 | Discrepancy in Shipment Report |
| SF 364 | Report of Packaging and Handling Deficiency |
| SF 368 | Quality Deficiency Report |

A-3. DEPARTMENT OF THE ARMY PAMPHLETS

| | |
|----------------|---|
| DA Pam 25-30 | Consolidated Index of Army Publications and Blank Forms |
| DA Pam 738-750 | The Army Maintenance Management System (TAMMS) |

A-4. FIELD MANUALS

| | |
|-----------|---------------------------|
| FM 21-11 | First Aid for Soldiers |
| FM 30-476 | Radio Direction Finding |
| FM 31-70 | Basic Cold Weather Manual |

A-5. SUPPLY BULLETINS

| | |
|----------|---|
| SB 11-6 | FSC Class 6135: Dry Battery Supply Date |
| SB 11-30 | FSC Class 6135: Dry Battery Management Data |

TM 11-5895-1227-14-1

REFERENCES — Continued

A-6. TECHNICAL BULLETINS

- TB 43-0129 Safety Measures to be Observed When Installing and Using Whip Antennas, Field Type Masts, Towers, and Antennas, and Metal Poles That Are Used With Communications, Radios, and Direction Finder Equipment
- TB 43-0118 Field Instructions For Painting and Preserving Communications-Electronics Equipment

A-7. TECHNICAL MANUALS

- TM 11-5825-278-12-1 Operator's and organizational Maintenance Manual, Radio Direction Finder Set AN/PRD-11 (NSN 5825-01-188-3435)
- TM 11-5825-278-12-1 Operator's and organizational Maintenance Manual, Radio Direction Finder Set AN/PRD-11 (NSN 5825-01-188-3435)
- TM 11-5825-278-23P Organizational and Direct Support Maintenance Repair Parts and Special Tools List for Radio Receiver Direction Finder Set AN/PRD-11 (NSN 5825-01-188-3435)
- TM 11-5895 -1227-14-1 Operator, Organizational, Direct Support and General Support Maintenance, Receiver R-2200/GRR-8(V) (NSN 5895-01-060-6492)
- TM 11-5895 -1227-14-1-1 Operator, Organizational, Direct Support and General Support Maintenance, Tuner TN-586/GRR-8(V) (NSN 5895-01-075-6394)
- TM 11-5895 -1227-14-1-2 Operator, Organizational, Direct Support and General Support Maintenance, Tuner TN-584/GRR-8(V) (NSN 5895-01-075-6391)
- TM 11-5895 -1227-14-1-3 Operator, Organizational, Direct Support and General Support Maintenance, Tuner TN-585/GRR-8(V) (NSN 5895-01-073-1582)
- TM 11-5895 -127-14-2 Operator, Organizational, Direct Support and General Support Maintenance, Processor Display Control C-11495/PRQ-11 (NSN 5820-01-160-4411)
- TM 11-5895 -1227-14-3 Operator, Organizational, Direct Support and General Support Maintenance, Panoramic Indicator IP-1355/PRQ-8(V) (NSN 5820-01-073-1604)
- TM 11-5895 -1227-14-4 Operator, Organizational, Direct Support and General Support Maintenance, Direction Finder Antenna AS-3732/PRD-11 (NSN 5820-01-165-4578) and Direction Finder Antenna AS-3733/PRD-11 (NSN 5820-01-200-0177)

APPENDIX B

MAINTENANCE ALLOCATION CHART

Section I. INTRODUCTION**B-1. GENERAL**

This appendix provides a summary of the maintenance operations for the Radio Receiver, AN/GRR-8(V). It authorizes categories of maintenance on repairable items and components and the tools and equipment required to perform each function. This appendix may be used as an aid in planning maintenance operations.

B-2. MAINTENANCE FUNCTION

Maintenance functions will be limited to and defined as follows:

a. Inspect. To determine the serviceability of an item by comparing its physical, mechanical and/or electrical characteristics with established standards through examination.

b. Test. To verify serviceability and to detect incipient failure by measuring the mechanical or electrical characteristics of an item and comparing those characteristics with prescribed standards.

c. Service. Operations required periodically to keep an item in proper operating condition, i.e., to clean (decontaminate), to preserve, to drain, to paint, or to replenish fuel, lubricants, hydraulic fluids, or compressed air supplies

d. Adjust. To maintain, within prescribed limits, by bringing into proper or exact position, or by setting the operating characteristics to the specified parameters

e. Align. To adjust specified variable elements of an item to bring about optimum or desired performance.

f. Calibrate. To determine and cause corrections to be made or to be adjusted on instruments or test measuring and diagnostic equipments used in precision measurement. Consists of comparisons of two instruments, one of which is a certified standard of known accuracy, to detect and adjust any discrepancy in the accuracy of the instrument being compared.

g. Install. The act of emplacing, seating, or fixing into position an item, part, module (component or assembly) for an unserviceable counterpart.

h. Replace. The act of substituting a serviceable like type part, subassembly, or module (component or assembly) for an unserviceable counterpart.

B-2. MAINTENANCE FUNCTIONS - Continued

i. Repair. The application of maintenance services (inspect, test, service, adjust, align, calibrate, replace) or other maintenance actions (welding, grinding, riveting, straightening, facing, remachining, or resurfacing) to restore serviceability to an item by correcting specific damage, fault, malfunction, or failure in a part, subassembly, module (component or assembly), end item, or system.

j. Overhaul. That maintenance effort (service/action) necessary to restore an item to a completely serviceable/operational condition as prescribed by maintenance standards (i.e. DMWR) in appropriate technical publications. Overhaul is normally the highest degree of maintenance performed by the Army. Overhaul does not normally return an item to like new condition.

k. Rebuild. Consists of those services/actions necessary for the restoration of unserviceable equipment to a like new condition in accordance with original manufacturing standards. Rebuild is the highest degree of materiel maintenance applied to Army equipment. The rebuild operation includes the act of returning to zero those age measurements (hours, miles, etc.) considered in classifying Army equipments/components.

B-3. COLUMN ENTRIES

a. Column 1, Group Number. Column 1 lists group numbers, the purpose of which is to identify components, assemblies, subassemblies, and modules with the next higher assembly.

b. Column 2, Component/Assembly. Column 2 contains the noun names of components, assemblies, subassemblies, and modules for which maintenance is authorized.

c. Column 3, Maintenance Function. Column 3 lists the functions to be performed on the item listed in column 2. When items are listed without maintenance functions, it is solely for purpose of having the group numbers in the MAC and RPSTL coincide.

d. Column 4, Maintenance Category. Column 4 specifies, by the listing of a work time figure in the appropriate subcolumn, the lowest level of maintenance authorized to perform the function listed in column 3. This figure represents the active time required to perform that maintenance function at the indicated category of maintenance. If the number or complexity of the tasks within the listed maintenance function vary at different maintenance categories, appropriate work time figures will be shown for each category. The number of task hours specified by the work time figure represents the average time required to restore an item to serviceable condition under typical field operating conditions. This time includes preparation time, troubleshooting time, and quality assurance/quality control time in addition to the time required to perform the specific tasks identified for the maintenance functions authorized in the maintenance allocation chart. Subcolumns of column 4 are as follows:

- c Operator or crew
- o Organizational Maintenance
- F Direct Support Maintenance
- H General Support Maintenance
- D Depot Maintenance

B-3. COLUMN ENTRIES-Continued

e. Column 5, Tools and Equipment. Column 5 specifies by code, those common tools sets (not individual tools) and special tools, test, and support equipment required to perform the designated function.

f. Column 6, Remarks. Column 6 contains an alphabetical code which leads to the remark in—section IV, Remarks, which is pertinent to the item opposite the particular code.

B-4. TOOL AND TEST EQUIPMENT REQUIREMENTS (Section III)

a. Tool or Test Equipment Reference Code. The numbers in this column coincide with the numbers used in the tools and equipment column in the MAC. The numbers indicate the applicable tool or test equipment for the maintenance function.

b. Maintenance Category. The code in this column indicate the maintenance category allocated the tool or test equipment.

c. Nomenclature. This column lists the noun name and nomenclature of the tools and test equip—merit required to perform the maintenance functions.

d. National/NATO Stock Number. This column lists the National/NATO stock number of the specific tool or test equipment.

e. Tool Number. This column lists the manufacturers part number of the tool followed by the Federal Supply Code for manufacturers (5 digit) in parentheses

B-5. REMARKS

a. Reference Code. This code refers to the appropriate item in section 11, column 6.

b. Remarks. This column provides the required explanatory information necessary to clarify items appearing in section II.

Section II. MAINTENANCE ALLOCATION CHART -Continued

| (1) Group Number | (2) Component/ Assembly | (3) Maintenance Function | (4) Maintenance Category | | | | | (5) Tools and Equipment | (6) Remarks | |
|------------------------|---|--------------------------------|--------------------------------|---|-----|---|-----|-------------------------------|----------------|----|
| | | | C | O | F | H | D | | | |
| 01 | VHF Portable Receiver | Inspect | 0.1 | | | | | | | |
| | | Inspect | | | | | | | | |
| | | Inspect | | | | | | | | |
| | | Replace | | | 0.2 | | | — | — | |
| | | Repair | | | 0.2 | | | | 1 | |
| | | Repair | | | 0.4 | | | | 6 | B, |
| | | Repair | | | | | | 1.0 | 6 | O, |
| | | Test | | | | | | | 2-14 | |
| 0101 | Antenna Switch Assembly (A1) | Replace | | | 0.2 | | | 6 | | |
| | | Repair | | | | | 0.5 | 6 | O | |
| 0102 | Tuner (A2) TN-586/GRR-8(V) TN-584/GRR-8(V) TN-585/GRR-8(V) | Replace | | | 0.2 | | | 6 | P | |
| | | Test | | | | | 2.0 | 2-5,8-12 | O | |
| | | Repair | | | | | 1.0 | 6 | O | |
| 0103 | Counter Assy (A3) | Repair | | | 0.5 | | | 6 | F | |
| | | Repair | | | | | 1.5 | 6 | O | |
| | | Test | | | 0.3 | | | 2-3,8-9, 12-13 | | |
| 010301 | Counter Board (A3A1) | Replace | | | 0.3 | | | 6 | | |
| | | Repair | | | 0.5 | | | 6 | | |
| | | Repair | | | | | 1.0 | 6 | O | |
| | | Test | | | 0.3 | | | 2-3,8-9, 12-13 | | |
| 01030101 | Display Board (A3A1A1) | Replace | | | 0.5 | | | 6 | | |
| | | Repair | | | | | 1.0 | 6 | O | |
| 010302 | Wide Band Amp (A3A2) | Replace | | | 0.3 | | | 6 | P | |
| | | Repair | | | | | 1.0 | 6 | O | |
| 0104 | IF Demodulator (A4) | Repair | | | 0.5 | | | 6 | C | |
| | | Repair | | | | | 2.0 | 6 | O | |
| | | Test | | | 0.3 | | | 4-5,8-11 | | |
| | | Test | | | | | 3.0 | 4-5,8-11 | O | |
| 010401 | IF Filters and Diode Switches (A4A4) | Replace | | | 0.3 | | | 6 | | |
| | | Repair | | | | | 1.0 | 6 | O | |

Section II. MAINTENANCE ALLOCATION CHART-Continued

| (1) Group Number | (2) Component/ Assembly | (3) Maintenance Function | (4) Maintenance Category | | | | | (5) Tools and Equipment | (6) Remarks |
|------------------------|--|---|--------------------------------|-----|-------------------|---|---|-----------------------------------|----------------|
| | | | C | O | F | H | D | | |
| 010402 | AM Detector Buffer (A4A6) | Replace Repair | | | 0.3 | | | 6 6 | O |
| 010403 | Product Detector (A4A7) | Replace Repair Test | | | 0.3 | | | 6 6 2-5,8-13 | O O |
| 010404 | LSB/USB Filters (A4A9) | Replace Repair | | | 0.3 | | | 6 6 | O |
| 0105 | AGC Squelch (A5) | Replace Repair Test | | | 0.3 | | | 6 6,8-11 2-3,8-11 | O O |
| 0106 | DC/DC Converter (A6) | Replace Repair Repair Test Test | | | 0.4 0.4 0.3 | | | 6 6 6 2-3,8-9 2-3,8-9 | P O O |
| 0107 | FM Discriminator (A7) | Replace Repair Test | | | 0.3 | | | 6 6 2-5,8-11 | O O |
| 0108 | Audio/Record Amplifier (A8) | Replace Repair | | | 0.3 | | | 6 6 | O |
| 0109 | D-Cell Insert (A9) | Replace Repair Repair Test | | 0.2 | 0.3 0.3 | | | 1 6 6 2-3 | D O |
| 0110 | Front Panel Protective Covers with Speakers (A10) | Replace Repair Test | | 0.2 | 0.3 0.3 | | | 6 6 — | P E |

Section III. TOOL AND TEST EQUIPMENT REQUIREMENTS

| (1) Reference Code | (2) Maintenance Category | (3) Nomenclature | (4) National Stock Number | (5) Tool Number |
|--------------------------|--------------------------------|---|---------------------------------|-----------------------|
| 1 | O | Tool Kit, Electronic Equipment, TK-100/G | 5180-00-605-0079 | |
| 2 | O,F,D | Multimeter, Digital, AN/PSM-45 | 6625-01-134-2512 | |
| 3 | O,F,D | Test Lead Set, Simpson Catalog No. 00577 | N/A | |
| 4 | O,F,D | Voltmeter, RF, Boonton 92C | 6625-01-116-9500 | |
| 5 | O,F,D | High Frequency Probe, Boonton 91-21F | N/A | |
| 6 | F,D | Tool Kit, Electronic Equipment, TK-105/G | 5180-00-510-8177 | |
| 7 | F | High Voltage Probe, 5 KV, Simpson Cat. No. 00053 | N/A | |
| 8 | F,D | Power Supply, PP-6547/U | 6625-01-823-5359 | |
| 9 | F | Power Supply Leads, *Local Manufacturer | N/A | |
| 10 | F,L | Generator, Signal, SG-1112(V)I/U, w/options 001,002,003 (2 required) | 6625-00-500-6525 | |
| 11 | F,D | Cable, 50 ohms, 4 ft., BNC-BNC, HP-1053A (9 required) | 5995-00-070-8747 | |
| 12 | F,D | Oscilloscope, AN/USM-281C | 6625-00-106-9622 | |
| 13 | F,D | Voltage Probe, 10X, TEK P6006 | 6625-00-524-0572 | |

*Power Supply Leads, (+24 VDC at less than 1 amp) Banana Plugs-to a U-316/U, 14 pin plug with power (Red) Lead to pin A (Ground), Red Lead to pin E. The ground wire (BLACK) to pin A

Section III. TOOL AND TEST EQUIPMENT Requirements -Continued

| (1) Reference Code | (2) Maintenance Category | (3) Nomenclature | (4) National Stock Number | (5) Tool Number |
|--------------------------|--------------------------------|--|---------------------------------|-----------------------|
| 14 | F,D | Counter, Frequency TD-1225A(V)1/U | 6625-00-498-8946 | |
| 15 | D | Power Supply Test Leads, HP-11002A | 6625-00-079-1426 | |
| 16 | D | Analyzer, Spectrum, IP-1216/GR with PL-1388/U, PL-1406/U | 6625-00-424-4370 | |
| 17 | D | Generator, Sweep, AN/USM-308(V)1 | TBD | |
| 18 | D | Step Attenuator, HP-3550 TBD | | |

1

Section IV. REMARKS

| Reference Code | Remarks |
|----------------|--|
| B | <p>Receiver Repair is accomplished by removal and replacement of selected modules and circuit cards, intraconnecting cables, and chassis mounted piece parts.</p> |
| C | <p>IF Demodulator (Receiver) Repair is accomplished by removal and replacement of throwaways, 21.4 to 10 MHz Converter (A4A1), Gain BW Comp. Amp. (A4A3), 10 MHz Amp. (A4A5) and 10 MHz Amp. (A4A8).</p> |
| D | <p>Battery Pack (Receiver, DF and Signal Monitor) Repair is accomplished by removal and replacement of throwaway batteries and fuses, and the battery pack power plug (A9A1 P1-RCVR, A6P1-DF, or A4P1-Signal Monitor).</p> |
| E | <p>Front Panel Protective Cover with Speaker (A10) Repair is accomplished by removal and replacement of the throwaway audio power amplifier assembly (A10A1), LSI component (speaker) and multipin plug (A10P1).</p> |
| F | <p>Counter Assembly (Receiver) Repair is accomplished by the removal and replacement of Counter Board (A3A1) and the Display Board (A3A1A1).</p> |
| O | <p>Depot Tools and Equipment listed are an engineering estimate of the minimum requirement.</p> |
| P | <p>Replacement of assemblies includes piece parts and subassemblies mounted thereon.</p> |

APPENDIX C

BASIC ISSUE ITEMS

Section I. INTRODUCTION

C-1. SCOPE

This appendix lists the basic issue items for the receiver to help you inventory items required for safe and efficient operation. There are no components of end items.

C-2. GENERAL

The Basic Issue Item (BII) has the minimum essential items required to replace the receiver in operation, to operate it and to perform emergency repairs. Although shipped separately packaged, BII must be with the equipment during operation and whenever it is transferred between property accounts. This manual is your authority to request/requisition BII based on Table of Organization and Equipment/Modified Table of Organization and Equipment (TOE/MTOE) authorization of the end item.

C-3. EXPLANATION OF COLUMNS

The following provides an explanation of columns found *in* the tabular listings:

a. Column 1, National Stock Number. This column indicates the national stock number assigned to the item and will be used for requisitioning purposes

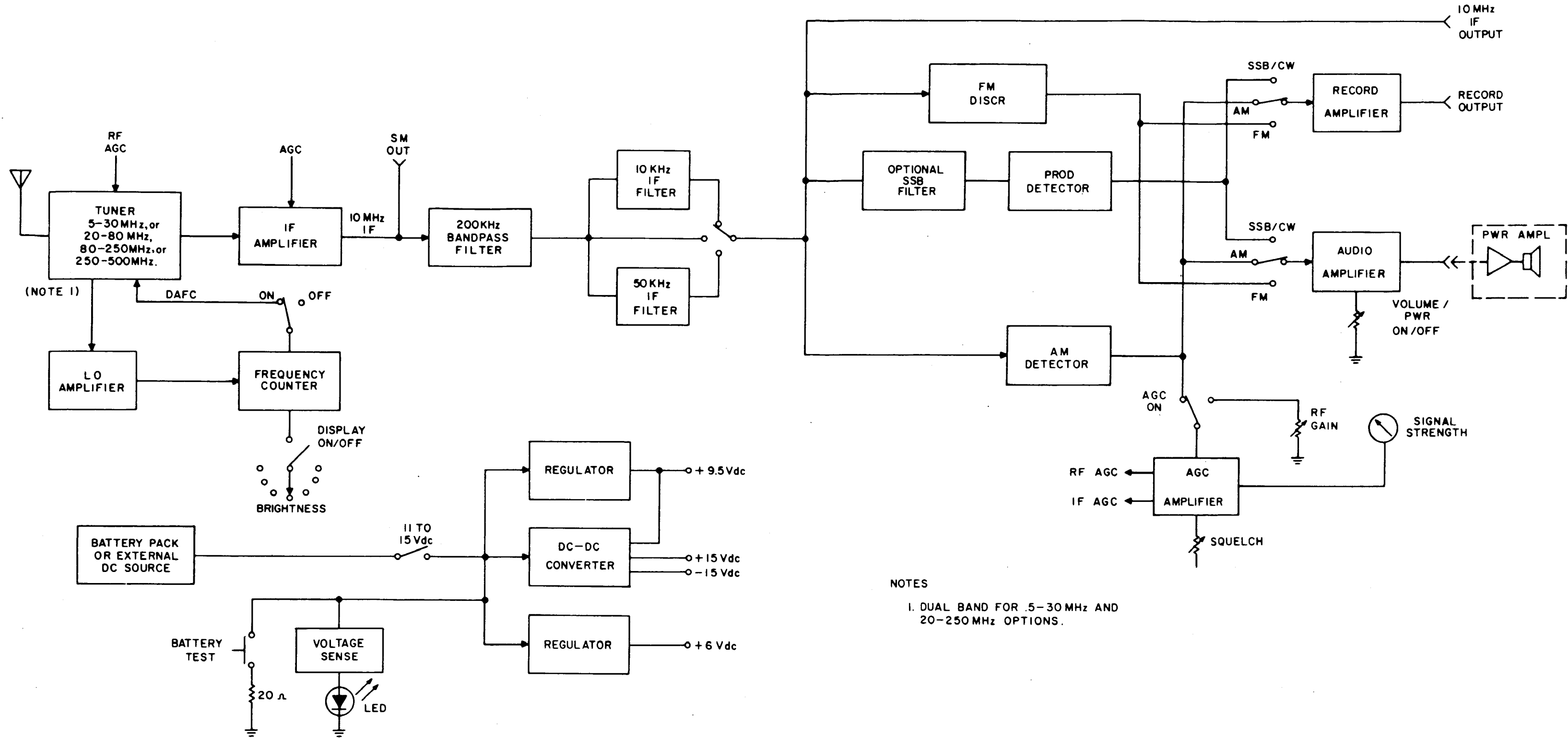
b. Column 2, Description, FSCM and Part Number. This column indicates the federal item name and, when applicable, a brief description to identify and locate the item. The last line for each item indicates the FSCM (in parentheses) followed by the part number.

c. Column 3, Unit of Measure. This column indicates the measure used in performing the actual operation/maintenance function. This measurement is expressed by a two character alphabetical abbreviation.

d. Column 4, Quantity Required. This column indicates the quantity of the item authorized to be used with/on the equipment.

Section II. BASIC ISSUE ITEMS

| (1) National Stock Number | Description | (2) FSCM | Part Number | (3) Unit of Measure | (4) Quantity Required |
|---------------------------------|---|-------------|----------------|---------------------------|-----------------------------|
| 5895-01-060-6492 | Receiver, AN/GRR-8(V) | 80058 | WJ-8640-1 | Ea. | 1 |
| 5895-01-075-3694 | Tuner, RF, TN-586/GRR-8(V) | 80058 | WJ-9120 | Ea. | 1 |
| 5895-01-075-6391 | Tuner, RF TN-584/GRR-8(V) | 80058 | WJ-9121 | Ea. | 1 |
| 5895-01-073-1582 | Tuner, RF TN-585/GRR-8(V) | 80058 | WJ-9124 | Ea. | 1 |
| 5820-00-889-3803 | Antenna, Whip | 26419 | AT892/PRC-25 | Ea. | 1 |
| 5895-01-073-6839 | Power Supply/BA, PP-7566/GRR-8(V) | 14632 | WJ-8640-1/BC | Ea. | 1 |
| N/A | Battery, Nickel Cadmium | 09823 | BB-5864 | Ea. | 10 |
| N/A | Publication N/S TM 11-5825-278-12-2 | 80058 | N/A | Ea. | 1 |
| N/A | Publication N/S TM 11-5895-1227-14-1 | 80058 | N/A | Ea. | 1 |



NOTES

1. DUAL BAND FOR 5-30MHz AND 20-250MHz OPTIONS.

Figure 3-1. Type WJ-8640-1 Functional Block Diagram

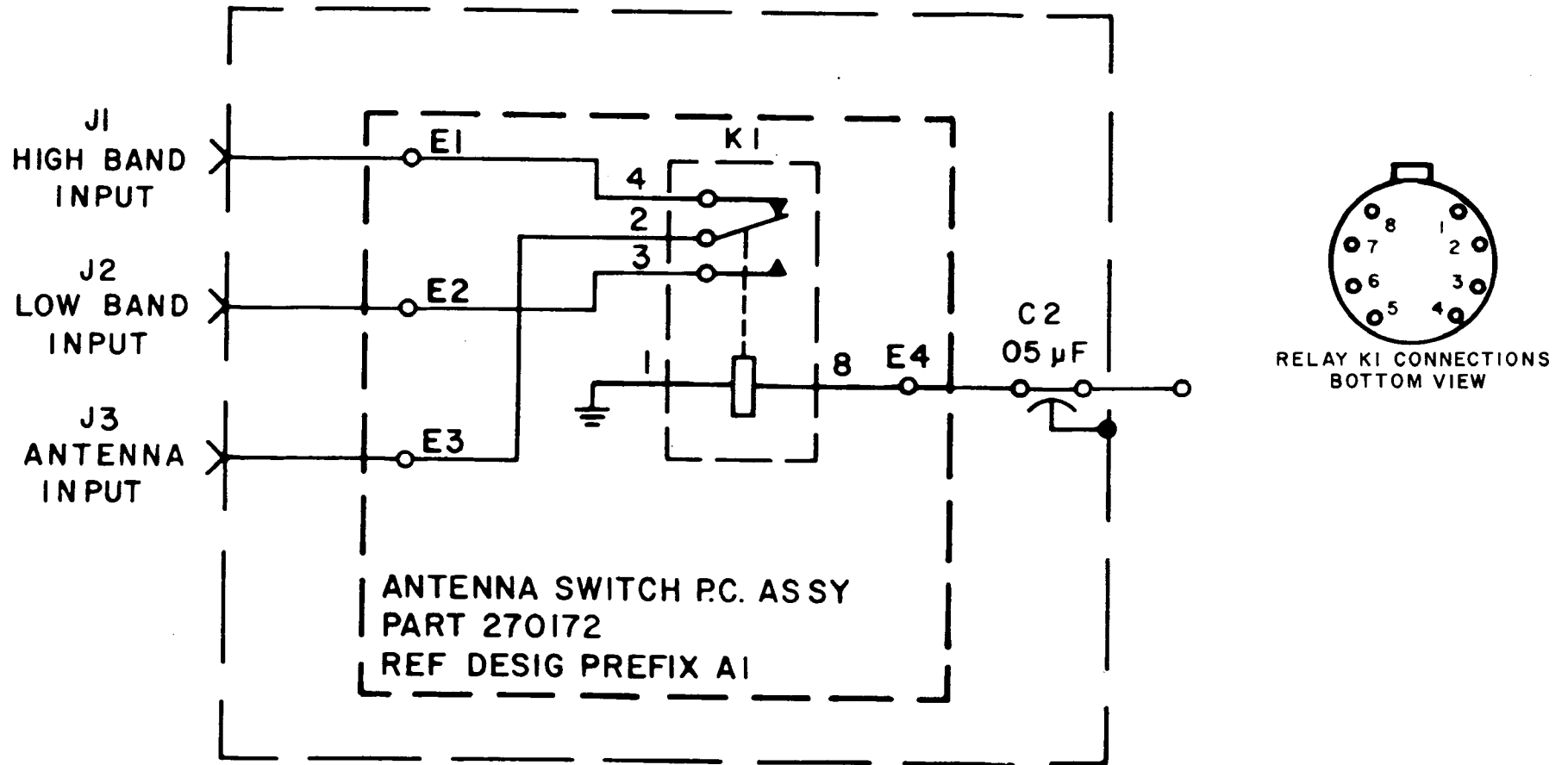


Figure 6-1. Type 791783 Antenna Switch Assembly (A1), Schematic Diagram 24924

- NOTES:
 1. UNLESS OTHERWISE SPECIFIED, CAPACITANCE IS IN μ F.
 2. S1 AND S2 ARE CONTROLLED FROM THE MAIN CHASSIS FRONT PANEL.
 3. SWITCH S2 IS SHOWN IN EXTREME COUNTERCLOCKWISE POSITION AND IS VIEWED FROM END OPPOSITE CONTROL KNOB. ARROW INDICATES CW ROTATION OF CONTROL KNOB.

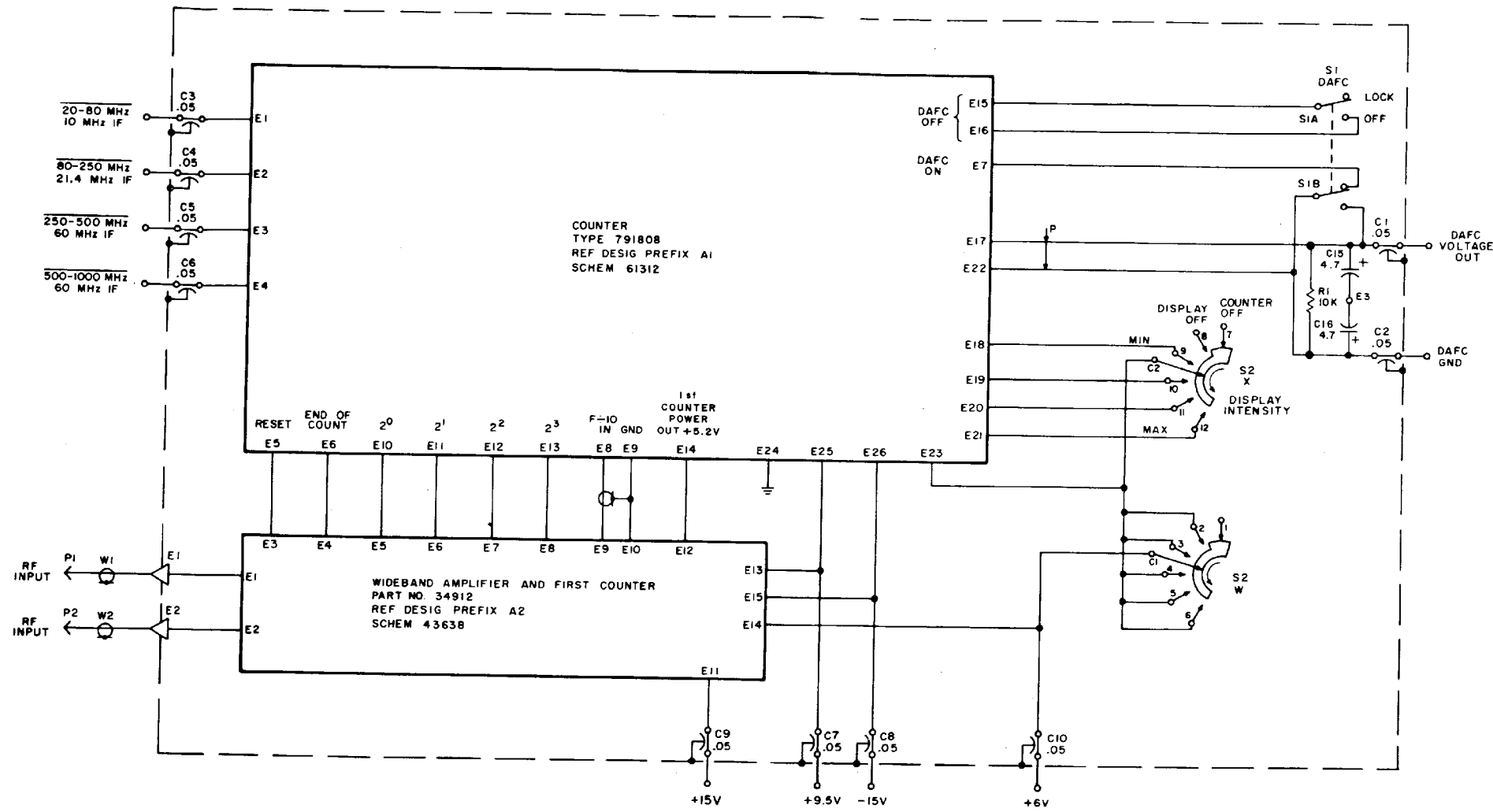


Figure 6-2. Type 791806 Counter Module (A3), Schematic Diagram 43636

NOTES:

1. RESISTANCE IS IN OHMS,
±1%, 1/10W.

2. PIN ARRANGEMENT FOR U1 & U2
IS SHOWN BELOW:

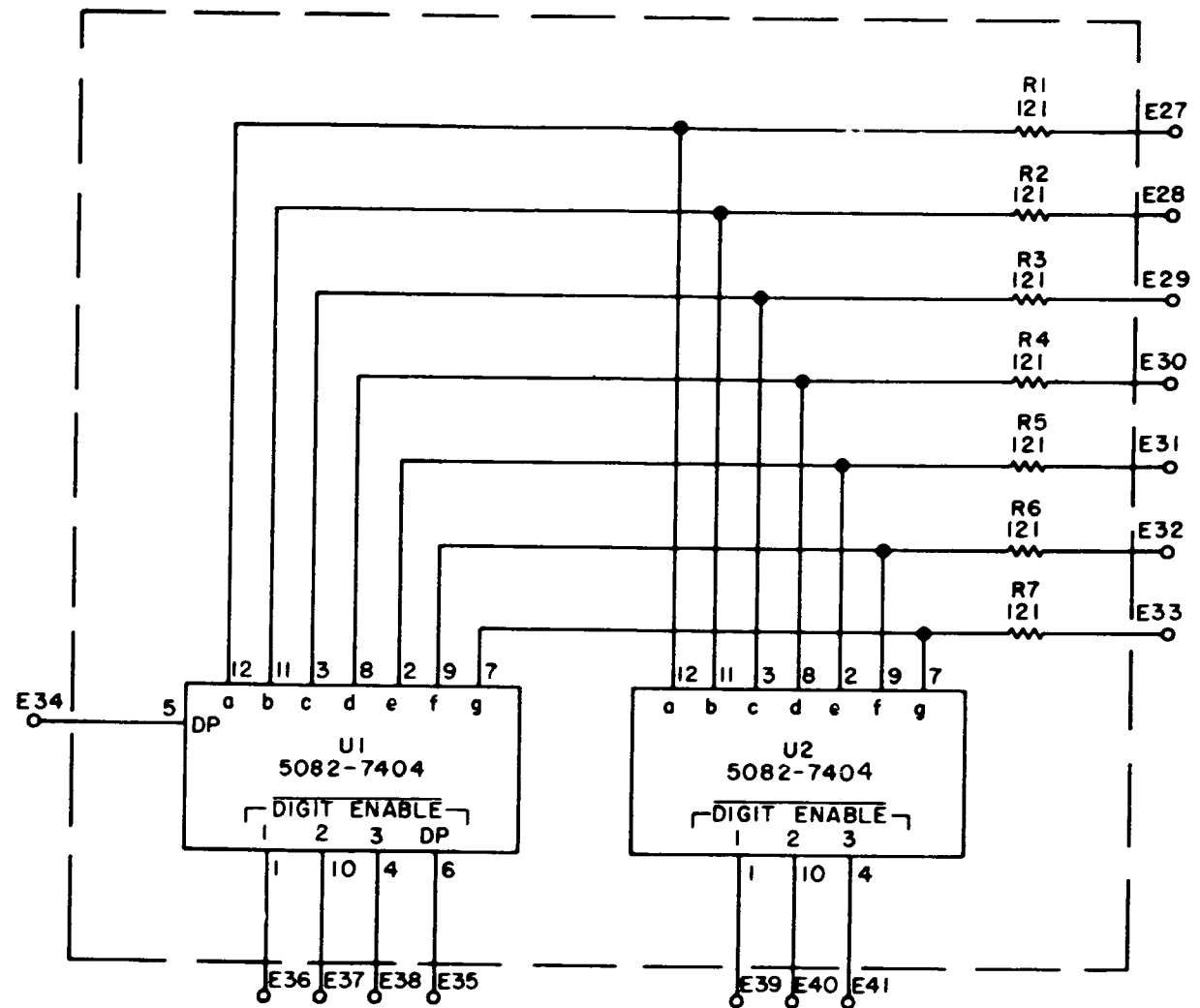
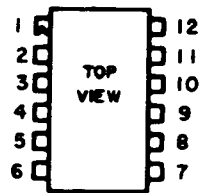
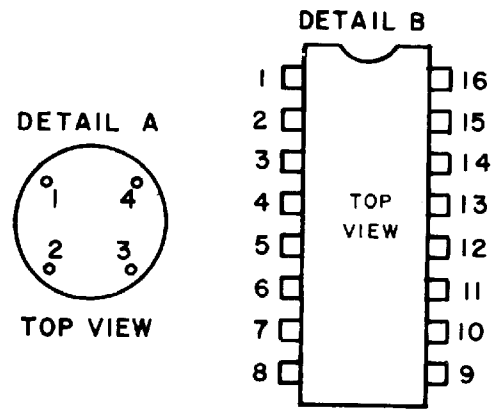


Figure 6-4. Part 24947 Display Board (A3A1A1), Schematic Diagram 34891

Courtesy of <http://BlackRadios.terryo.org>

| HIGHEST REF DESIG USED | REF DESIG NOT USED |
|------------------------|--------------------|
| C25 Q9 | Q4 |
| CR6 R50 | Q5 |
| E15 T1 | CR 4 |
| FB8 U4 | R16, 17, 18 |
| L10 | |



NOTES:
 1. UNLESS OTHERWISE SPECIFIED:
 a) RESISTANCE IS IN OHMS, ±1%, 1/10W
 b) CAPACITANCE IS IN pF.
 2. PIN ARRANGEMENTS ARE SHOWN AS FOLLOWS:
 U1, U2 - DETAIL A; U3, U4 - DETAIL B.

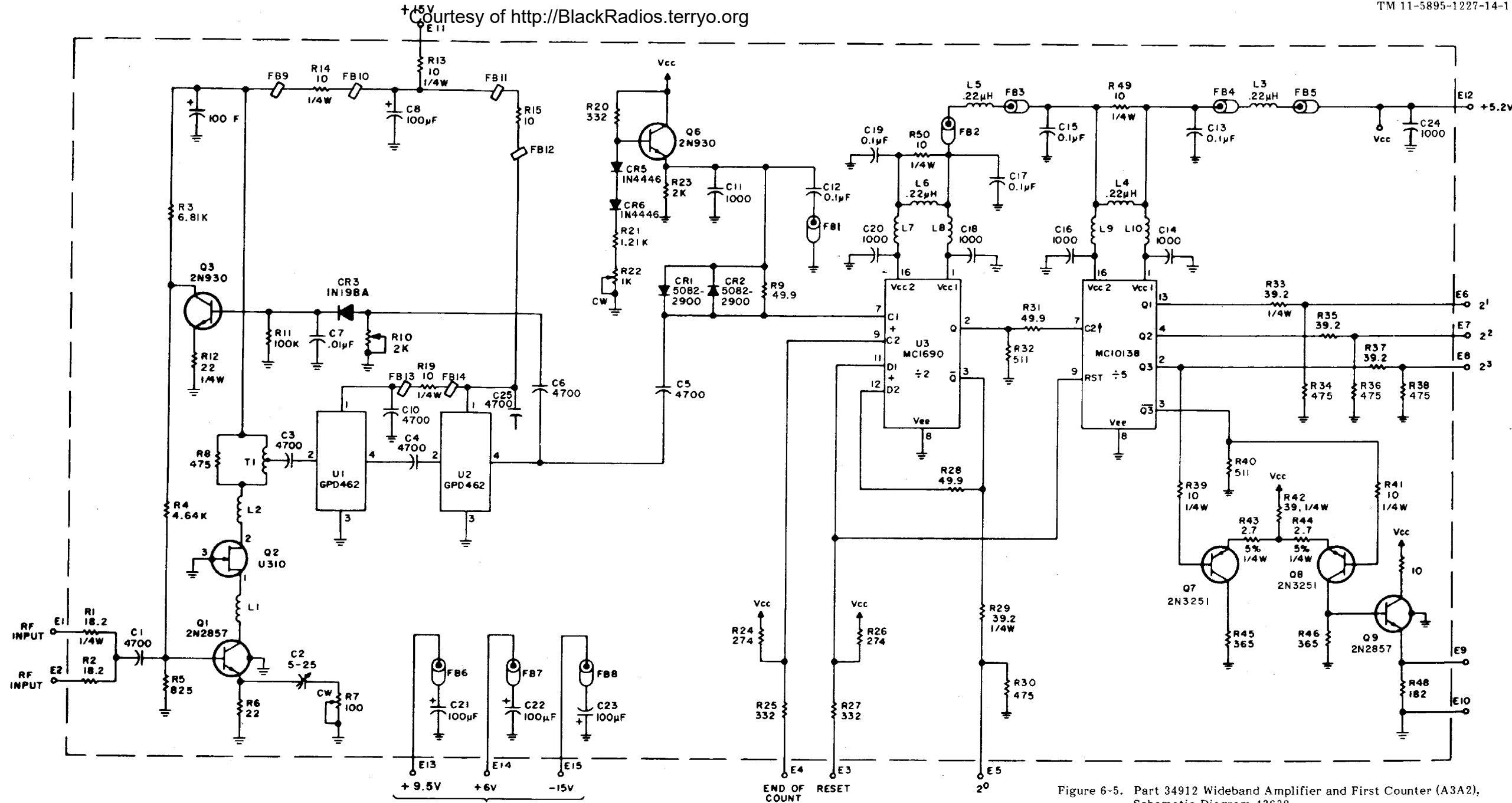


Figure 6-5. Part 34912 Wideband Amplifier and First Counter (A3A2), Schematic Diagram 43638

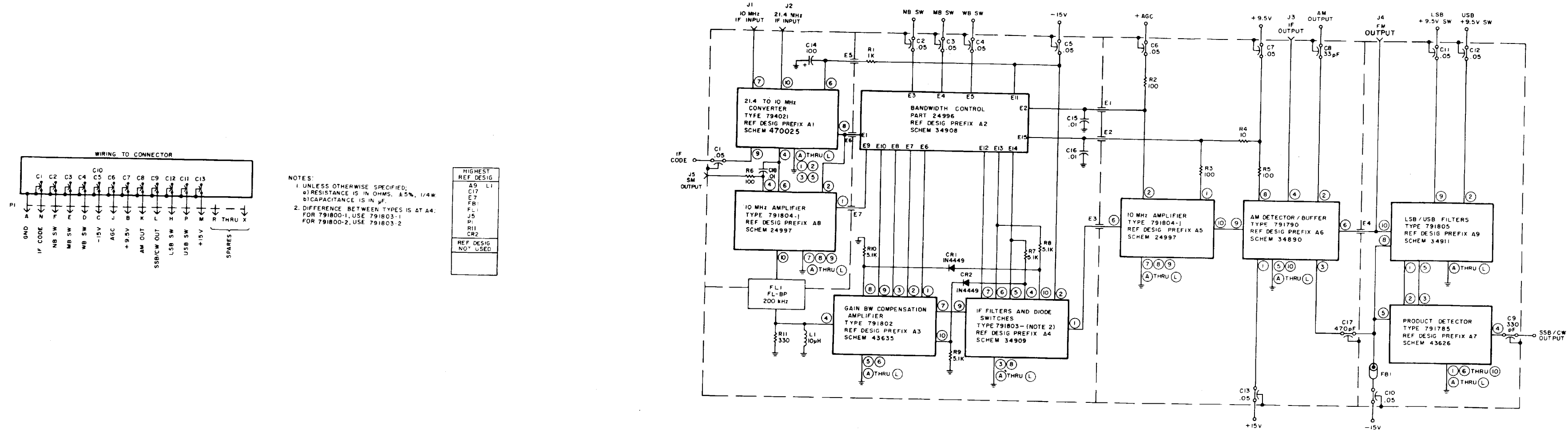


Figure 6-6. Type 791800-1 IF Demodulator (A4), Schematic Diagram 43632

- NOTE
- UNLESS OTHERWISE SPECIFIED.
 - RESISTANCE IS IN OHMS, $\pm 1\%$, 1/10W
 - CAPACITANCE IS IN μF .
 - NOMINAL VALUE, FINAL VALUE FACTORY SELECTED.

| HIGHEST REF DESIG USED | REF DESIG NOT USED |
|--|--------------------|
| C15 C1 L4 U1 Y1 Q2 R16 | |

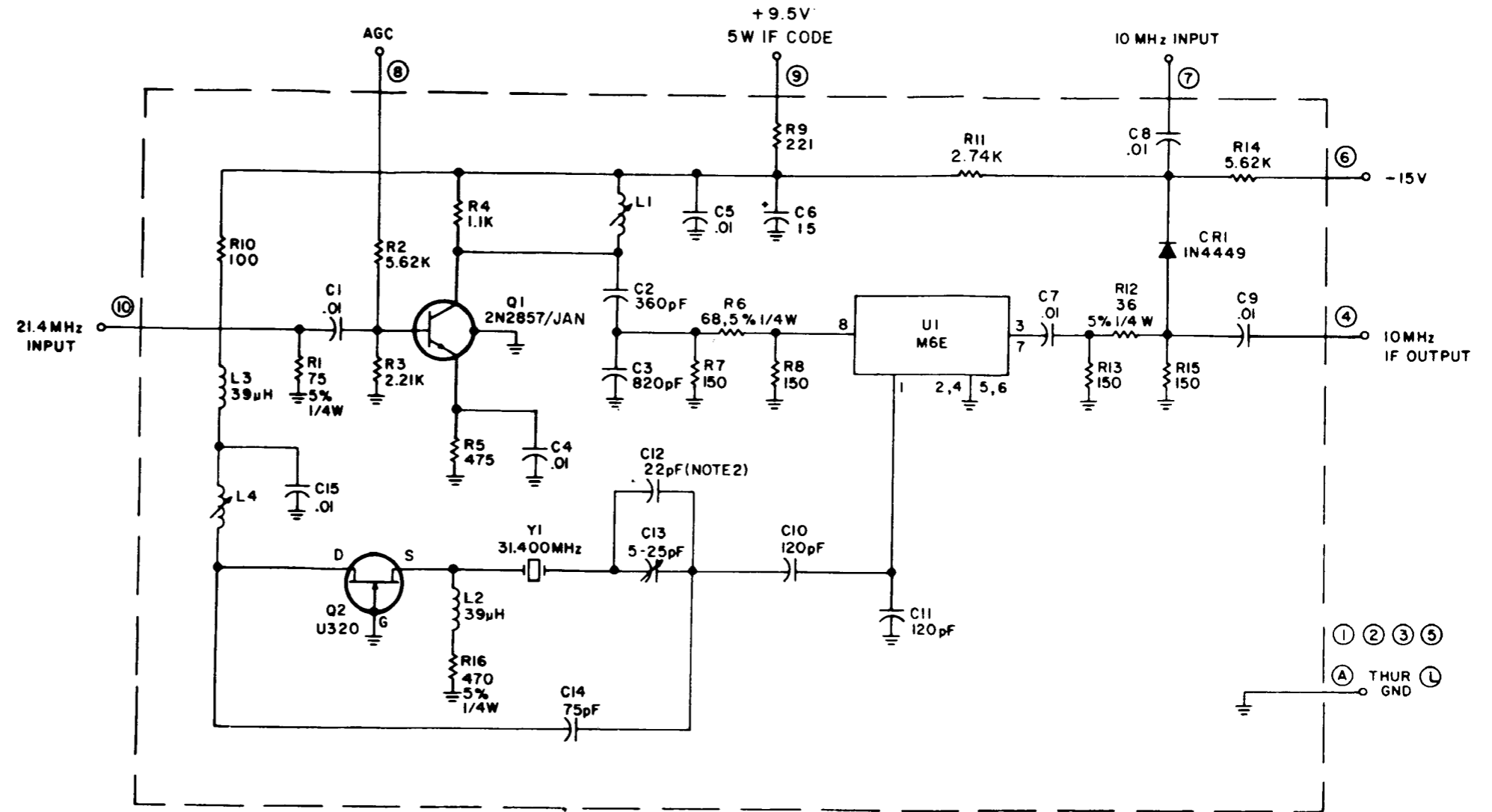


Figure 6-7. Type 794021 21.4/10 MHz Converter (A4A1), Schematic Diagram 470025

NOTE:

- 1. UNLESS OTHERWISE SPECIFIED:
 - A) RESISTANCE IS IN OHMS, +/- 1%, 1/10W
 - B) CAPACITANCE IS IN UF

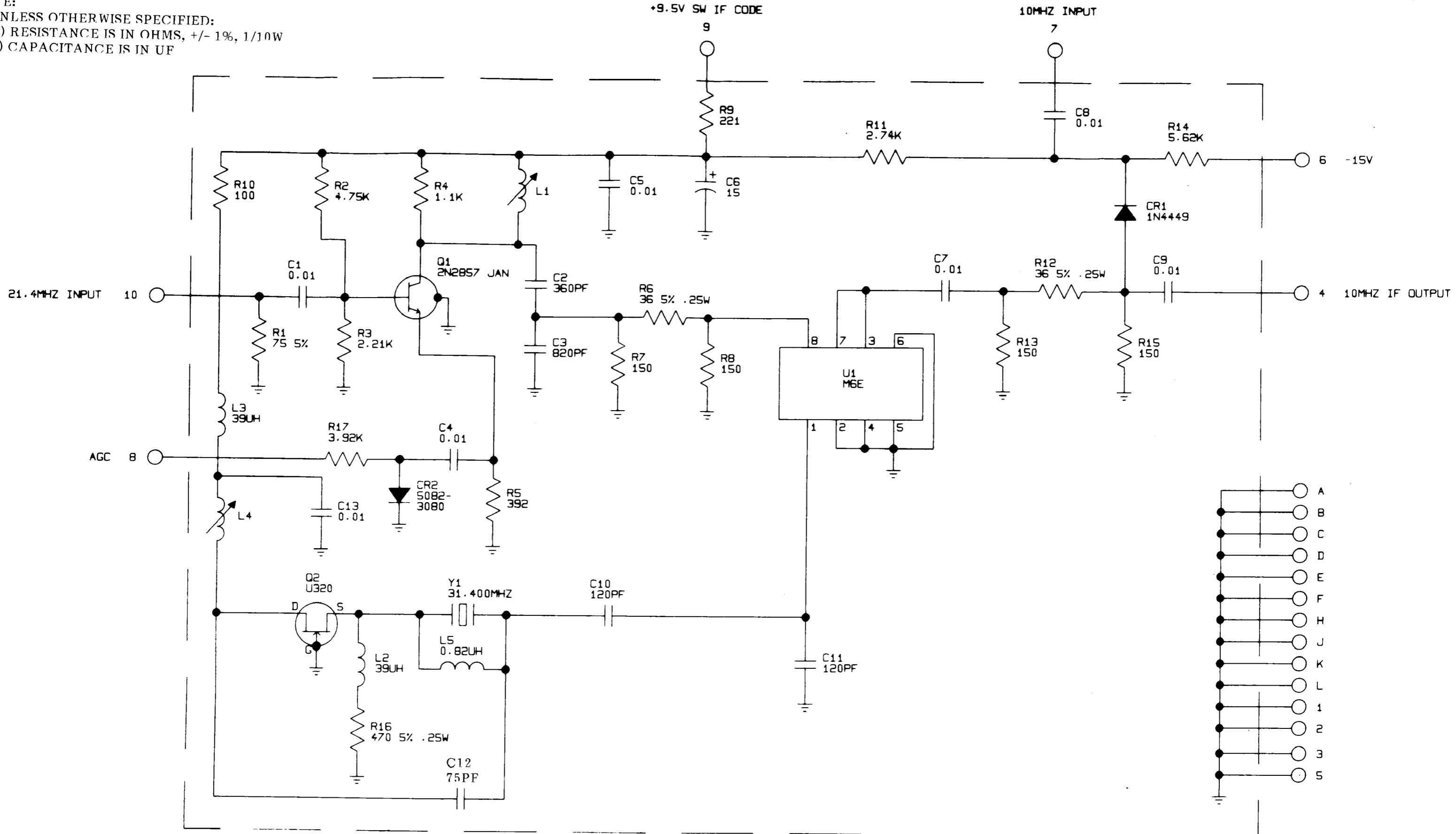


Figure 6-7.1. Type 794485-1 21.4/10 MHz Converter (A4A1), Schematic Diagram 471060

NOTE:
 UNLESS OTHERWISE SPECIFIED:
 a) RESISTANCE IS IN OHMS, $\pm 1\%$, 1/10W.
 b) CAPACITANCE IS IN μF .

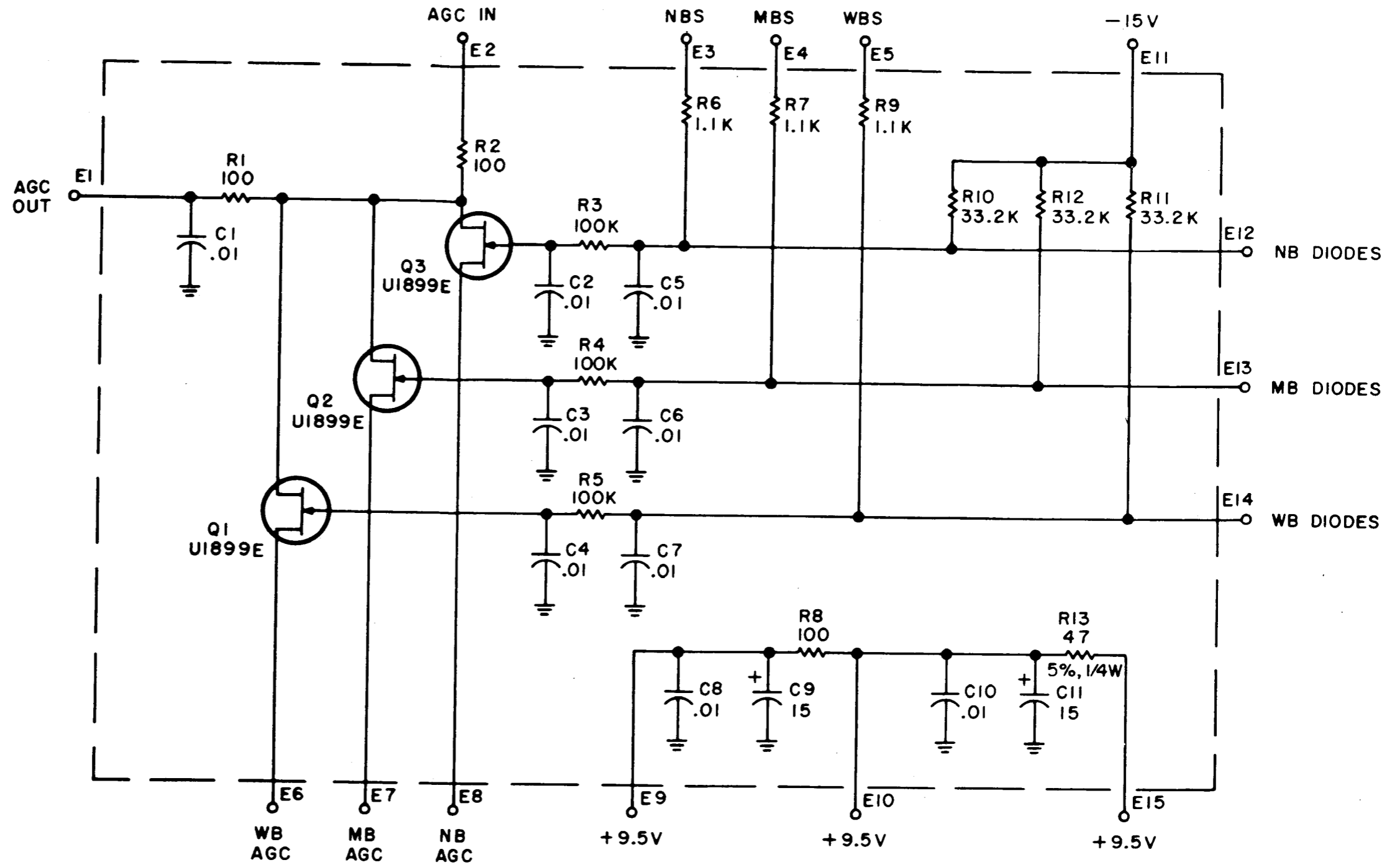


Figure 6-8. Part 24996 Bandwidth Control (A4A2), Schematic Diagram 34908
 6-17/(6-18 blank)

- NOTES:
 1. UNLESS OTHERWISE SPECIFIED:
 a) RESISTANCE IS IN OHMS, $\pm 1\%$, 1/10W.
 b) CAPACITANCE IS IN μF .
 2. CW ON POTENTIOMETERS INDICATES FULL
 CLOCKWISE POSITION OF ACTUATOR.

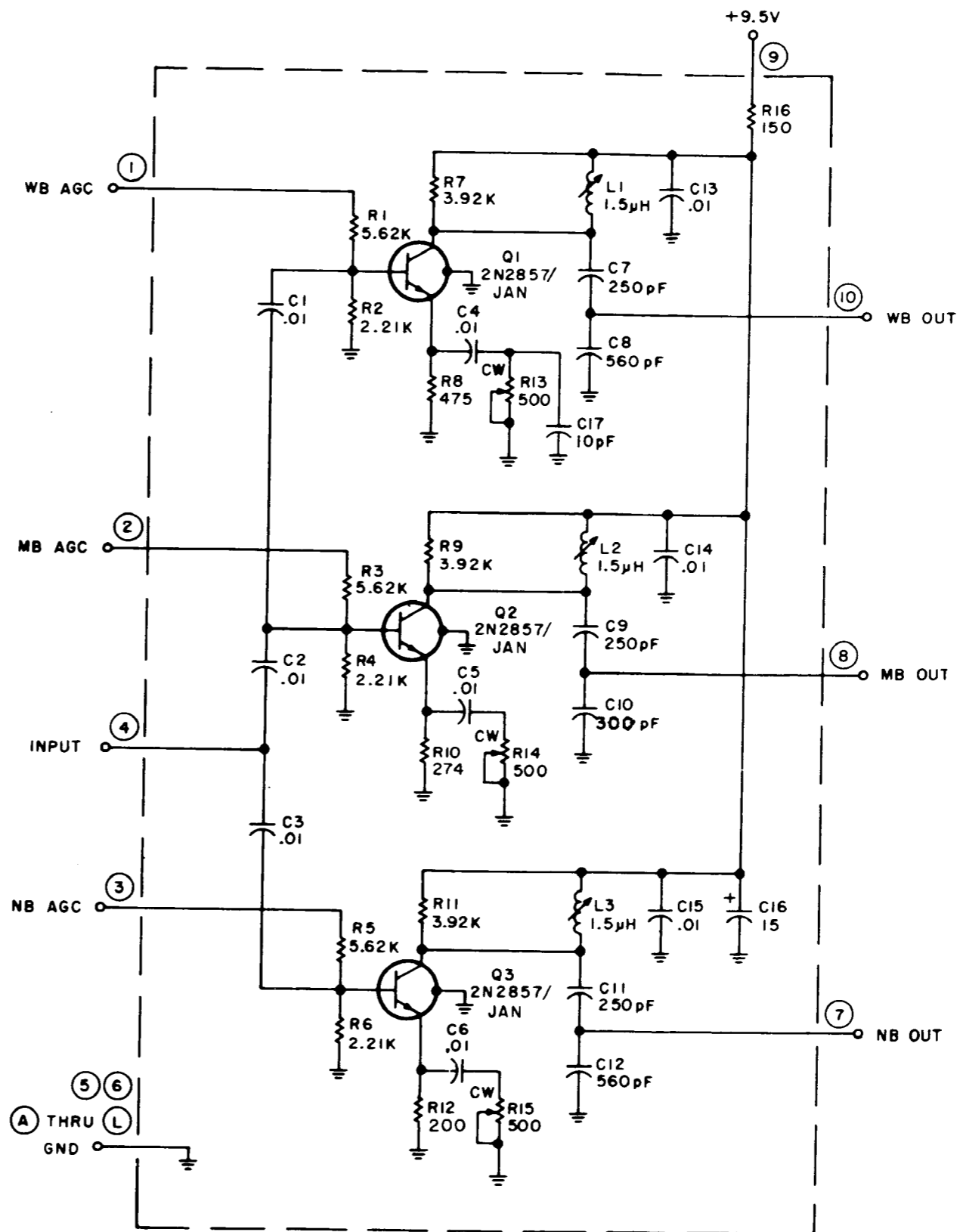


Figure 6-9. Type 791802 Gain BW Compensation Amplifier (A4A3), Schematic Diagram 43635

| TABLE I | | |
|----------|--------|--------|
| TYPE NO. | FL1 | FL2 |
| 791803-1 | 10 kHz | 50 kHz |
| 791803-2 | 5 kHz | 20 kHz |
| 791803-3 | 20kHz | 50 kHz |

- NOTES:
- UNLESS OTHERWISE SPECIFIED:
 a) RESISTANCE IS IN OHMS, $\pm 1\%$, 1/10W.
 b) CAPACITANCE IS IN μF .
 - DIFFERENCE BETWEEN TYPES IS GIVEN IN TABLE I.

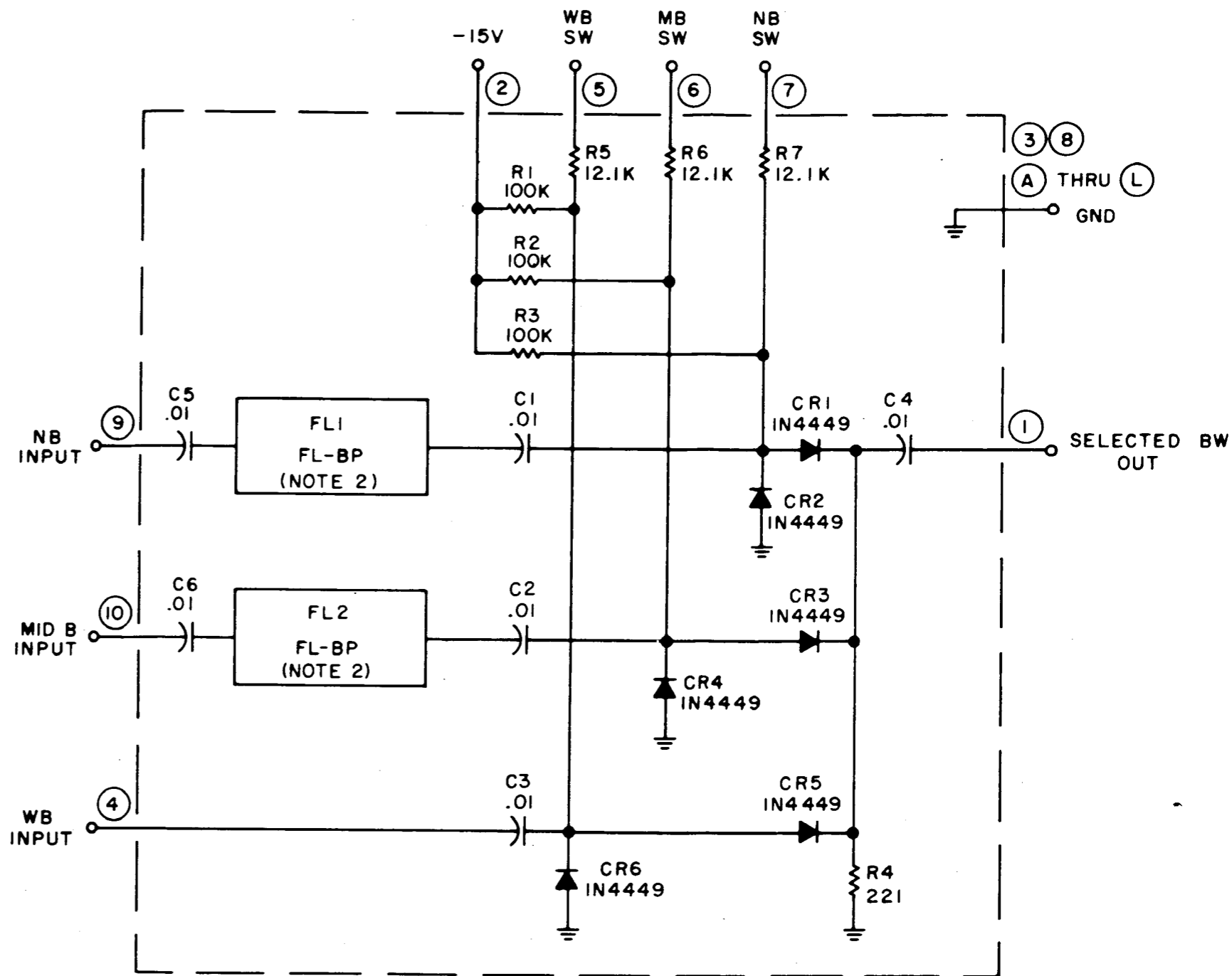


Figure 6-10. Type 791803-1 IF Filter and Diode Switches (A4A4), Schematic Diagram 34909

NOTES:

1. UNLESS OTHERWISE SPECIFIED:
 a) RESISTANCE IS IN OHMS, $\pm 1\%$, .1W.
 b) CAPACITANCE IS IN pF.
2. DIFFERENCE BETWEEN TYPES IS LISTED IN TABLE.
3. NOMINAL VALUE; FINAL VALUE FACTORY SELECTED.

| TYPE | R4 | R7 | R3 | R6 | C4 | C5 | L1 | R9 |
|----------|-----|-------|--------|-------|-----|-----|----------------------|-------|
| 791804-1 | 274 | 1K | 3.92 K | 10 * | 250 | 560 | 7107-15, 1.5 μ H | 2.7 * |
| 791804-2 | 475 | OMIT | 2.55K | 10 * | 250 | 560 | 7107-15, 1.5 μ H | 2.7 * |
| 791804-3 | 475 | 680 * | 5.6K * | 150 * | 120 | 160 | 7107-20, 3.9 μ H | 15 * |
| 791804-4 | 475 | 680 * | 5.6K * | 51 * | 120 | 160 | 7107-20, 3.9 μ H | 15 * |

* 5%, 1/4W

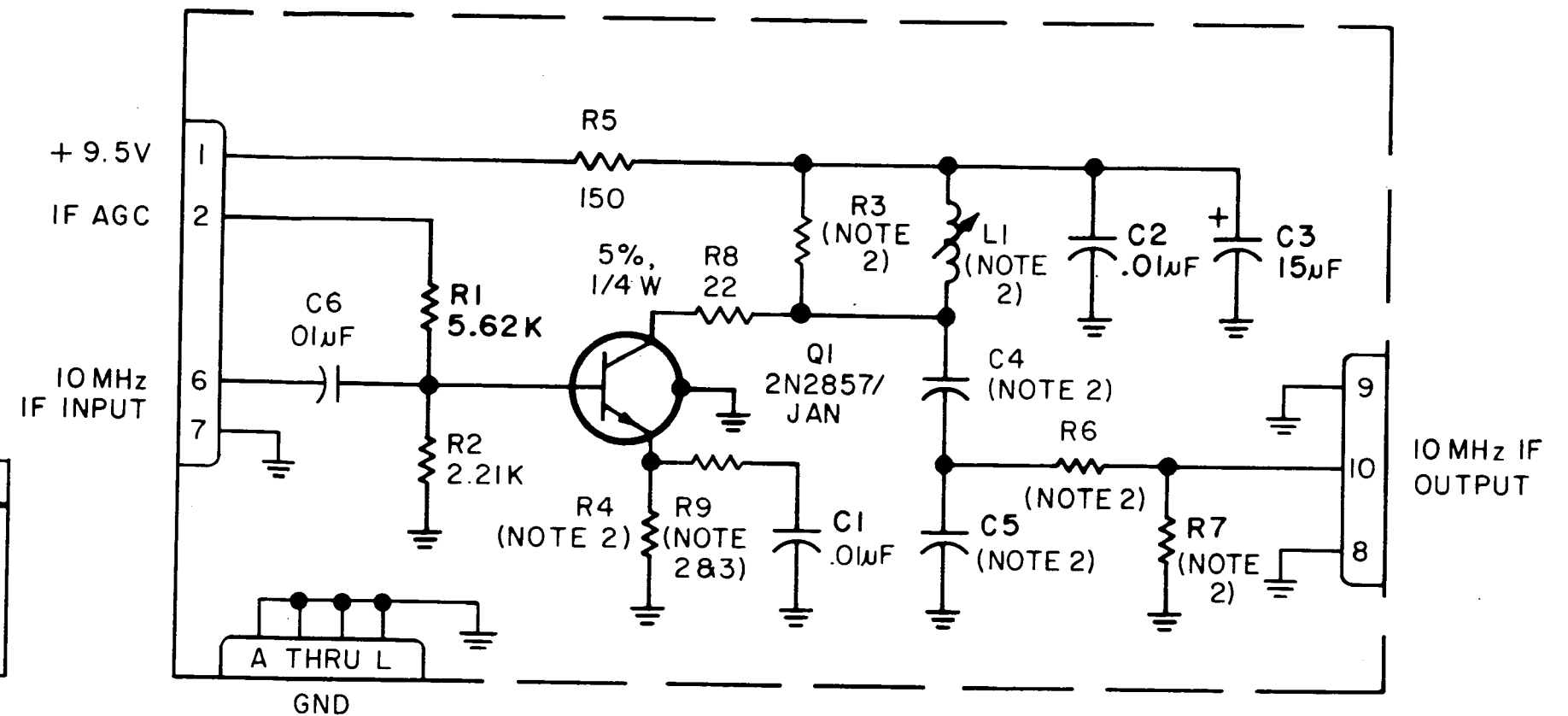


Figure 6-11. Type 791804-1 10 MHz Amplifier (A4A5, A4A8), Schematic Diagram 24997

NOTE:
 1. UNLESS OTHERWISE SPECIFIED:
 a) RESISTANCE IS IN OHMS, $\pm 1\%$, 1/10W.
 b) CAPACITANCE IS IN μF .
 2. NOMINAL VALUE, FINAL VALUE FACTORY SELECTED.

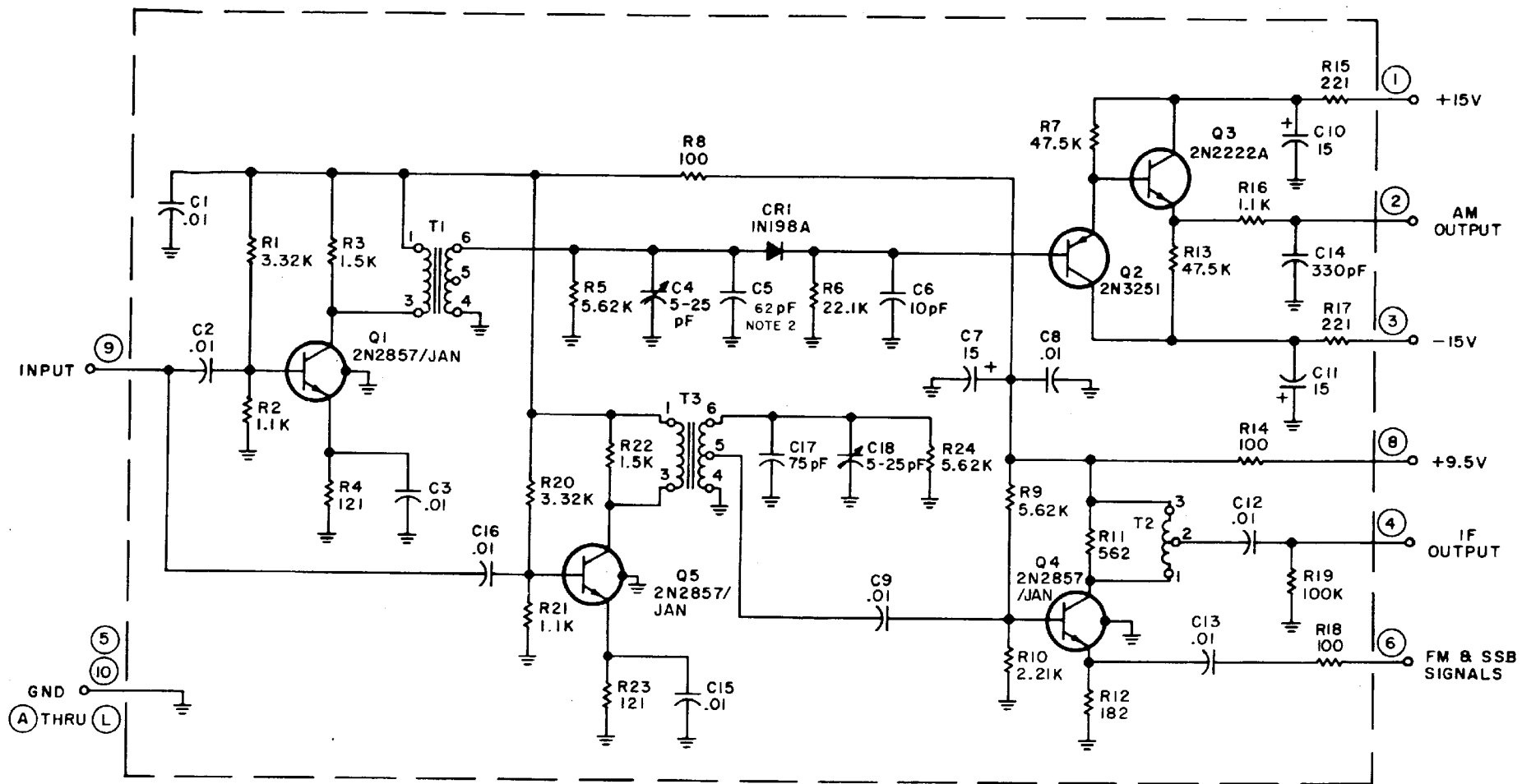
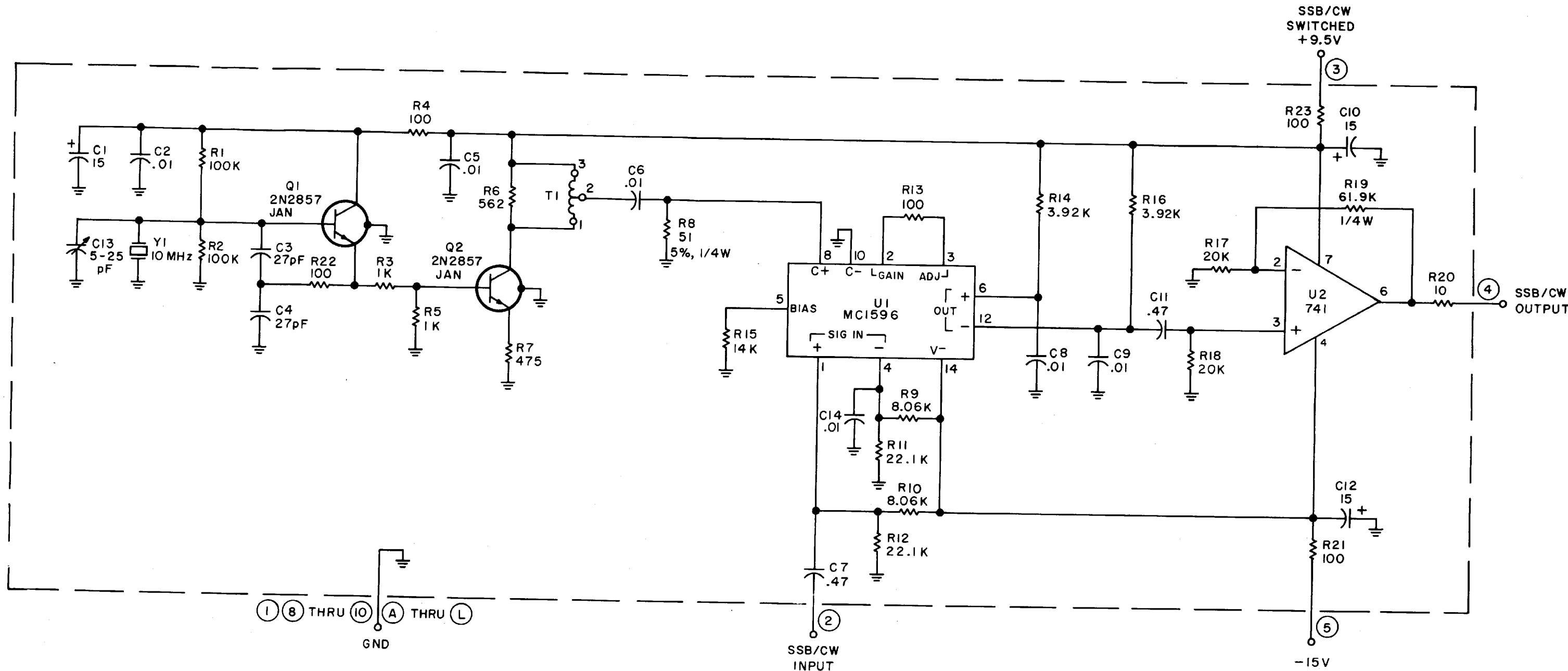
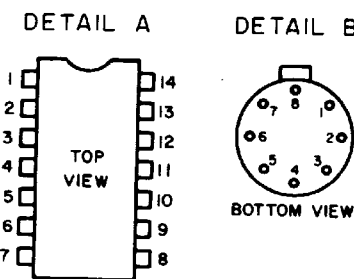


Figure 6-12. Type 791790 AM Detector/Buffer (A4A6), Schematic Diagram 34890

| HIGHEST REF DESIG | REF DESIG NOT USED |
|-------------------|--------------------|
| C14 | |
| Q2 | |
| R23 | |
| T1 | |
| U2 | |
| Y1 | |



- NOTES:
- UNLESS OTHERWISE SPECIFIED:
 - RESISTANCE IS IN OHMS, $\pm 1\%$, 1/10W.
 - CAPACITANCE IS IN μF .
 - PIN ARRANGEMENT FOR U1 IS SHOWN IN DETAIL A, PIN ARRANGEMENT FOR U2 IS SHOWN IN DETAIL B.

Figure 6-13. Type 791785 Product Detector (A4A7), Schematic Diagram 43626

NOTE:
 UNLESS OTHERWISE SPECIFIED:
 a) RESISTANCE IS IN OHMS, $\pm 1\%$, 1/10W.
 b) CAPACITANCE IS IN μF .

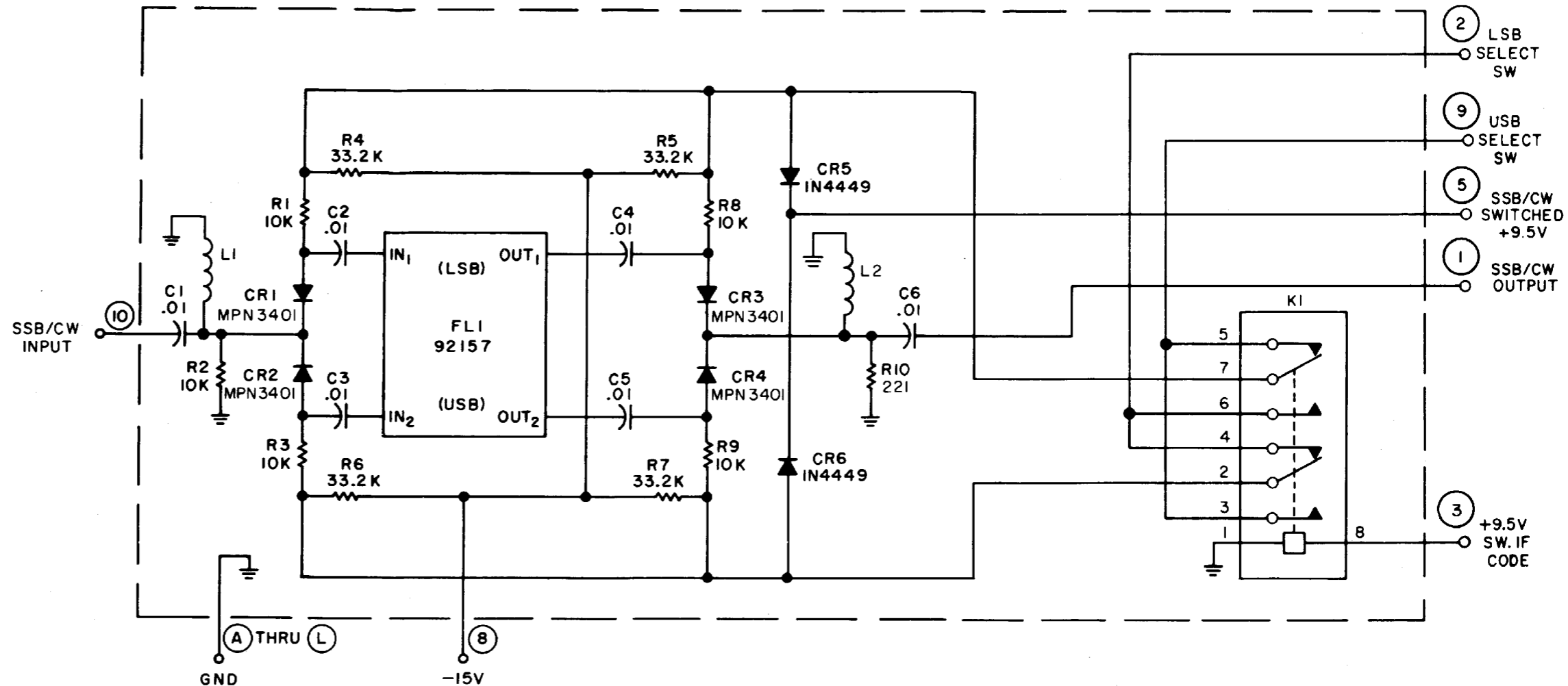
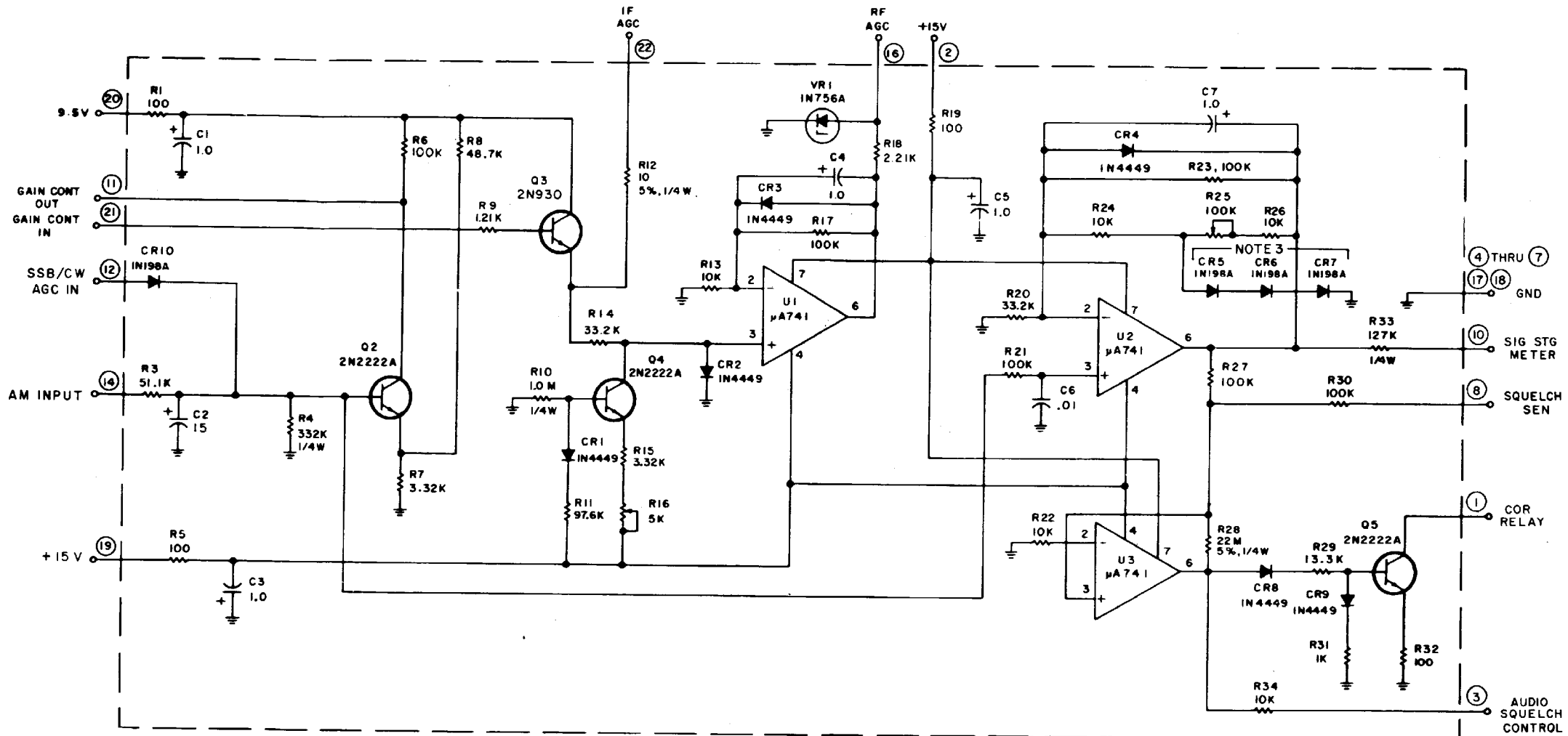


Figure 6-14. Type 791805 LSB/USB Filter (A4A9), Schematic Diagram 34911



NOTES:

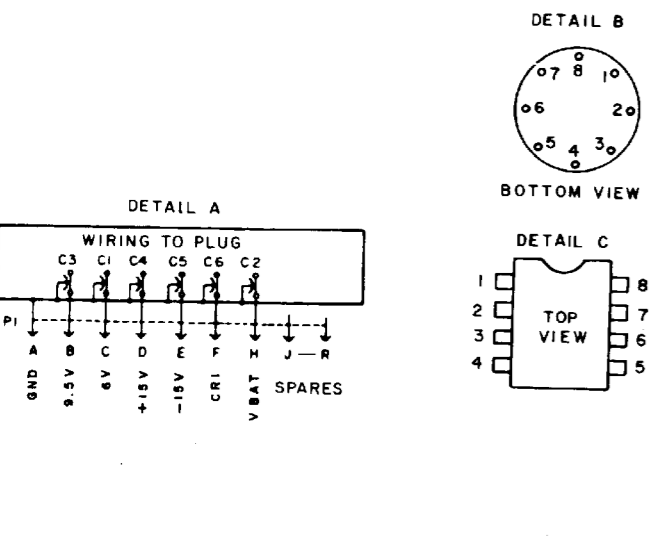
1. UNLESS OTHERWISE SPECIFIED:
 - a) RESISTANCE IS IN OHMS ±1%, 1W
 - b) CAPACITANCE IS μF.
2. LEAD ARRANGEMENT FOR U1, U2 & U3 IS SHOWN IN DETAIL A.
3. NOMINAL TYPE, FINAL TYPE, FACTORY SELECTED BETWEEN IN4449 & IN198A.

DETAIL A



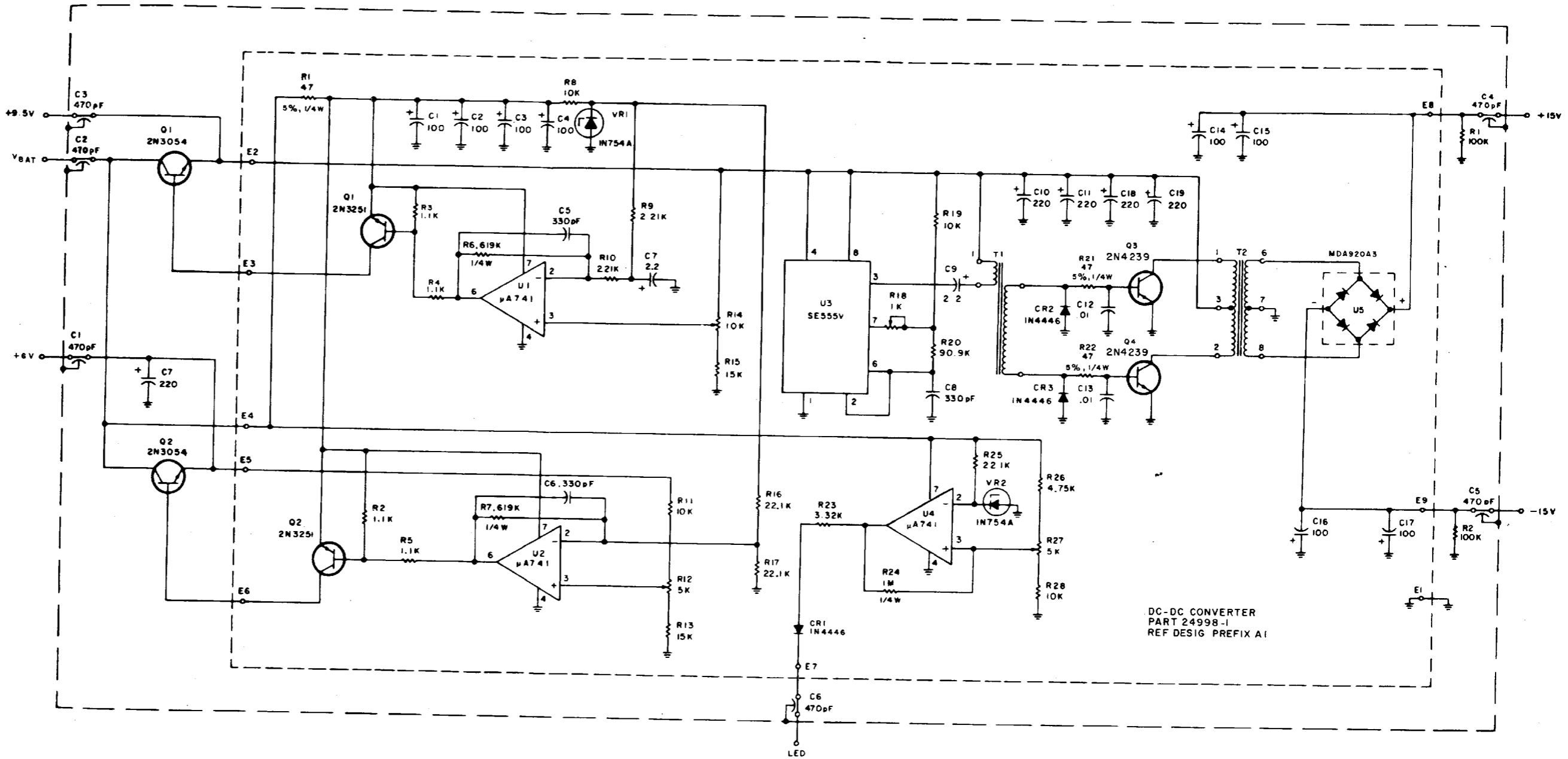
| HIGHEST REF DESIG USED | REF DESIG NOT USED |
|--------------------------------------|--------------------|
| C7 CR10 Q5 R34 U3 VR1 | Q1 R2 |

Figure 6-15. Type 791817 AGC Squelch (A5), Schematic Diagram 43645



| HIGHEST REF DESIG USED | REF DESIG NOT USED |
|------------------------|--------------------|
| A1 | |
| Q4 | C7 |
| R28 | Q2 |
| T2 | P1 |
| U5 | A1 |
| VR2 | R2 |
| C19 | |
| E9 | |
| CR3 | |

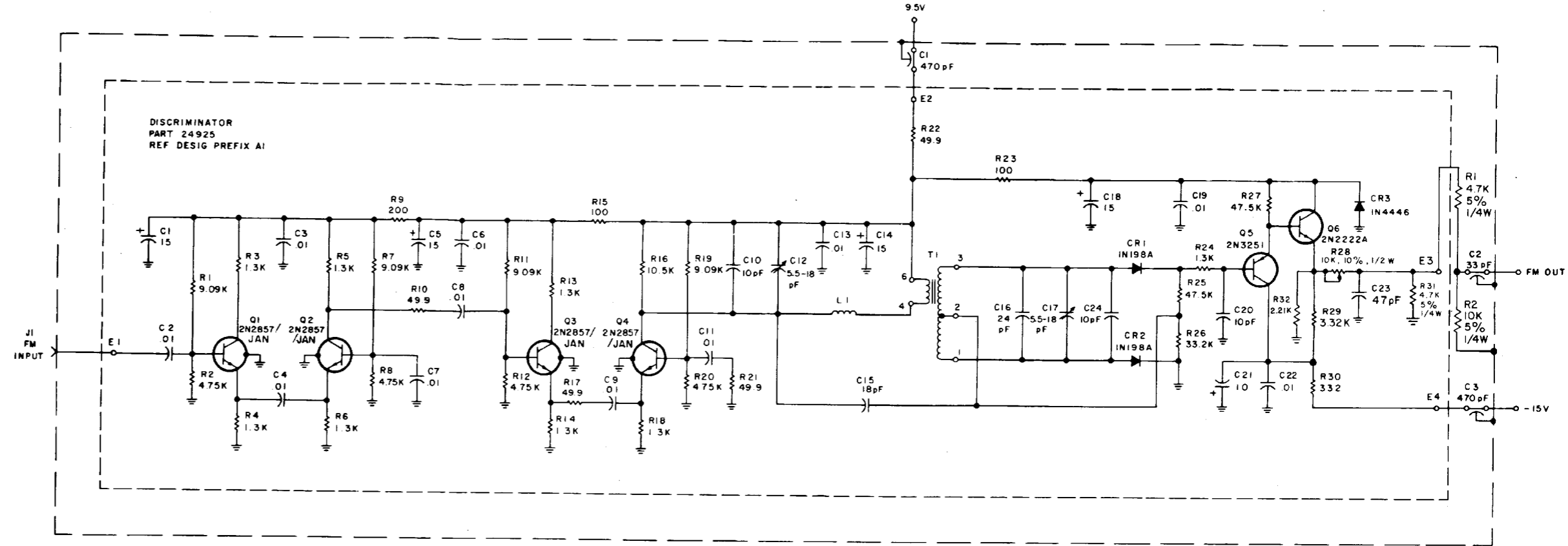
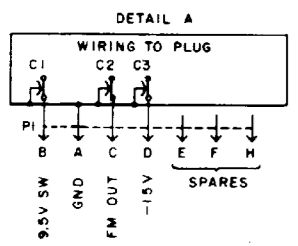
- NOTES:
- UNLESS OTHERWISE SPECIFIED
 a) RESISTANCE IS IN OHMS, $\pm 1\%$, 1/4 W
 b) CAPACITANCE IS μF
 - FOR WIRING TO PLUG SEE DETAIL A
 - LEAD ARRANGEMENT FOR U1, U2 & U4 IS SHOWN IN DETAIL B, U3 IS SHOWN IN DETAIL C.
 - CW ON POTENTIOMETERS INDICATES FULL CLOCKWISE POSITION OF ACTUATOR.



DC-DC CONVERTER
 PART 24998-1
 REF DESIG PREFIX A1

Figure 6-16. Type 791794 DC-DC Converter (A6), Schematic Diagram 51264
 6-33/(6-34 blank)

- NOTES**
- 1 UNLESS OTHERWISE SPECIFIED
 - a) ALL RESISTANCE IS IN OHMS ±1%, 1/10W
 - b) CAPACITANCE IS μF.
 - 2 FOR WIRING TO PLUG SEE DETAIL A.



| HIGHEST REF DESIG USED | REF DESIG NOT USED |
|------------------------|--------------------|
| A1 | |
| E4 | J1 |
| C24 | P1 |
| L1 | A1 |
| P1 | T1 |
| Q6 | |
| R31 | |
| CR3 | |

Figure 6-17. Type 791784 FM Discriminator (A7), Schematic Diagram 51253

| HIGHEST REF DESIG USED | REF DESIG NOT USED |
|------------------------|--------------------|
| C12 | |
| CR3 | |
| Q6 | |
| R30 | |
| U2 | |

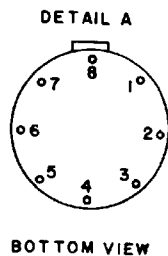


TABLE 1

| TYPE NO. | R7 | R8 |
|----------|-----|------|
| 7464-1 | 15K | 82K |
| 7464-2 | 39K | 160K |

- NOTES:
- UNLESS OTHERWISE SPECIFIED:
a) RESISTANCE IS IN OHMS, 1%, 1/4 W
b) CAPACITANCE IS μ F
 - LEAD ARRANGEMENT FOR U1 & U2 IS SHOWN IN DETAIL A.
 - DIFFERENCES BETWEEN TYPES AND VALUES ARE SHOWN IN TABLE 1.

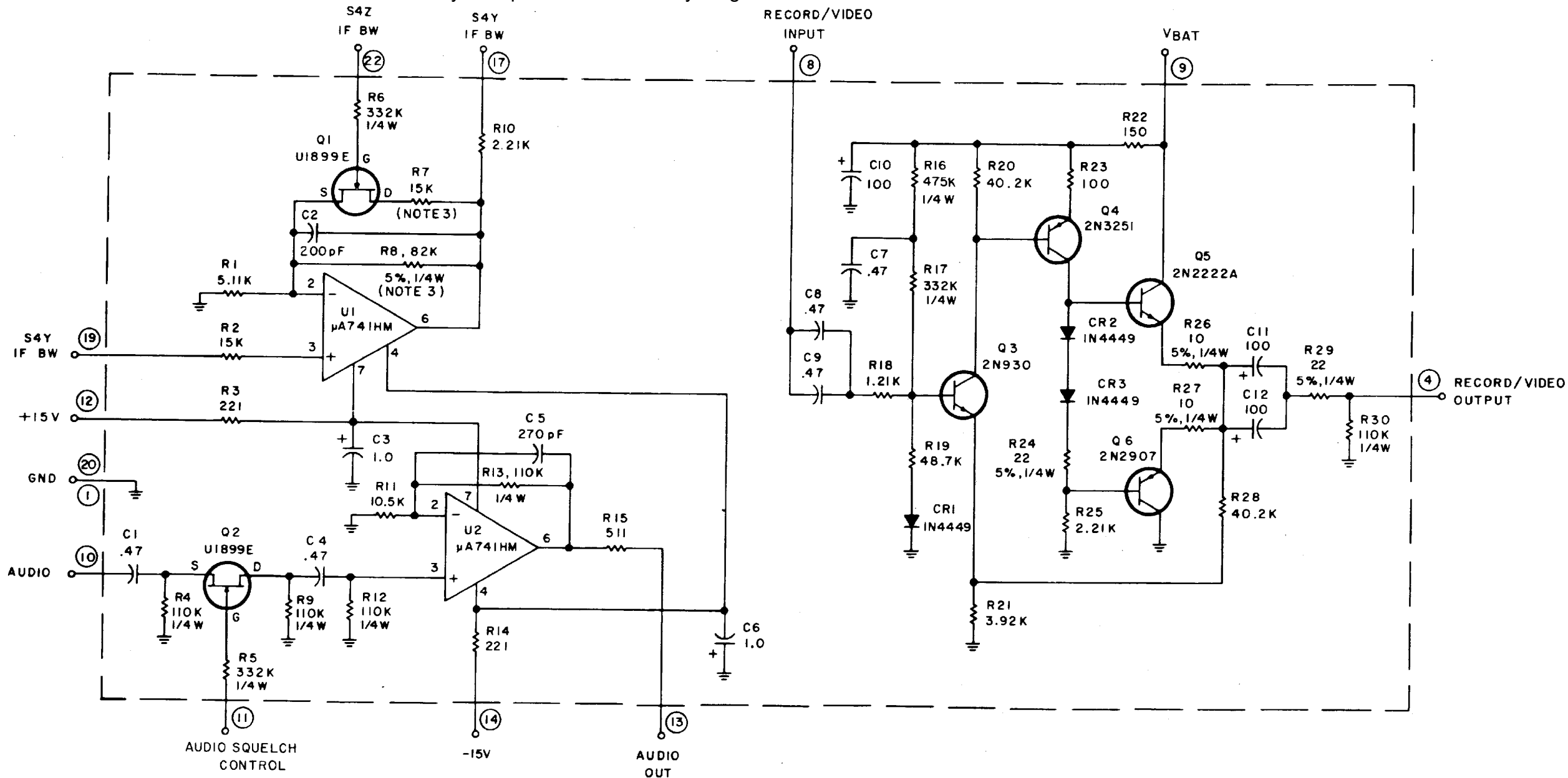


Figure 6-18. Type 7464 Audio/Record Amplifier (A8), Schematic Diagram 43627

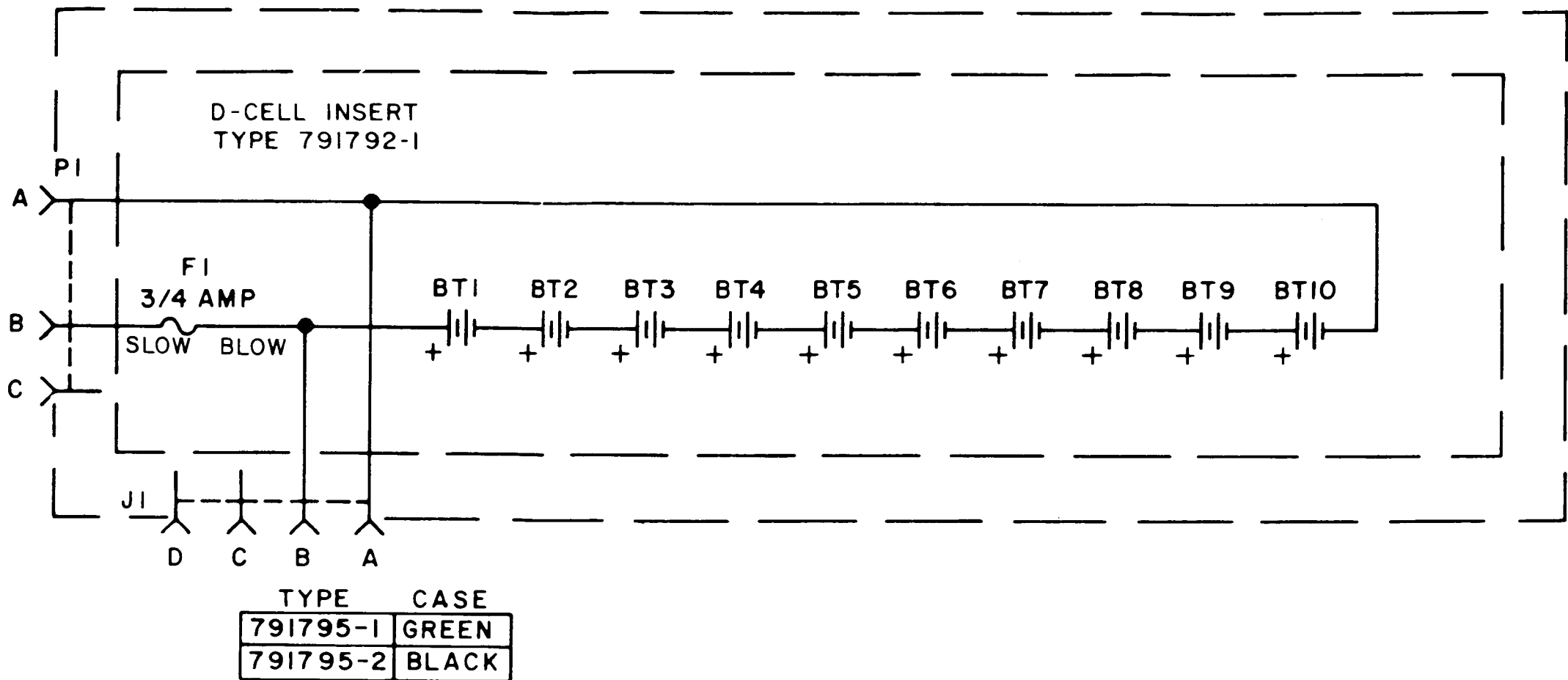
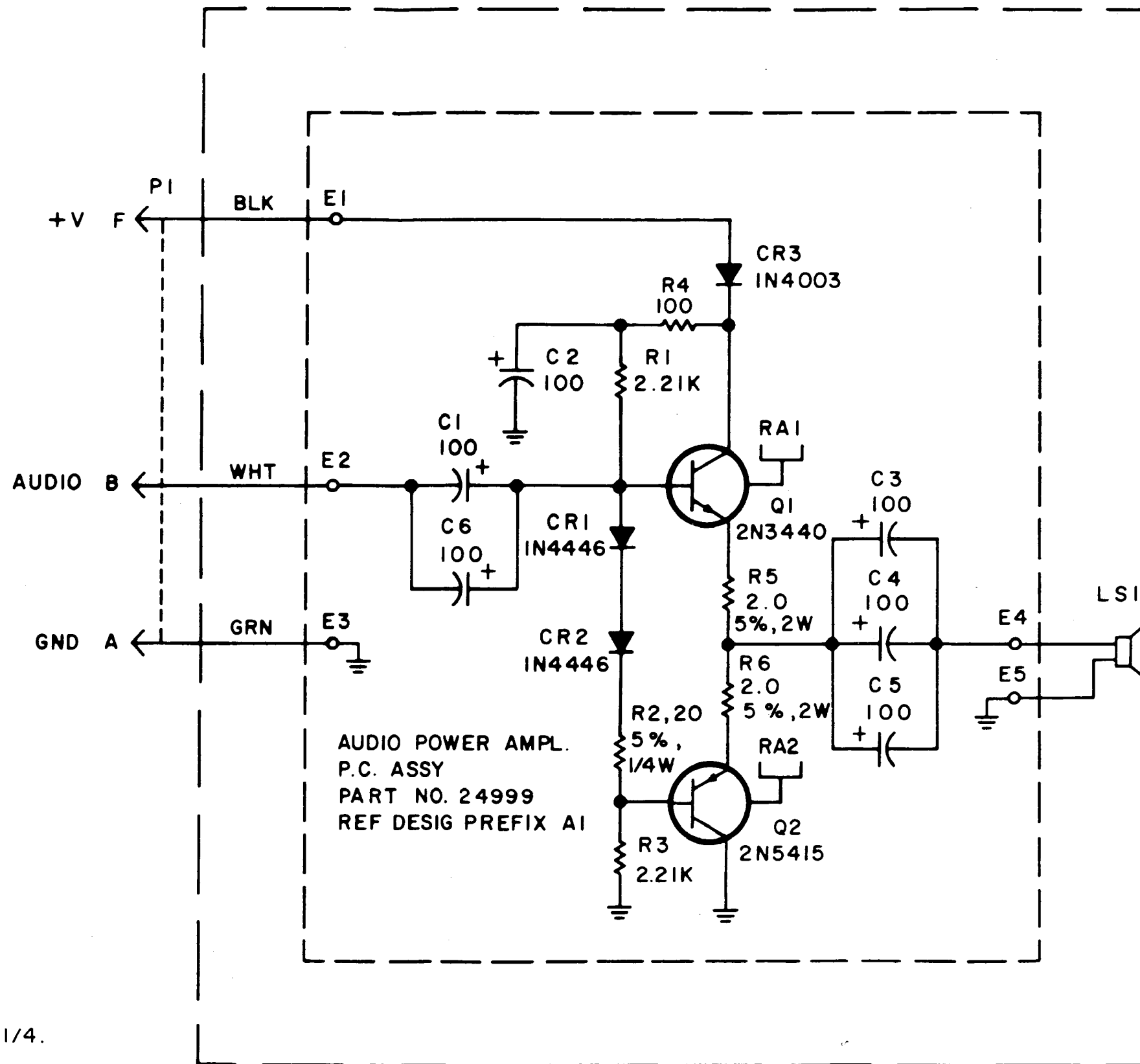


Figure 6-19. Type 791795-1 D-Cell Insert (A9), Schematic Diagram 24985



NOTES:

I. UNLESS OTHERWISE:

a) RESISTANCE IS IN OHMS, $\pm 1\%$, 1/4.

b) CAPACITANCE IS μF .

Figure 6-20. Type 791809-1 Front Panel Protective Cover With Speaker (A10), Schematic Diagram 34913

- NOTES:
- UNLESS OTHERWISE SPECIFIED:
a) RESISTANCE IS IN OHMS, $\pm 5\%$, 1/4 W.
b) CAPACITANCE IS IN μF .
 - DENOTE FRONT PANEL CONTROL.
 - CW ON POTENTIOMETERS INDICATES FULL CLOCKWISE POSITION OF ACTUATOR.
 - ROTARY SWITCHES ARE VIEWED FROM END OPPOSITE CONTROL KNOB, WITH CONTROL KNOB IN FULL CCW POSITION. LETTERS W, X, Y, Z DENOTE WAFER SEGMENTS. ARROW INDICATES CW ROTATION OF CONTROL KNOB (REAR VIEW).
 - TUNER ASSEMBLY IS SELECTED FOR DESIRED FREQUENCY RANGE AS DESCRIBED IN TABLE 'A'.
 - S3 IS MECHANICALLY GANGED TO R5 (SHOWN IN MID-POSITION) WHICH ACTUATES AGC FUNCTION ON FULL CW POSITION.
 - S7 IS MECHANICALLY GANGED TO R10 WHICH ACTUATES OFF FUNCTION ON FULL CCW POSITION.
 - NOT USED ARE PINS C, D, J, L, M, N, P, AND R.

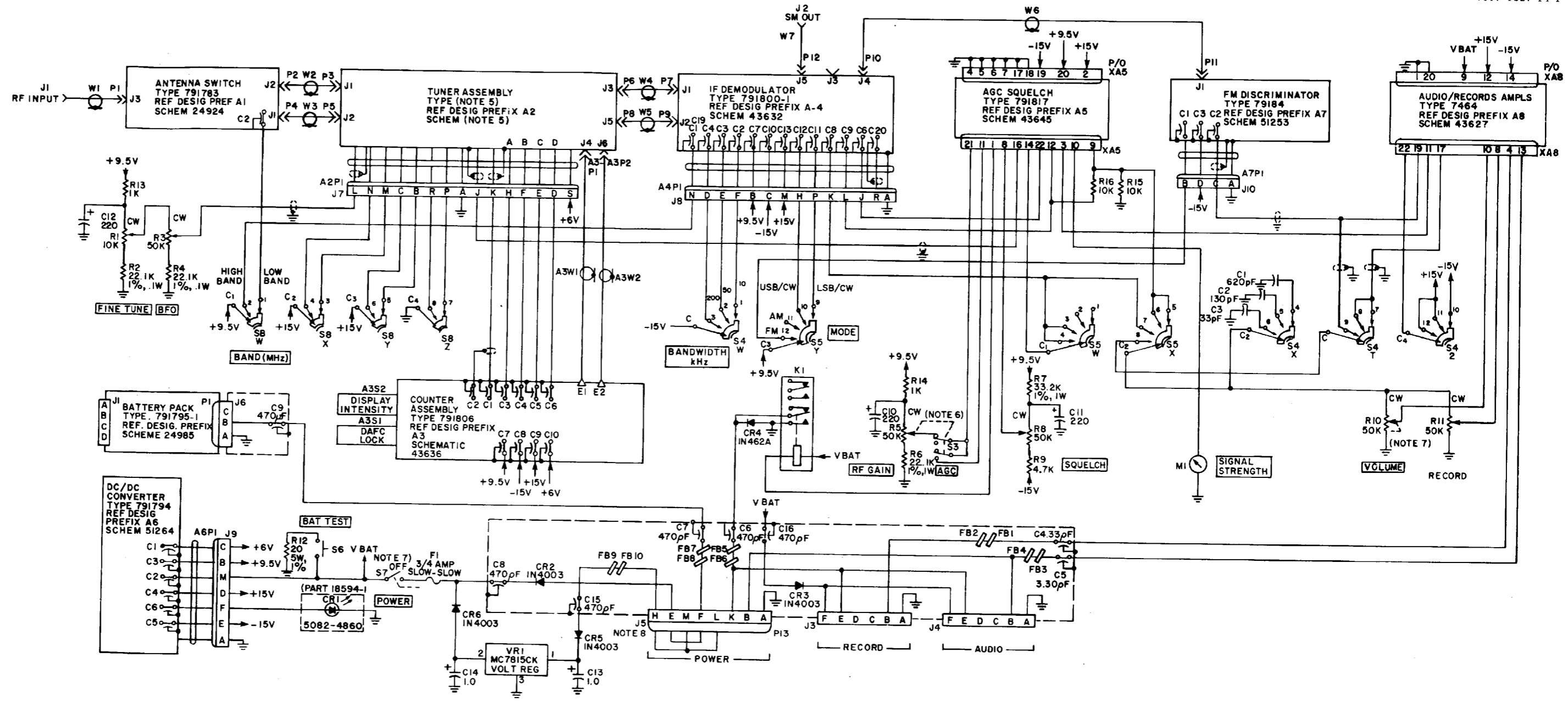
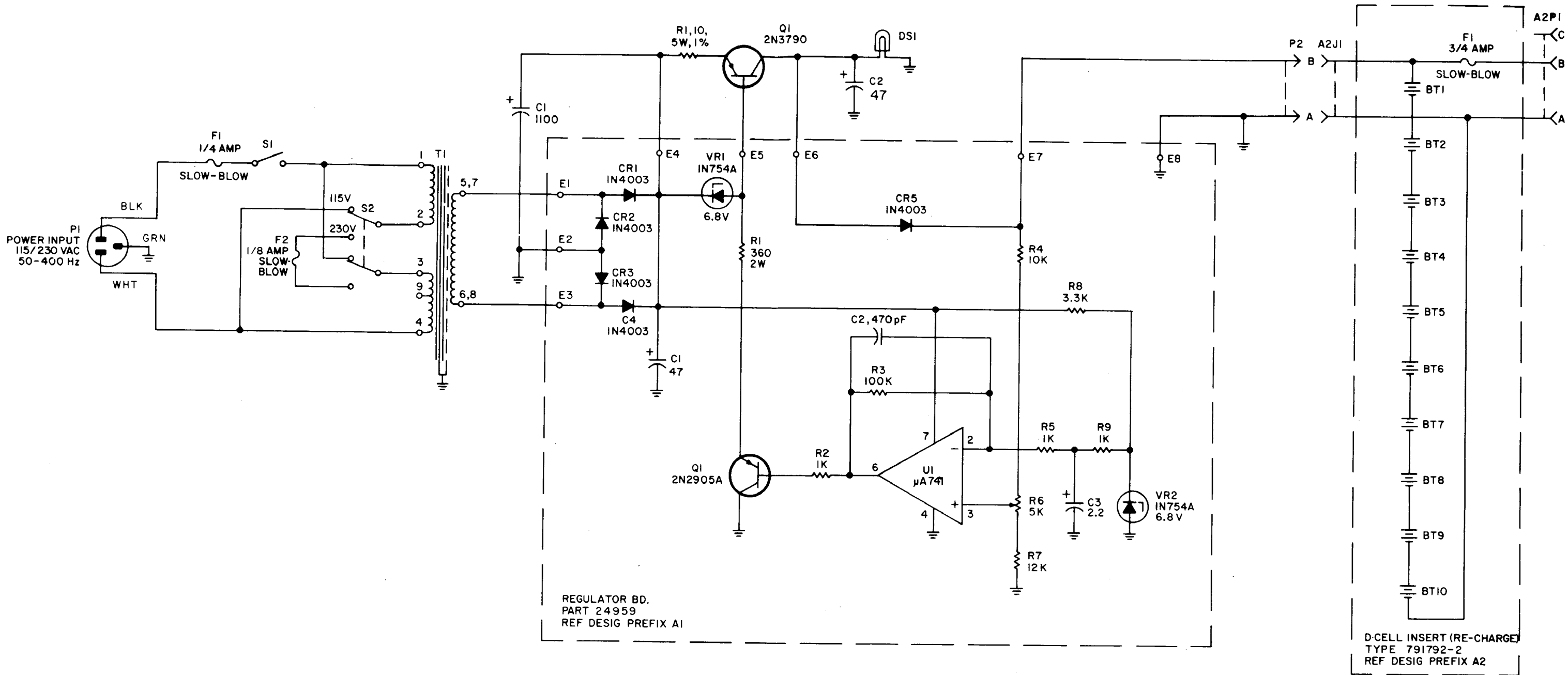


Figure 6-21. Type WJ-8640-1 VHF Portable Receiver, Main Chassis, Schematic Diagram 61299



NOTES:

1. UNLESS OTHERWISE SPECIFIED:
 - a) RESISTANCE IS IN OHMS, $\pm 5\%$, 1/4 W.
 - b) CAPACITANCE IS IN μF .
2. LEAD ARRANGEMENT FOR THE IC IS SHOWN IN DETAIL A.

DETAIL A

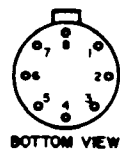


Figure 7-5. WJ-8640/BC Battery Charger, Main Chassis, Schematic Diagram 43618.

RECOMMENDED CHANGES TO EQUIPMENT TECHNICAL PUBLICATIONS



THEN... JOT DOWN THE DOPE ABOUT IT ON THIS FORM. CAREFULLY TEAR IT OUT. FOLD IT AND DROP IT IN THE MAIL!

SOMETHING WRONG WITH THIS PUBLICATION?

FROM (PRINT YOUR UNIT'S COMPLETE ADDRESS)
 Commander
 Stateside Army Depot
 ATTN: AMSTA-US
 Stateside, N.J. 07703-5007

DATE SENT
 10 July 1975

PUBLICATION NUMBER
 TM 11-5840-340-12

PUBLICATION DATE
 23 Jan 74

PUBLICATION TITLE
 Radar Set AN/PRC-76

BE EXACT PIN-POINT WHERE IT IS

| PAGE NO | PARA-GRAPH | FIGURE NO | TABLE NO |
|---------|------------|-----------|----------|
| 2-25 | 2-28 | | |
| 3-10 | 3-3 | | 3-1 |
| 5-6 | 5-8 | | |
| | | F03 | |

IN THIS SPACE TELL WHAT IS WRONG AND WHAT SHOULD BE DONE ABOUT IT:

Recommend that the installation antenna alignment procedure be changed throughout to specify a 2° IFF antenna lag rather than 1°.

REASON: Experience has shown that with only a 1° lag, the antenna servo system is too sensitive to wind gusting in excess of 25 knots, and has a tendency to rapidly accelerate and decelerate as it hunts, causing strain to the drive train. Hunting is minimized by adjusting the lag to 2° without degradation of operation.

Item 5, Function column. Change "2 db" to "3db."

REASON: The adjustment procedure for the TRANS POWER FAULT indicator calls for a 3 db (500 watts) adjustment to light the TRANS POWER FAULT indicator.

Add new step f.1 to read, "Replace cover plate removed in step e.1, above."

REASON: To replace the cover plate.

Zone C 3. On J1-2, change "+24 VDC to "+5 VDC."

REASON: This is the output line of the 5 VDC power supply. +24 VDC is the input voltage.

TEAR ALONG PERFORATED LINE

PRINTED NAME, GRADE OR TITLE AND TELEPHONE NUMBER
 SSG I. M. DeSpirito 999-1776

SIGN HERE

FILL IN YOUR
UNIT'S ADDRESS

FOLD BACK

DEPARTMENT OF THE ARMY

OFFICIAL BUSINESS

SAMPLE

Commander
US Army Communications-Electronics Command
and Fort Monmouth
ATTN: AMSEL-ME-MP
Fort Monmouth, New Jersey 07703-5000

TEAR ALONG PERFORATED LINE

RECOMMENDED CHANGES TO EQUIPMENT TECHNICAL PUBLICATIONS



THEN...JOT DOWN THE DOPE ABOUT IT ON THIS FORM. CAREFULLY TEAR IT OUT, FOLD IT AND DROP IT IN THE MAIL.

SOMETHING WRONG WITH THIS PUBLICATION?

FROM: (PRINT YOUR UNIT'S COMPLETE ADDRESS)

DATE SENT

PUBLICATION NUMBER

TM 11-5895-1227-14-1

PUBLICATION DATE

1 May 1988

PUBLICATION TITLE

Receiver R-2200/GRR-8(V)

BE EXACT PIN-POINT WHERE IT IS

PAGE NO

PARA-GRAPH

FIGURE NO.

TABLE NO

IN THIS SPACE TELL WHAT IS WRONG AND WHAT SHOULD BE DONE ABOUT IT:

IF WE LONG PRIORITY IN

PRINTED NAME GRADE OR TITLE AND TELEPHONE NUMBER

SIGN HERE

DA FORM 1 JUL 79 2028-2

PREVIOUS EDITIONS ARE OBSOLETE

P.S. IF YOUR OUTFIT WANTS TO KNOW ABOUT YOUR RECOMMENDATION MAKE A CARBON COPE OF THIS AND GIVE IT TO YOUR HEADQUARTERS

FILL IN YOUR
UNIT'S ADDRESS

FOLD BACK

DEPARTMENT OF THE ARMY

OFFICIAL BUSINESS

Commander
US Army Communications-Electronics Command
and Fort Monmouth
ATTN: AMSEL-ME-MP
Fort Monmouth, New Jersey 07703-5000

TEAR ALONG PERFORATED LINE

RECOMMENDED CHANGES TO EQUIPMENT TECHNICAL PUBLICATIONS



THEN...JOT DOWN THE DOPE ABOUT IT ON THIS FORM. CAREFULLY TEAR IT OUT, FOLD IT AND DROP IT IN THE MAIL.

SOMETHING WRONG WITH THIS PUBLICATION?

FROM: (PRINT YOUR UNIT'S COMPLETE ADDRESS)

DATE SENT

PUBLICATION NUMBER

TM 11-5895-1227-14-1

PUBLICATION DATE

1 May 1988

PUBLICATION TITLE

Receiver R-2200/GRR-8(V)

BE EXACT PIN-POINT WHERE IT IS

PAGE NO.

PARA-GRAPH

FIGURE NO.

TABLE NO.

IN THIS SPACE TELL WHAT IS WRONG AND WHAT SHOULD BE DONE ABOUT IT:

U. S. ARMY HEADQUARTERS

PRINTED NAME GRADE OR TITLE AND TELEPHONE NUMBER

SIGN HERE

DA FORM 2028-2
1 JUL 79

PREVIOUS EDITIONS ARE OBSOLETE

P. S. IF YOUR OUTFIT WANTS TO KNOW ABOUT YOUR RECOMMENDATION MAKE A CARBON COPE OF THIS AND GIVE IT TO YOUR HEADQUARTERS

FILL IN YOUR
UNIT'S ADDRESS

FOLD BACK

DEPARTMENT OF THE ARMY

OFFICIAL BUSINESS

Commander
US Army Communications-Electronics Command
and Fort Monmouth
ATTN: AMSEL-ME-MP
Fort Monmouth, New Jersey 07703-5000

TEAR ALONG PERFORATED LINE

RECOMMENDED CHANGES TO EQUIPMENT TECHNICAL PUBLICATIONS



THEN...JOT DOWN THE DOPE ABOUT IT ON THIS FORM. CAREFULLY TEAR IT OUT, FOLD IT AND DROP IT IN THE MAIL.

SOMETHING WRONG WITH THIS PUBLICATION?

FROM: (PRINT YOUR UNIT'S COMPLETE ADDRESS)

DATE SENT

PUBLICATION NUMBER

TM 11-5895-1227-14-1

PUBLICATION DATE

1 May 1988

PUBLICATION TITLE

Receiver R-2200/GRR-8(V)

BE EXACT PIN-POINT WHERE IT IS

PAGE NO.

PARA-GRAPH

FIGURE NO.

TABLE NO.

IN THIS SPACE TELL WHAT IS WRONG AND WHAT SHOULD BE DONE ABOUT IT:

11-5895-1227-14-1

PRINTED NAME GRADE OR TITLE AND TELEPHONE NUMBER

SIGN HERE

DA FORM 2028-2
1 JUL 78

PREVIOUS EDITIONS ARE OBSOLETE

P.S. IF YOUR OUTFIT WANTS TO KNOW ABOUT YOUR RECOMMENDATION MAKE A CARBON COPE OF THIS AND GIVE IT TO YOUR HEADQUARTERS

FILL IN YOUR
UNIT'S ADDRESS

FOLD BACK

DEPARTMENT OF THE ARMY

OFFICIAL BUSINESS

Commander
US Army Communications-Electronics Command
and Fort Monmouth
ATTN: AMSEL-ME-MP
Fort Monmouth, New Jersey 07703-5000

TEAR ALONG PERFORATED LINE

By Order of the Secretary of the Army:

Official:

CARL E. VUONO
General, United States Army
Chief of Staff

- R. L. DILWORTH
Brigadier General, United States Army
The Adjutant General

DISTRIBUTION:

To be distributed in accordance with DA Form 12-51 literature requirements for AN/PRD-11.

Courtesy of <http://BlackRadios.terryo.org>

Courtesy of <http://BlackRadios.terryo.org>

Courtesy of <http://BlackRadios.terryo.org>