



WATKINS-JOHNSON

Courtesy of <http://BlackRadios.terryo.org>

**INSTRUCTION MANUAL
FOR
TYPE VH-13 TUNING HEAD**

**WATKINS - JOHNSON COMPANY
700 QUINCE ORCHARD ROAD
GAITHERSBURG, MARYLAND 20760**

M/200/3/17/75
2nd Printing

WARNING

This equipment is used with units that employ dangerous voltage levels. Exercise caution when working with these units.

ADDENDA

VH-13

The following changes should be incorporated into the Instruction Manual for the VH-13 Tuning Head.

1. In all cases where the EC-160 Extender Cable is used, change to EC-205.
2. List of Illustrations
 - A. Page iv
 - 1) Change Figure 5-9 from: Type 79656 to: Type 79844-3.
3. Section II - Circuit Description
 - A. Paragraph 2.3.2; Page 2-2
 - 1) Change Type 79656 to: Type 79844-3.
4. Section IV - Maintenance
 - A. Paragraph 4.5.1 Test Equipment Required; Page 4-5
 - 1) Add number (11) as follows: (11) Hetrodyning Extender, CMC Type 735C.
 - B. Paragraph 4.5.3; Page 4-9
 - 1) Change Type 79656 to: Type 79844-3.
 - C. Table 4-2, Typical Element Voltages
 - 1) Change 2N3933 Transistors to: 2N3478.
5. Section V - Replacement Parts List
 - A. Paragraph 5.4.1 VH-13 Tuning Head Main Chassis
 - 1) Change A2 from: 79656 to: 79844-3. (Page 5-4)
 - B. Paragraph 5.4.2 Type 71281 100-180 MHz Tuner (A1)
 - 1) Add CR4 as follows: Diode; Qty. 2; Part Number 1N4003; Mfr. Code 80131. (Page 5-10)
 - 2) Add CR5 as follows: Same as CR4. (Page 5-10)
 - 3) Add R45 as follows: Resistor, Fixed, Composition: 100 k Ω , 5%, 1/4W; Qty. 1; Part Number RCR07G104JS; Mfr. Code 81349. (Page 5-14)

- C. Paragraph 5.4.3 Type 79656 Shaping Amplifier (A2)
- 1) Change this Type Number to: Type 79844-3 100-180 MHz Shaping Amplifier. (Page 5-16)
 - 2) Add an asterisk (*) at R15. (Page 5-17)
 - 3) Change C2 from: 1000 pF, 20%, 1000 V; Part Number DA141-333B; Mfr. Code 71590 to: 1000 pF, 10%, 200 V; Part Number CK05BX102K; Mfr. Code 81349. (Page 5-16)
 - 4) Change R10 from: Same as R9 (10 k Ω ; Part Number RCR07G103JS) to: Resistor, Fixed, Composition: 1 M Ω , 5%, 1/4W; Qty. 4; Part Number RCR07G105JS; Mfr. Code 81349. (Page 5-17)
 - 5) Change R11 from: Resistor, Fixed, Composition: 1 k Ω , 5%, 1/4W; Qty. 1; Part Number RCR07G102JS; Mfr. Code 81349 to: Same as R10 (1 M Ω , Part Number RCR07G105JS). (Page 5-17)
 - 6) Change R18 from: Resistor, Fixed, Composition: 1 M Ω , 5%, 1/4W; Qty. 2; Part Number RCR07G105JS; Mfr. Code 81349 to: Same as R10 (1 M Ω , Part Number RCR07G105JS). (Page 5-17)
 - 7) Change R21 from: Same as R18 to: Same as R10. (Page 5-17)
 - 8) Change R12 from: 100 k Ω ; Qty. 1; Part Number RCR07G104JS to: 100 Ω , Qty. 2; Part Number RCR07G101JS. (Page 5-17)
 - 9) Change R49 from: Resistor, Fixed, Composition: 100 Ω , 5%, 1/4W; Part Number RCR07G101JS; Mfr. Code 81349 to: Same as R12 (100 Ω). (Page 5-18)
 - 10) Change the quantity of R9 from: 2 to: 1. (Page 5-17)
- D. Change all 2N3933 Transistors to: 2N3478.
6. Section VI - Schematic Diagrams
- A. Figure 6-1; Type 71281 100-180 MHz Tuner (A1), Page 6-3
- 1) Add CR4 and CR5 as shown on the following page.

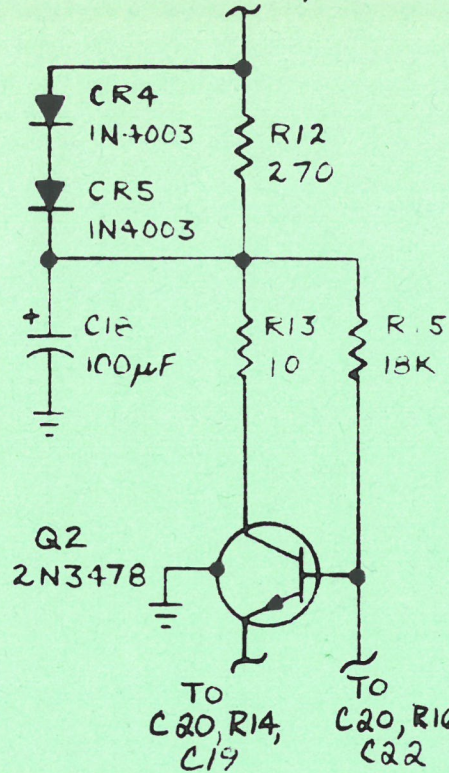

2) Add R45 as shown below:

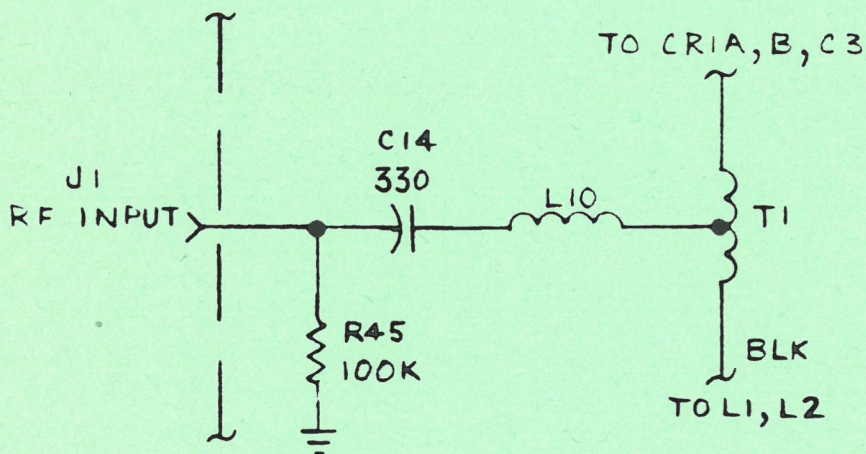

3) At C1, C5, C11, C34, A1C3 and A1C4, add "µF" after the given value.

B. Figure 6-2; Type 79656 Shaping Amplifier (A2); Page 6-5.

- 1) Change the Type Number from: 79656 to: 79844-3.
- 2) Add (note 5) at R15.
- 3) Change R10 from: 10 kΩ to: 1 MΩ.
- 4) Change R11 from: 1 kΩ to: 1 MΩ.
- 5) Change R12 from: 100 kΩ to: 100 Ω.

- C. Figure 6-3; VH-13 Tuning Head Main Chassis; Page 6-7
 - 1) At P4, change the following pin destinations as follows:
 - a) PIN 9 from: Spare to: Marker Code
 - b) PIN 15 from: Spare to: Marker Code
 - NOTE: PIN 3 remains "SPARE".
 - 2) At A2, change the Type Number from: 79656 to: 79844-2.
- D. Change all 2N3933 Transistors to: 2N3478.

23 January 1975
HWO:dwf

7. Section V - Replacement Parts List

- A. Paragraph 5.4.1; VH-13 Tuning Head, Main Chassis; Page 5-4.
 - 1) Change MP1 from: CRANK ASSEMBLY; Qty. 1; Part No. 11755-5; Mfr. Code 14632 to: KNOB/SPINNER; Qty. 1; Part No. 23625-1; Mfr. Code 14632.

TABLE OF CONTENTS

Paragraph		Page
SECTION I GENERAL DESCRIPTION		
1.1	Electrical Description	1-1
1.2	Mechanical Description	1-1
1.3	Equipment Supplied	1-1
1.4	Equipment Required But Not Supplied	1-1
SECTION II CIRCUIT DESCRIPTION		
2.1	General	2-1
2.2	Functional Description	2-1
2.3	Circuit Description	2-1
SECTION III INSTALLATION AND OPERATION		
3.1	Unpacking and Inspection	3-1
3.2	Installation	3-1
3.3	Operation	3-1
3.4	Preparation For Reshipment and Storage	3-1
SECTION IV MAINTENANCE		
4.1	General	4-1
4.2	Plug-In Module	4-1
4.3	Maintenance of Gear Train Assembly	4-1
4.4	Troubleshooting	4-2
4.5	Alignment	4-2
SECTION V REPLACEMENT PARTS LIST		
5.1	Unit Numbering Method	5-1
5.2	Reference Designation Prefix	5-1
5.3	List of Manufacturers	5-1
5.4	Parts List	5-2
SECTION VI SCHEMATIC DIAGRAMS		

LIST OF ILLUSTRATIONS

<u>Illustrations</u>	<u>Page</u>
Figure 1-1	Type VH-13 Tuning Head, Front View 1-0
Figure 2-1	Type VH-13 Tuning Head, Functional Block Diagram 2-0
Figure 2-2	Shaping Amplifier, Simplified Diagram 2-3
Figure 3-1	Type VH-13 Tuning Head, Critical Dimensions 3-2
Figure 4-1	Troubleshooting Diagram 4-3
Figure 4-2	High-Z Detector Diagram 4-5
Figure 4-3	Test Equipment Connections, RF Alignment 4-6
Figure 4-4	Typical 180-MHz RF Response Curve 4-7
Figure 4-5	Typical 100-MHz RF Response Curve 4-7
Figure 4-6	Typical 180-MHz RF Response Curve 4-7
Figure 4-7	Typical 100-MHz RF Response Curve 4-8
Figure 4-8	Typical IF Response Curve (180-MHz RF Input) 4-9
Figure 4-9	Typical IF Response Curve (100-MHz RF Input) 4-9
Figure 4-10	Test Equipment Connections, Shaping Amplifier Alignment 4-10
Figure 4-11	Test Equipment Connections, Tracking and Bandwidth Test 4-12
Figure 5-1	Type VH-13 Tuning Head, Front View, Location of Components 5-5
Figure 5-2	Type VH-13 Tuning Head, Rear View, Location of Components 5-5
Figure 5-3	Type VH-13 Tuning Head, Top View, Location of Components 5-6
Figure 5-4	Type VH-13 Tuning Head, Bottom View, Location of Components 5-7
Figure 5-5	Type 71281 100-180 MHz Tuner (A1), Location of Components 5-9
Figure 5-6	Type 71281 100-180 MHz Tuner (A1), Location of Components 5-11
Figure 5-7	Type 71281 100-180 MHz Tuner (A1), Location of Components 5-13
Figure 5-8	Part 15508 Mixer/IF Amplifier (A1A1), Location of Components 5-15
Figure 5-9	Type 79844-3 Shaping Amplifier (A2), Location of Components 5-18
Figure 5-10	Type 8588 Gear Train Assembly (A3), Exploded View 5-21
Figure 6-1	Type 71281 100-180 MHz Tuner (A1), Schematic Diagram 6-3
Figure 6-2	Type 79656 Shaping Amplifier (A2), Schematic Diagram 6-5
Figure 6-3	Type VH-13 Tuning Head, Main Chassis Schematic Diagram 6-7

LIST OF TABLES

<u>Tables</u>	<u>Page</u>
Table 1-1	Type VH-13 Tuning Head, Specifications v
Table 4-1	Tuning Voltage Versus Frequency Table 4-11
Table 4-2	Typical Transistor Element Voltages 4-13

Table 1-1. Type VH-13 Tuning Head, Specifications

Tuning Range.....	100-180 MHz
Input Impedance.....	50 ohms, nominal
Input VSWR.....	3:1, maximum
Noise Figure.....	7 dB, maximum
Gain x Noise Figure Product	30, ± 3 dB
IF	21.4 -MHz
3rd Order Intercept Point*.....	≥ -10 dBm
Image Rejection.....	75 dB, minimum
IF Rejection	100 dB, minimum
Gain Control Range.....	30 dB, minimum
RF Bandwidth.....	3 MHz, minimum
Local Oscillator Radiation.....	3 μ V, maximum
Local Oscillator Output Level.....	50 mV, minimum, across 50 ohm load
Tuning Voltage:	
Low Band Edge.....	-10 V
High Band Edge	+10 V
Linearity (volts versus frequency)	$\pm 1\%$ of tuning band
Tape Accuracy.....	$\pm 2\%$ of the operating frequency
Dimensions.....	3.12 inches high, 3.0 inches wide, and 14.0 ⁺ inches deep
Weight	3 lbs., approximately

* Referenced to Input (In Band).

+ Measured from back of front panel to rear panel.



Figure 1-1. Type VH-13 Tuning Head, Front View

SECTION I

GENERAL DESCRIPTION

1.1 ELECTRICAL CHARACTERISTICS

1.1.1 The Type VH-13 Tuning Head is designed to operate as plug-in module with the 205 Series Receivers. The VH-13 tunes the frequency range of 100 to 180 MHz and provides a 21.4-MHz IF output for the receiver. The tuning head can be manually or electrically tuned depending upon the operating mode of the 205 Series Receivers. A front panel tuning knob and tape dial are provided for use in the manual tuning mode and a tuning voltage range of +10.3 to -10.3 volts from the receiver will tune the unit from the low band limit to the high band limit.

1.1.2 The tuning head consists of a voltage tuned RF amplifier and local oscillator, mixer, IF amplifier, and circuits to shape the tuning voltage input from the receiver to provide a linear volts versus frequency tuning curve for the unit. In addition to the 21.4-MHz IF output, buffered local oscillator output and a five wire code are provided for operation of the accessory DRO-308 Counter, DRX-308 Digital Readout Extender, and VM-105 Marker Accessory. Additional jumper wires in the VH-13 select the appropriate IF bandwidths for both the PAN and SECTOR operating modes of the 205 Receiver.

1.2 MECHANICAL CHARACTERISTICS

1.2.1 The VH-13 Tuner is designed as a plug-in modular unit for the 205 Series Receivers. All electrical connections to the unit are provided by plug-in connectors on the VH-13 rear panel. Figure 5-2 illustrates the rear panel connectors. Front panel controls consist of the manual tuning knob and tape dial, and mechanical lock. The VH-13 front panel is illustrated in Figure 5-1.

1.2.2 The VH-13 Tuner frame is constructed of aluminum with a 3.0 x 3.125 inch aluminum front panel. The front panel is finished with gray enamel and is overlaid with a black etched bezel. The 100 to 180 MHz RF tuner subassembly (A1) is constructed of silver-plated brass which has been gold-flashed to prevent tarnishing. Shaping amplifier (A2) is constructed on a plug-in etched circuit board. The tape dial and gear train assembly (A3) are constructed as a unit and mount on the RF tuner subassembly and the VH-13 front panel.

1.3 EQUIPMENT SUPPLIED

This equipment consists of the Type VH-13 Tuning Head only. The dimensions and weight are given in Table 1-1.

1.4 EQUIPMENT REQUIRED BUT NOT SUPPLIED

The VH-13 is designed to operate with the 205 Series Receivers. It is not capable of independent operation. In addition, to perform any maintenance on the VH-13 while it is operating, a Type EC-205 Extender Cable unit is required.

Figure 2-1

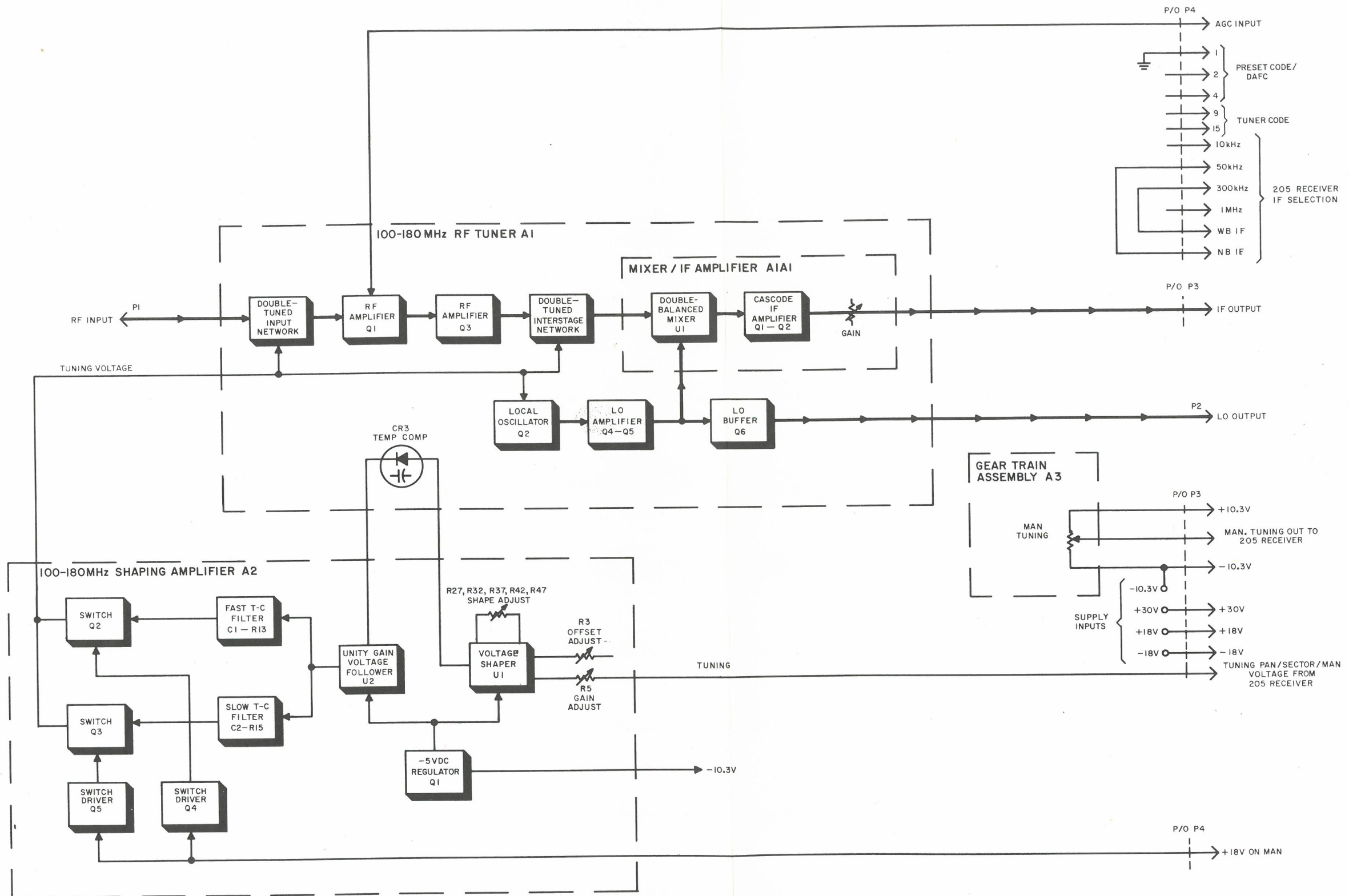

Figure 2-1. Type VH-13 Tuning Head, Functional Block Diagram

SECTION II

CIRCUIT DESCRIPTION

2.1 GENERAL

Operation of the various circuits in the VH-13 Tuner is described in the following paragraphs using the functional block diagram, Figure 2-1, and the schematic diagrams in Section VI of this manual. The unit numbering method is used for electrical components. This means that parts on subassemblies carry a prefix before the class letter and number of the item (such as A1Q1 and A1R6). These subassembly prefixes are omitted on illustrations and in the text, except in those cases where confusion might result from their omission.

2.2 FUNCTIONAL DESCRIPTION

2.2.1 Figure 2-1 illustrates the functional interconnections between the various subassemblies of the VH-13. Input signals are applied to a double-tuned input network in the 100 to 180 MHz tuner subassembly (A1). This provides input selectivity and impedance matching for best combination noise figure and V. S. W. R. for the VH-13. A dual insulated gate field effect transistor is used as RF amplifier A1Q1 for good intermodulation characteristics and ease of automatic gain control of the stage. The output of A1Q1 drives second RF amplifier A1Q3. Both RF amplifier stages form a modified cascode circuit. A second double-tuned network is used at the output of A1Q3. The output signals from the double-tuned interstage network drive a solid state double-balanced mixer in mixer/IF subassembly A1A1. Transistor A1Q2 functions as a voltage-tuned local oscillator operating 21.4-MHz above the incoming RF signal. Its output drives LO amplifier A1Q4-Q5 which in turn drives the double-balanced mixer A1A1U1 and LO output buffer A1Q6. The output from A1Q6 is used to drive an accessory frequency counter to provide digital readout of the tuned frequency of the 205 Series Receivers. Output signals from the double-balanced mixer are amplified by a 21.4-MHz cascode amplifier formed by A1A1Q1-Q2. The 21.4-MHz IF output from the RF tuner subassembly is connected to jack A1 of plug P3 on the VH-13 rear panel.

2.2.2 Shaping amplifier A2 provides the tuning voltage for the varactor diodes in the double-tuned networks and local oscillator in subassembly A1. It consists of circuits which receive a linear ramp and summed manual tuning voltage, or manual tuning voltage from the 205 Receiver, depending upon the operating mode of the receiver, and shapes the voltage to provide a linear volts versus frequency tuning characteristic for the VH-13. Operational amplifier A2U1 shapes the tuning voltage from the receiver. Its output voltage is applied through temperature compensation diode A1CR3 to another operational amplifier, A2U2. Unity gain amplifier, A2U2, drives two R-C filters which are used to remove noise from the voltage output when the sweeping modes of tuning are used. Transistor stages A2Q2-Q5 are switching circuits to select the tuning voltage from the appropriate filter. Transistor A2Q1 functions as a voltage regulator which supplies a -5 Vdc reference voltage for A2U1 and A2U2.

2.3 CIRCUIT DESCRIPTION

2.3.1 Type 71281 100-180 MHz Tuner. - Figure 6-2 is the schematic diagram for this subassembly; its reference designation prefix is A1. Input signals to the module are applied to jack A1J1. The RF signals are then coupled through C14 and L10 to input transformer T1. The transformer tap sets the proper loading to the input of the double-tuned network. Transformer T1, varactor diode CR1A, and capacitor C3 form one half of the input double-tuned circuit. The remaining half of the input circuit is formed by L2, CR1B, and C6. Inductor L1 provides inductive coupling between the two sections of the circuit. The varactor diodes used to voltage tune this module are matched devices, selected to exhibit similar voltage versus capacity characteristics. The varactor diodes are semiconductor devices whose capacitance is inversely related to the reverse bias applied to them. Thus, increasing the reverse bias across the diodes decreases their capacitance. Capacitor C7 couples the RF signals from the input double-tuned circuit to gate #1 of Q1. Bias on gate #1 (signal gate) of Q1 is taken from the junction of voltage divider resistors R3 and R4 and is approximately 1.3 volts. Gate #2 is used for gain control of the stage. The biasing voltage on gate #2 is taken from the junction of R5 and R8. AGC voltage is applied to the gate through R7 and R8 and is nominally 0 volts and swings to a maximum of approximately -6.2 volts. Resistors R5, R8, and diode CR2 form the biasing circuit on gate #2 and set the bias at approximately +4 volts with the AGC voltage at 0 volt. When the AGC voltage goes sufficiently negative to reverse bias CR2, the diode is effectively removed from the circuit which permits the junction of R5 and R8 (gate bias) to follow the AGC voltage. The output of Q1, developed across L3, is coupled to the source of Q3, a junction field effect transistor. Transistor Q3

functions as a grounded gate amplifier. Its output is coupled to the interstage, double-tuned network. The interstage double-tuned network is functionally identical to the input network, except that it is over-coupled to form a single damp response with the input tank circuit.

2.3.1.1 Output from the tap of transformer T2 is applied to the double-balanced mixer on the mixer/IF amplifier board A1. The output from double-balanced mixer A1U1 is applied to IF amplifier A1A1Q1-Q2. These transistors form a cascode amplifier tuned to 21.4 MHz by T1 and C5. Negative feedback across A1A1Q1, coupled through R2 and C2, and its un-bypassed emitter resistor increases the dynamic range of the cascode stage. The IF output is taken from the center-tap of transformer T1. Potentiometer R7 provides a means of adjusting the output level.

2.3.1.2 Transistor Q2 functions as a modified Colpitts, voltage tuned oscillator. Emitter to base regeneration to sustain oscillation is developed by voltage divider capacitors C19 and C20. The oscillator tank circuit consists of L4, C24, C26, and varactor diode CR1E. Capacitor C22 functions as a dc blocking capacitor to isolate the transistor base voltage from L4 and CR1E and couples the tank circuit to the transistor. Capacitor C24 is a padding capacitor used to achieve proper tracking between the RF tank circuit and the oscillator tank circuit. The output voltage from the oscillator is lightly coupled to the base of Q4 through C29. Transistor Q4 is an emitter follower, and its output is direct coupled to the base of common emitter amplifier Q5. Local oscillator voltage for double-balanced mixer A1U1 is taken from matching transformer T3 and coupled through C38. In addition, some of the LO signal is applied to Q6 through C40. Transistor Q6 functions as the buffer amplifier for the LO output. Its output is taken from the tap of transformer T4 and coupled through C46. Diode CR3 is used as a temperature compensating diode. Its function will be explained in a later paragraph.

2.3.2 Type 79844-3 100-180 MHz Shaping Amplifier. - Figure 6-2 is the schematic diagram for the shaping amplifier; its reference designation prefix is A2. This circuit is constructed on a plug-in etched circuit board. It receives a +10.3 to -10.3 volt tuning voltage from the 205 Receiver and provides a shaped +2 to +25 volt output which complements the voltage versus capacitance characteristics of the varactor diodes used in the 100-180 MHz tuner subassembly. The diode characteristics are such that for a given reverse bias change, a greater change in capacity occurs in the maximum capacity region than at the minimum capacity region. The shaped voltage output from this subassembly provides linear tuning over the range of 100 to 180 MHz. As shown in the functional block diagram, Figure 2-1, the circuit consists of voltage shaper U1, unity gain voltage follower U2, R-C filters, filter switching transistors Q2 and Q3, switch drivers Q4 and Q5, and -5 Vdc regulator transistor Q1.

2.3.2.1 The voltage shaping circuit consists of integrated circuit operational amplifier U1 and its associated feedback network. Figure 2-2 simplifies the voltage shaper circuit by showing only a portion of its feedback network. Operational amplifier U1 amplifies the difference between its two inputs. The non-inverting input (pin 3) of the IC is returned to ground through R8, which balances current flow through both inputs of the amplifier. The tuning voltage is applied to the inverting input (pin 2) through R5 and R6. Also connected to the inverting input is an OFFSET ADJUST voltage applied through R3 and R4, negative feedback voltage applied through R7, and negative feedback voltage applied through CR7, CR5, and R25. The voltage gain of the operational amplifier is determined by the ratio of total input resistance to total feedback resistance. The network consisting of R25 through R28 and CR6 is a biasing network for "break" diode CR7. To illustrate the circuit operation, assume that the low band edge tuning voltage (+10.3V) is applied to the shaper. At this point, the output voltage from U1 is approximately +2 volts. The first break point for the output voltage curve is determined by the setting of R27 which applies a positive voltage to the cathode of CR6. The voltage drop across R25 is such that the voltage applied to the anodes of CR7 and CR5 is sufficiently positive to forward bias them. However, CR6 is reverse biased due to the voltage applied to it through R27. Now the feedback across U1 consists of the voltage developed across R7 and the voltage across CR7, CR5, and R24. When the input tuning voltage goes negative, the output voltage of U1 swings positive from the initial +2 volt level. The output of U1 changes linearly with respect to its input until it reaches the point where CR6 becomes forward biased. When CR6 begins to conduct, the voltage at the junction of CR5, CR6, and CR7 is clamped by current flow through CR6. At this point CR7 becomes reverse biased with any further positive increase at the output of U1. When CR7 becomes reverse biased, the negative feedback loop consisting of CR7, CR5, and R24 is broken, increasing the gain of U1. Diodes CR5 through CR19 and associated circuitry, as shown in the schematic diagram, are all components of the gain modifying (feedback) network. When the output voltage of U1 reaches the level set by R32 the next gain curve "break" takes place and the feedback across U1 is further reduced, increasing the voltage gain of U1 and further changing the slope of the output voltage curve. The "break" point potentiometers are all adjusted to provide linear tuning over the range of 100 to 180 MHz. Diode CR1 is included across the "permanent" feedback resistor, R7, to protect the varactor diodes in the 100-180 MHz tuner

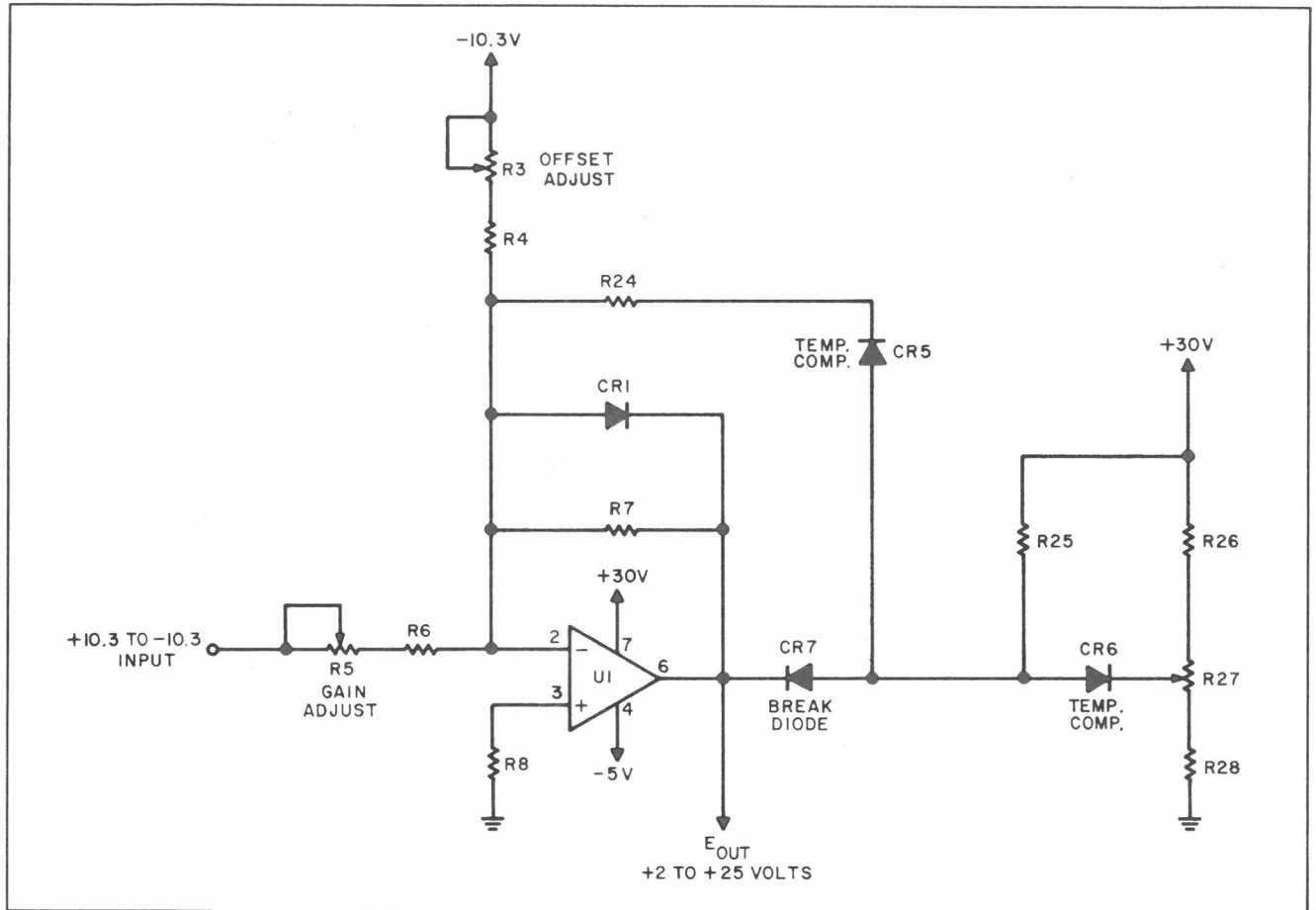

Figure 2-2. Shaping Amplifier, Simplified Diagram

subassembly. Should the output voltage from U1 ever go negative, which would forward bias the varactor diodes and possibly damage them, diode CR1 conducts. With CR1 conducting a direct negative feedback path is provided which will hold the output voltage from U1 around zero volts.

2.3.2.2 The shaped output voltage from U1 is applied to operational amplifier U2 through varactor diode CR3 in the 100-180 MHz tuner subassembly. Diode CR3 is forward biased by the tuning voltage. Variations in the contact potential of the tuning diodes caused by temperature changes are cancelled by the drop across A1CR3 whose contact potential varies a similar amount. Operational amplifier U2 is used as a unity gain voltage follower to provide isolation from the voltage shaper. The shaped voltage coupled through A1CR3 is applied to the non-inverting input (pin 3) of the amplifier. Negative feedback to the inverting input (pin 2), and positive feedback taken from the junction of R11 and R12 and coupled through R10, set the stage gain at one. Supply voltages for the operational amplifiers are provided by the +30 Vdc applied to pin 21 of the shaping amplifier board and the -5 Vdc supplied by Q1. Transistor Q1 functions as a series regulator. Bias for the base is taken from the junction of R1 and R2.

2.3.2.3 The output voltage from U2 is applied through R-C filters to FET switches Q2 and Q3. The filters remove noise from the tuning voltage output. Resistor R13 and C1 form the slow time constant filter used in the MAN mode of operation. A faster time constant filter formed by R15 and C2 is used when the 205 Series Receivers are operated in the PAN or SECTOR sweeping modes. Transistors Q4 and Q5 provide the switching voltage for the FETs. Positive 18 volts is applied to pin 2 of the shaping amplifier board in the MAN mode. In this mode, the base bias on Q5 is not sufficiently negative to cause the transistor to conduct. With Q5 off, the base voltage on Q4 goes sufficiently negative to cause it to conduct due to the voltage drop across R20, R19, and R21. The collector voltage of Q5, the non-conducting transistor, is approximately -8 Vdc which causes CR3 to conduct clamping the voltage at the gate of Q3 low and turning the transistor off. However, the positive voltage at the collector of Q4,

the conducting transistor, reverse biases CR2 allowing the gate voltage on Q2 to approach the source voltage and Q2 conducts. With Q2 conducting, the output voltage from the unity gain voltage follower is through the slow R-C filter and transistor Q2 to output pin 3. When the 205 Receiver is switched to the PAN or SECTOR modes, pin 2 of the shaping amplifier board is clamped at -2 Vdc. The low input voltage on pin 2 provides a return path from the +30 volt supply through R22, R23, and VR1. Due to the current flow through it, the voltage across R22 swings negative turning Q5 on. With Q5 on, the voltage at the base of Q4 goes positive turning it off. Now -8 volts is applied to CR2 clamping the gate of Q2 low and turning it off. The positive voltage at the collector of Q5 reverse biases CR3 allowing the gate of Q3 to approach the source voltage and Q3 conducts. With Q3 conducting, the output voltage from the shaper board is coupled through the fast R-C filter.

2.3.3 Type VH-13 Tuning Head. - Figure 6-3 is the schematic diagram for the main chassis of the VH-13. This drawing illustrates the overall connections between the subassemblies of the tuner. Module A3 is a Type 8588 Gear Train. It consists of the manual tuning precision potentiometer and the necessary gear train and tape frequency dial to drive it. An exploded view of the gear train is included in Section V of this manual. Multipin connector P3 located on the VH-13 rear panel supplies IF output, tuning voltage inputs and outputs, and power supply inputs. The manual tuning voltage output is linear, -10.3 volts at the low band limit and +10.3 volts at the high band limit. It is inverted in the 205 Receiver and returned to the VH-13 in the MAN mode. In the PAN or SECTOR modes the MAN tuning voltage is inverted and summed with the ramp voltage in the receiver and then applied to the VH-13. Rear panel plugs P1 and P2 provide RF input and local oscillator output connections respectively. Control inputs other than tuning voltage are provided through rear-panel plug P4. Pins 1, 2, 4, 9, and 15 provide a code output which is used by the DRO-308 Frequency Counter, the DRX-308 Frequency Extender, and the VM-105 Marker Accessory units. Pins 5, 6, 7, 8, 14, and 13 provide connections which select the proper bandwidth IF amplifiers in the 205 Receiver for the PAN and SECTOR modes. Pin 12 supplies the mode control voltage for shaping amplifier A2 and pin 10 provides the AGC connection to the 100-180 MHz tuner subassembly.

SECTION III

INSTALLATION AND OPERATION

3.1 UNPACKING AND INSPECTION

3.1.1 Examine the shipping carton for damage before the equipment is unpacked. If the carton has been damaged try to have the carrier's agent present when the equipment is unpacked. If not, retain the shipping cartons and padding material for the carrier's inspection if damage to the equipment is evident after it has been unpacked.

3.1.2 See that the equipment is complete as listed on the packing slip. Contact Watkins-Johnson Company, CEI Division, or your Watkins-Johnson representative with details of any shortage.

3.1.3 The unit was thoroughly inspected and factory adjusted for optimum performance prior to shipment. It is, therefore, ready for use upon receipt. After uncrating and checking contents against the packing slip, visually inspect all exterior surfaces for dents and scratches. Inspect the internal components for apparent damage. Check the internal cables for loose connections and the printed wiring board which may have been loosened from its receptacle.

3.2 INSTALLATION

The VH-13 Tuning Head is a plug-in unit designed to operate exclusively with the 205 Series Receivers. All operating voltages and RF signals are provided by rear-panel connectors on the tuner, which mate with the 205 Series Receivers.

3.3 OPERATION

Operation of the VH-13 Tuning Head is controlled entirely by the associated 205 Receiver with the exception of the front-panel manual tuning knob.

3.4 PREPARATION FOR RESHIPMENT AND STORAGE

3.4.1 If the unit must be prepared for reshipment, the packaging methods should follow the pattern established in the original shipment. If retained, the original materials can be reused to a large extent or will at a minimum provide guidance for the repackaging effort.

3.4.2 If time permits, contract packing and packaging firms can be found in many cities. Based on an examination of the equipment and the proposed method of shipment, these firms can usually perform a reliable repackaging service.

3.4.3 As a minimum, cover the painted surface of the unit with wrapping paper. Pack the unit securely in a strong corrugated container (350 lb/sq inch bursting test) with 2-inch rubberized hair pads placed along all surfaces of the equipment. If rubberized hair is not available, use a 6-inch layer of excelsior. If neither of these filler materials are available, use crumpled paper, rags, or any other available materials to provide as much cushioning as possible.

3.4.4 Conditions during storage and shipment should normally be limited as follows:

- (1) Maximum humidity: 95% (no condensation).
- (2) Temperature range: -30°C to +85°C.

Figure 3-1

VH-13

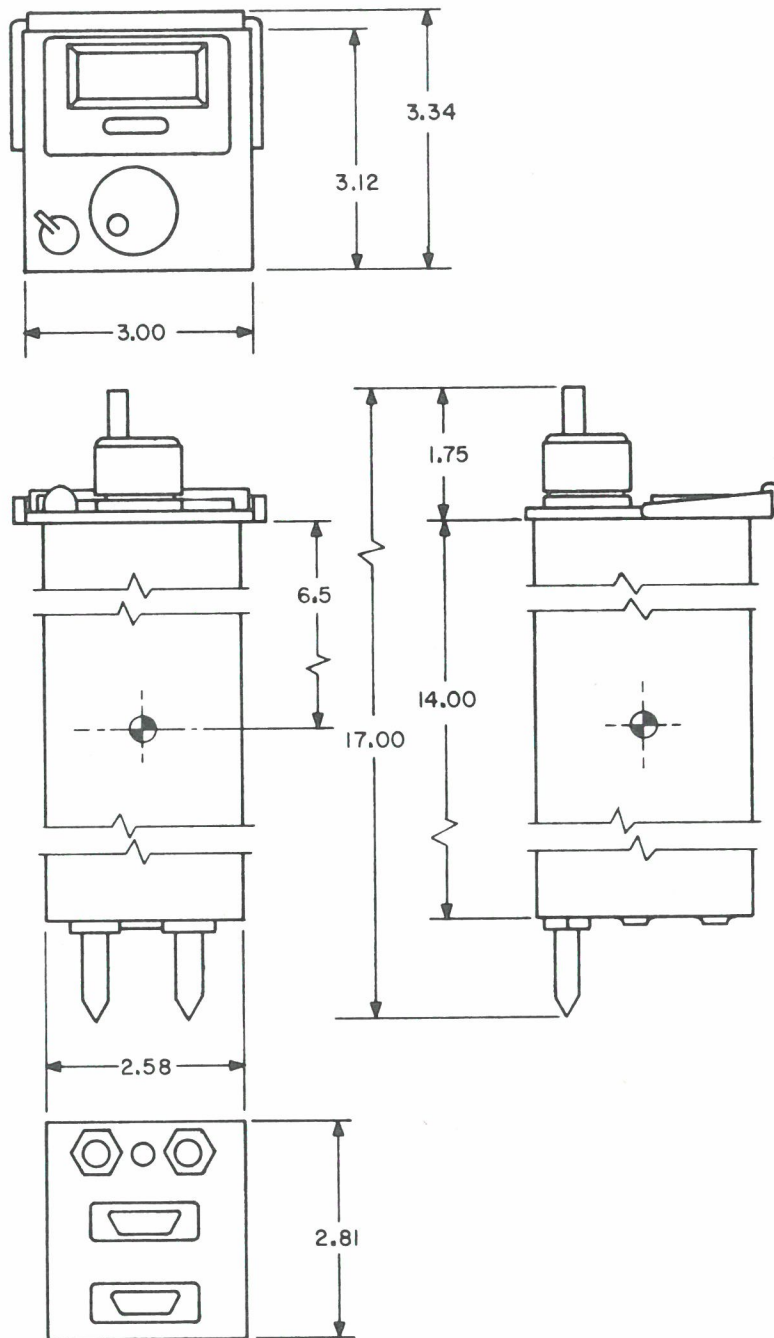

Figure 3-1. Type VH-13 Tuning Head, Critical Dimensions

SECTION IV

MAINTENANCE

4.1 GENERAL

The VH-13 Tuning Head has been designed to operate for extended periods of time with only routine maintenance. The unit requires no special care and normally requires only cleaning and occasional gear train lubrication. Alignment of the tuner requires a thorough understanding of the function of each subassembly and should be attempted only after repairs which affect the alignment and then only by experienced personnel in a well-equipped shop.

4.2 PLUG-IN MODULE

The printed circuit shaping amplifier board can be removed by unsnapping the hinge lock located on the side of the tuner and carefully swinging the board up where it can be unplugged. Careful removal and installation of the shaper board will not disturb the VH-13 alignment.

4.3 MAINTENANCE OF GEAR TRAIN ASSEMBLY

Figure 5-10 is an exploded view of the gear train assembly. The gear train assembly requires little maintenance except for the occasional application of a few drops of light oil to the shaft bearings and removal of any dust or dirt that may accumulate.

4.3.1 Dial Lamp Replacement. - To replace a burned out dial lamp, proceed as follows:

- (1) Remove the two screws that hold the dial escutcheon. Remove the escutcheon (refer to Figure 5-10).
- (2) Remove the two screws that hold the light bar to the gear train.
- (3) Gently pull the light bar and printed circuit light board away from the gear train. It may be necessary to remove some lacing cord from the wires that feed the lamps.
- (4) Remove the two screws that hold the light board to the light bar.
- (5) Unsolder the burned out lamp and replace it with a new lamp. It is advisable to replace both lamps if parts are available because if one lamp burns out, it is likely that the other lamp is nearing the end of its life.
- (6) Reassemble the unit by reversing steps (1) through (4).

4.3.2 Alignment of Tape Dial. - A calibrated steel tape is used as the tuning dial. It is geared to the assembly in such a manner that it is unlikely it will ever get out of position. However, to check the alignment or to mechanically realign the tape, follow the steps given below:

- (1) Turn the tuning knob counterclockwise until the tape dial stops moving.
- (2) The mark to the left of the arrow should line up with the dial pointer. If it does not, proceed with the next step.
- (3) Loosen the setscrew on gear no. 27 (Figure 5-10).
- (4) Remove the dial escutcheon as described in paragraph 4.3.1, step (3), if necessary.
- (5) By hand, move the tape dial and gear no. 27 independent of the rest of the gear train, to align the reference mark with the pointer.
- (6) Tighten the setscrew on gear no. 27 and replace the dial escutcheon.
- (7) Tune from one end of the dial to the other to determine if binding occurs in the gear train. If some binding is present, loosen the setscrew on gear no. 27 and slightly readjust its vertical position.

4.3.3 Removal and Disassembly of Gear Train and Tape Dial. - The gear train and tape dial assembly may be removed from the tuner by performing the steps listed below. Once removed, the gear train may be disassembled using Figure 5-10 as a guide.

- (1) Remove the main tuning knob.
- (2) Remove the two screws that hold the dial escutcheon. Remove the escutcheon.
- (3) Remove the two screws that hold the light board to the light bar.
- (4) Unsolder the wire providing input voltage to the lights.
- (5) Unsolder the wires connected to the tuning potentiometer. Tag each of the leads.
- (6) Turn the tuner assembly upside down and loosen the two screws which mount the RF tuner subassembly to the gear train.
- (7) Remove the three screws from both sides of the tuner wrap-around which hold the gear train. Gently pull the gear train assembly from the tuner.
- (8) Further disassembly should not be required. However, the front-panel may be removed from the gear train by removing the tuner mechanical lock, the screw in the lower right corner of the front panel, and the two screws underneath the panel bezel.
- (9) To reassemble, reverse the above procedure.

4.4 TROUBLESHOOTING

Troubleshooting or repairs of the VH-13 Tuning Head while the unit is operating requires the use of an EC-205 Extender Cable. After interconnecting the VH-13 and 205 Series Receiver using the EC-205, initial investigation should be directed toward localizing the malfunction to a specific subassembly. A troubleshooting diagram is provided in Figure 4-1 which will aid the technician in troubleshooting efforts. A thorough understanding of the circuit operations as detailed in Section II of this manual will enable the technician to repair the faulty subassembly once it is isolated. In addition, typical transistor element voltages are provided in Table 4-2.

4.5 ALIGNMENT

The alignment procedures provided in this subsection are satisfactory for alignment of the VH-13 after a major component replacement. Varactor diodes in the 100-180 MHz tuner subassembly are matched components. If failure of a diode occurs, its replacement may not match the characteristics of the remaining units. To obtain satisfactory performance from the VH-13 all varactor diodes may have to be replaced with a matched set. Alignment of the VH-13 should be attempted only by trained and experienced technicians thoroughly familiar with the unit. If the alignment procedures detailed in the following paragraphs do not provide satisfactory performance from the VH-13, a factory alignment is required.

CAUTION

Exercise care when performing these procedures not to short any components when power is on. Failure to observe this precaution may result in the destruction of one or more transistors.

4.5.1 Test Equipment Required. - The following test instruments, or their equivalents, are required to align the VH-13 Tuning Head

- (1) Oscilloscope, Tektronix Type 503
- (2) Sweeping Signal Generator, Telonic Type SM2000 with SH-1 Plug-in Head and internal 1, 10, and 50 MHz marker oscillators.
- (3) Regulated Variable Power Supply 0-30 Vdc, Hewlett Packard-Harrison Type 6206B.



Figure 4-1. Troubleshooting Diagram

- (4) 50 Ohm Detector, Telonic XD-3A.
- (5) High Z Detector, Refer to Figure 4-2 (two required).

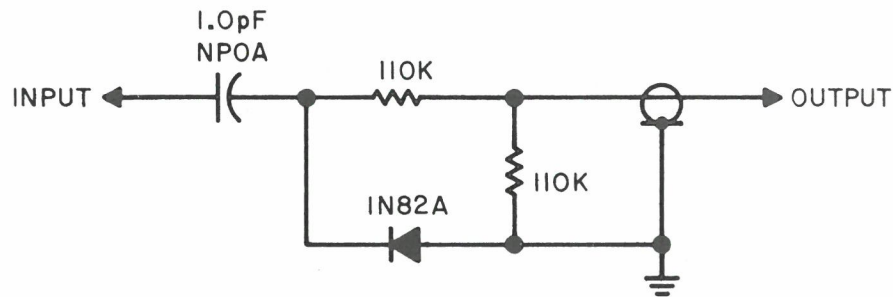

Figure 4-2. High Z Detector Diagram

- (6) Frequency Counter, Computer Measurements Company Type CMC-738A.
- (7) Heterodyning Extender, Computer Measurements Company Type CMC-735C.
- (8) Signal Generator, Hewlett Packard Type HP-608E.
- (9) Digital Voltmeter, Dana Type 5500/112.
- (10) Extender Cable, CEI Type EC-205.
- (11) Assorted Cables, Connectors, and Alignment Tools.

4.5.2 Type 71281 100-180 MHz Tuner Alignment. - Proceed as follows:

- (1) Remove shaping amplifier A2 by unlocking the hinge lock on the side of the VH-13, rotating the hinged receptacle upward and then carefully pulling the board from its receptacle. Place the receiver in the AM MAN reception mode.
- (2) Connect the VH-13 to the 205 Receiver using the EC-205 Extender Cable. Remove the bottom cover of subassembly A1. Set the receiver VIDEO GAIN MAX CW.
- (3) Connect the test equipment as shown in Figure 4-3.

CAUTION

Before energizing the equipment, make sure that the regulated power supply voltage will not exceed +2 to +28 Vdc. Failure to observe this precaution may result in the destruction of matched varactor diodes in the tuner sub-assembly.

- (4) Energize the equipment. Set the regulated power supply voltage to approximately +2 Vdc, and adjust the sweep generator and oscilloscope controls to display a 100 MHz response curve. Use the HP-608E and frequency counter to provide an accurate 100-MHz marker.
- (5) Adjust the regulated power supply output voltage (tuning voltage) to center the response about the 100-MHz marker. Note the digital voltmeter reading and use this tuning voltage in succeeding steps which require tuning to 100-MHz.

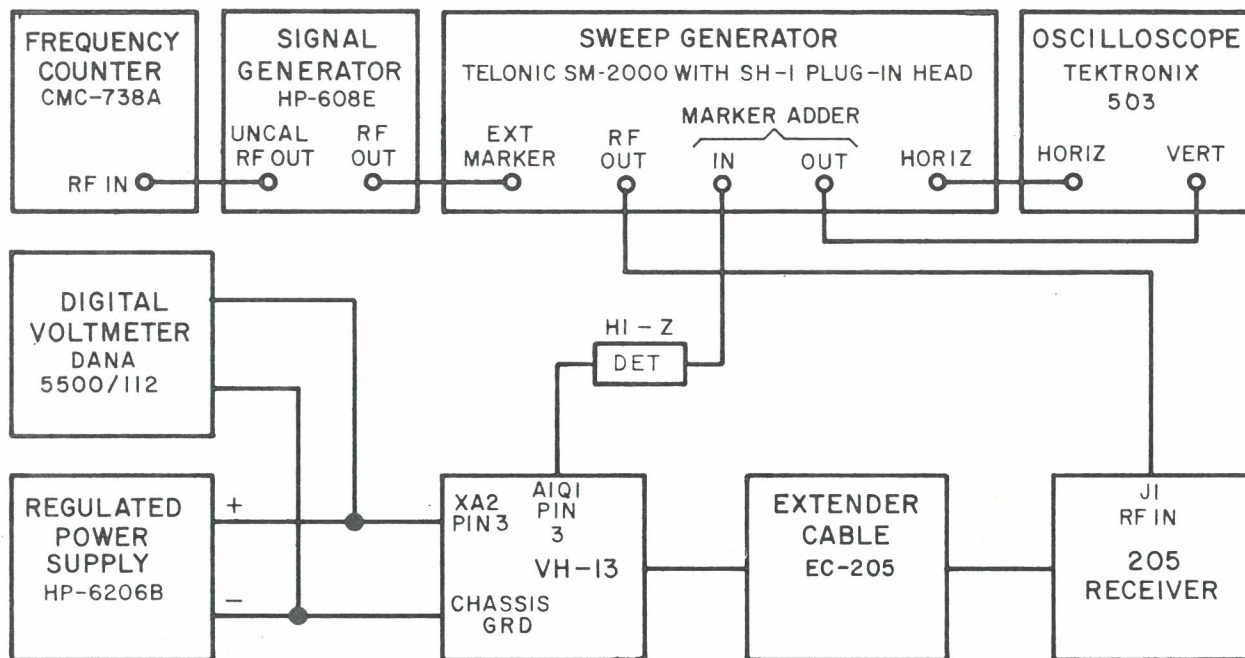

Figure 4-3. Test Equipment Connections, RF Alignment

- (6) Adjust the tuning voltage to +25 Vdc and set the sweep generator and oscilloscope controls to display a 180-MHz response curve. Use the signal generator to provide an accurate 180-MHz marker.
- (7) Set A1C6 to minimum capacity to compensate for the shunt capacity of the high-Z detector. Adjust A1C3 for maximum response centered about the 180-MHz marker. If necessary, adjust the coil spacing of A1L2 by applying Q-dope solvent and carefully spacing the turns. Exercise caution to avoid damage to the inductor core material. Alternate adjustment of A1C3 and A1L2 should provide a response curve similar to the one illustrated in Figure 4-4.

NOTE

Excessive shunt capacity across A1L2 will shift the 100 MHz tuning voltage out of the desired range, approximately +2.0 Vdc.

- (8) Set the tuning voltage to the level corresponding to 100-MHz. Adjust the sweep generator, oscilloscope, and signal generator to display a 100 MHz response and marker.
- (9) Adjust A1T1 for maximum response centered about the 100-MHz marker, then adjust A1L1 for transitional coupling and a 3-MHz bandwidth at the 3 dB points on the response curve. Figure 4-5 illustrates a typical response curve. Repeat steps (5) through (9) until no further adjustment is necessary. Leave the high-Z detector in the circuit.
- (10) Connect the marker adder input of the sweep generator through the second high-Z detector to the center-tap of A1T2 at feedthrough point A1E1.
- (11) Set the tuning voltage to +25 Vdc and adjust the sweep generator, oscilloscope, and marker generator controls to display a response curve with an accurate 180-MHz marker.
- (12) Adjust A1C28 and A1C35 for an overcoupled response centered about the 180-MHz marker. A typical response is illustrated in Figure 4-6.

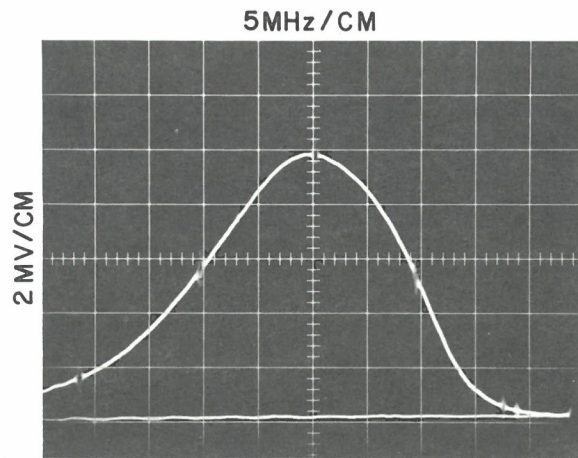

Figure 4-4. Typical 180 MHz RF Response Curve

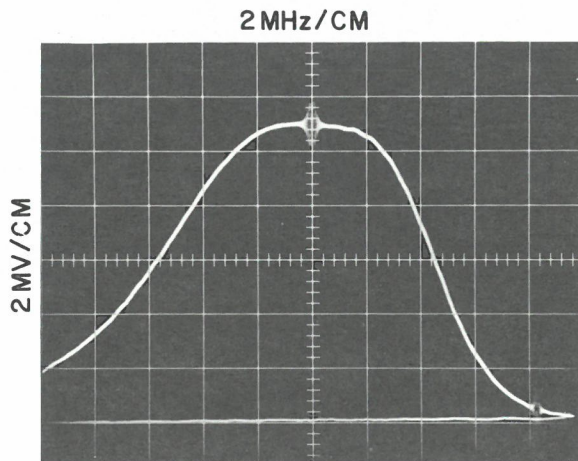

Figure 4-5. Typical 100-MHz RF Response Curve

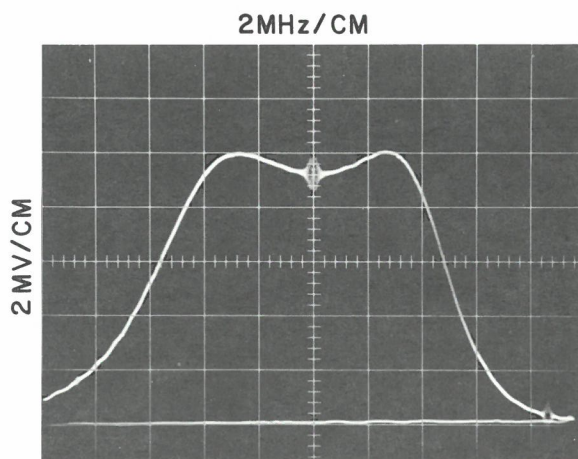

Figure 4-6. Typical 180-MHz RF Response Curve

- (13) Set the tuning voltage to the 100-MHz level and adjust the sweep generator, oscilloscope, and marker generator controls to display a 100-MHz response with an accurate 100-MHz marker.
- (14) Use Q-Dope Thinner first, then carefully adjust A1L6 and A1L8 for an overcoupled response centered about the 100-MHz marker.
- (15) Adjust A1L7 for the desired coupling to produce a 3-MHz bandwidth at the 3-dB points on the response curve. Figure 4-7 illustrates a typical response curve. Remove the high-Z detector from A1Q1 pin 3 and adjust A1C6 to restore the symmetrical response about the 100-MHz marker. Repeat steps (11) through (15) until no further adjustment is necessary. Remove the second high-Z detector.

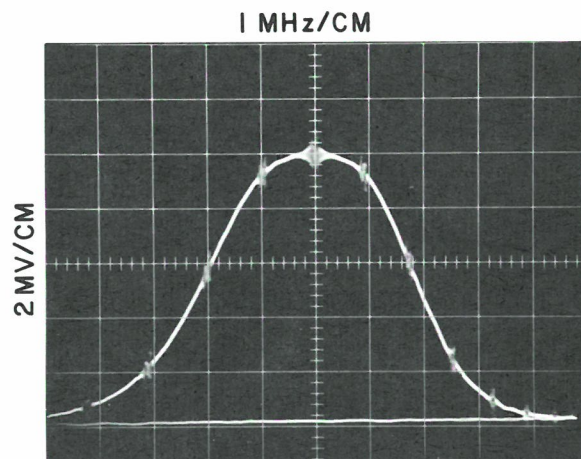

Figure 4-7. Typical 100-MHz RF Response Curve

- (16) Connect the frequency counter to A1J2. Set the tuning voltage to +25 Vdc and adjust A1C26 for a frequency readout of 201.76 MHz (180.36 + 21.4 MHz).
- (17) Set the tuning voltage to the 100-MHz level and adjust A1L4 for a frequency readout of 121.400 MHz (100 MHz + 21.4 MHz).
- (18) Repeat steps (16) and (17) with the tuner assembly cover on making necessary adjustments until the local oscillator limits are correctly set.
- (19) Connect the test equipment as in Figure 4-3 except use the XD-3A detector and connect the detector to A1J3.
- (20) Set the tuning voltage to +25 Vdc and adjust the sweep generator, oscilloscope and marker generator controls to provide a 180-MHz response with a 180-MHz marker. Adjust A1A1C5 to peak the response about the 180-MHz marker. Figure 4-8 illustrates a typical response.
- (21) Set the tuning voltage to the 100-MHz level. Adjust the sweep generator, oscilloscope, and marker generator controls to display the 100-MHz response with an accurate 100-MHz marker. A typical response is illustrated in Figure 4-9.
- (22) Simultaneously adjust the sweep generator and tuning voltage over the entire 100 to 180 MHz range of the VH-13 noting the overall gain variation which should be no greater than 4 dB.
- (23) Adjust A1R7 for a gain of 24 dB at a frequency which will allow the gain variation to be average over the bandpass. Repeat step (20) to correct any response tilt caused by the gain adjustment. Apply Q-Dope to the adjustable coils and replace the A1 subassembly bottom cover.

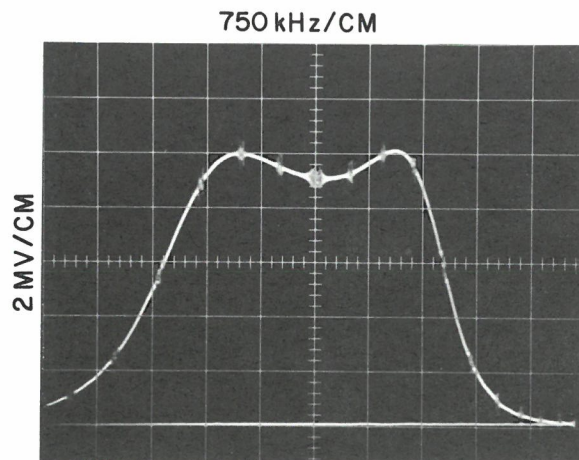

Figure 4-8. Typical IF Response Curve (180 MHz RF Input)

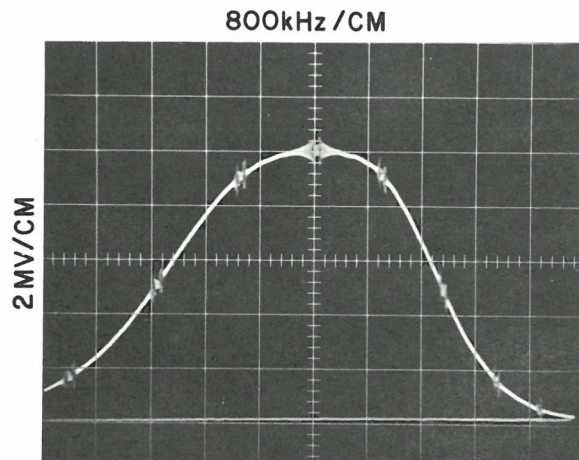

Figure 4-9. Typical IF Response Curve (100 MHz RF Input)

- (24) Check the LO-RF tracking and bandpass response by simultaneously adjusting the sweep generator and tuning voltage over the entire 100-180 MHz range with the cover on.
- (25) If excessive tilt is noticed in the bandpass, greater than 3 dB, compensation can be made by adjusting A1L6 and A1L8 at the low end and A1C28 and A1C35 at the high end until desirable results are obtained.

4.5.3 Type 79844-3 100-180 MHz Shaping Amplifier Alignment. - The shaping amplifier receives a +10.3 Vdc to -10.3 Vdc tuning voltage from the 205 Receiver and provides a +2 Vdc to +25 Vdc voltage output that is shaped to complement the characteristics of the varactor tuning diodes in subassembly A1. Accurate alignment of the shaping amplifier will provide tuning linearity greater than the 1% specification. This alignment procedure is complex and should only be attempted when absolutely necessary. Proceed as follows:

- (1) Connect the test equipment as shown in Figure 4-10.
- (2) Set the 205 Receiver controls as follows:

a. FINE TUNING - Midrange	c. Tuning Mode - MAN
b. Reception Mode - AM MAN	d. VIDEO GAIN - MAX CW.

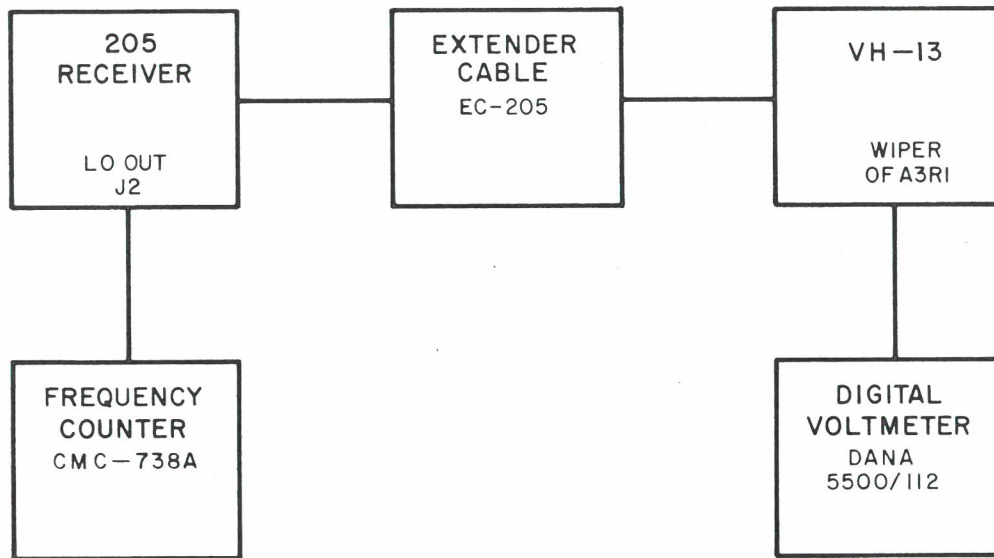

Figure 4-10. Test Equipment Connections, Shaping Amplifier Alignment

NOTE

Controls not specifically referred to may be left in any position, and will not effect the alignment procedure.

- (3) Manually tune the VH-13 over its tuning range in steps to obtain the tuning voltage readouts as shown in Table 4-1. Note the frequency counter readout at each step and compare to the readings and tolerances specified in the table. If the readouts are within tolerance, no adjustment is necessary. If alignment is necessary, turn all shaping amplifier potentiometers maximum CW and proceed to step (4).
- (4) Tune the VH-13 for a voltmeter readout of 0.00 Vdc and adjust R3 for a counter readout of 158.050 MHz.
- (5) Tune for a voltmeter reading of -10.00 Vdc and adjust R5 for a counter readout of 121.400 MHz.
- (6) Repeat step (4) and adjust R3 if necessary.
- (7) With a voltmeter readout of 0.00 Vdc, adjust R27 for a counter readout of 161.400 MHz.
- (8) Tune for a voltmeter reading of +3.50 Vdc and adjust R32 for a counter readout of 175.600 MHz.
- (9) Tune for a voltmeter reading of +6.50 Vdc and adjust R37 for a counter readout of 187.400 MHz.
- (10) Tune for a voltmeter reading of +7.50 Vdc and adjust R42 for a counter readout of 191.500 MHz.
- (11) Tune for a voltmeter reading of +10.00 Vdc and adjust R47 for a counter readout of 201.400 MHz. Repeat steps (4) through (11) making small adjustments as necessary. Repeat step (3) to verify proper shaping amplifier operation.

Table 4-1. Tuning Voltage Versus Frequency Table

Tuning Voltage	Tuned Frequency MHz	LO Frequency MHz	Tolerance kHz	Tuning Voltage	Tuned Frequency MHz	LO Frequency MHz	Tolerance kHz
-10.00	100.0	121.4	±160	+0.50	142.0	163.4	±500
-9.50	102.0	123.4	±400	+1.00	144.0	165.4	±500
-9.00	104.0	125.4	±400	+1.50	146.0	167.4	±500
-8.50	106.0	127.4	±400	+2.00	148.0	169.4	±500
-8.00	108.0	129.4	±400	+2.50	150.0	171.4	±500
-7.50	110.0	131.4	±400	+3.00	152.0	173.4	±500
-7.00	112.0	133.4	±400	+3.50	154.0	175.4	±500
-6.50	114.0	135.4	±400	+4.00	156.0	177.4	±500
-6.00	116.0	137.4	±400	+4.50	158.0	179.4	±500
-5.50	118.0	139.4	±400	+5.00	160.0	181.4	±500
-5.00	120.0	141.4	±400	+5.50	162.0	183.4	±500
-4.50	122.0	143.4	±400	+6.00	164.0	185.4	±500
-4.00	124.0	145.4	±400	+6.50	166.0	187.4	±500
-3.50	126.0	147.4	±400	+7.00	168.0	189.4	±500
-3.00	128.0	149.4	±400	+7.50	170.0	191.4	±500
-2.50	130.0	151.4	±400	+8.00	172.0	193.4	±500
-2.00	132.0	153.4	±400	+8.50	174.0	195.4	±500
-1.50	134.0	155.4	±400	+9.00	176.0	197.4	±500
-1.00	136.0	157.4	±400	+9.50	178.0	199.4	±300
-0.50	138.0	159.4	±400	+10.00	180.0	201.4	±160
0.00	140.0	161.4	±160				

4.5.4 Overall Tracking and Bandwidth Test. - This procedure will insure that the 3-MHz bandwidth requirement for the VH-13 is met. The RF bandwidth is less than the IF bandwidth of the RF tuner subassembly so the response curve displayed will be the actual bandwidth of the VH-13. Proceed as follows:

- (1) Connect the equipment as shown in Figure 4-11. Set the 205 Receiver controls as in 4.5.3, step (2).
- (2) Tune the VH-13 and sweep generator to 100-MHz and adjust the external marker gain, and the 21.4-MHz marker generator levels to provide satisfactory marker level. The 21.4-MHz markers from the HP-608E will beat with the VH-13 local oscillator to produce a center frequency (tuned frequency marker). In addition, use the SM-2000 internal 1-MHz marker.
- (3) Tune the VH-13 and sweep generator from 100-180 MHz and observe the markers to insure that a 3-MHz bandwidth to the 3-dB points is maintained. If a 3-MHz bandwidth cannot be maintained over the entire tuner range, repeat the RF alignment procedure, paragraph 4.5.2.

Figure 4-11

VH-13

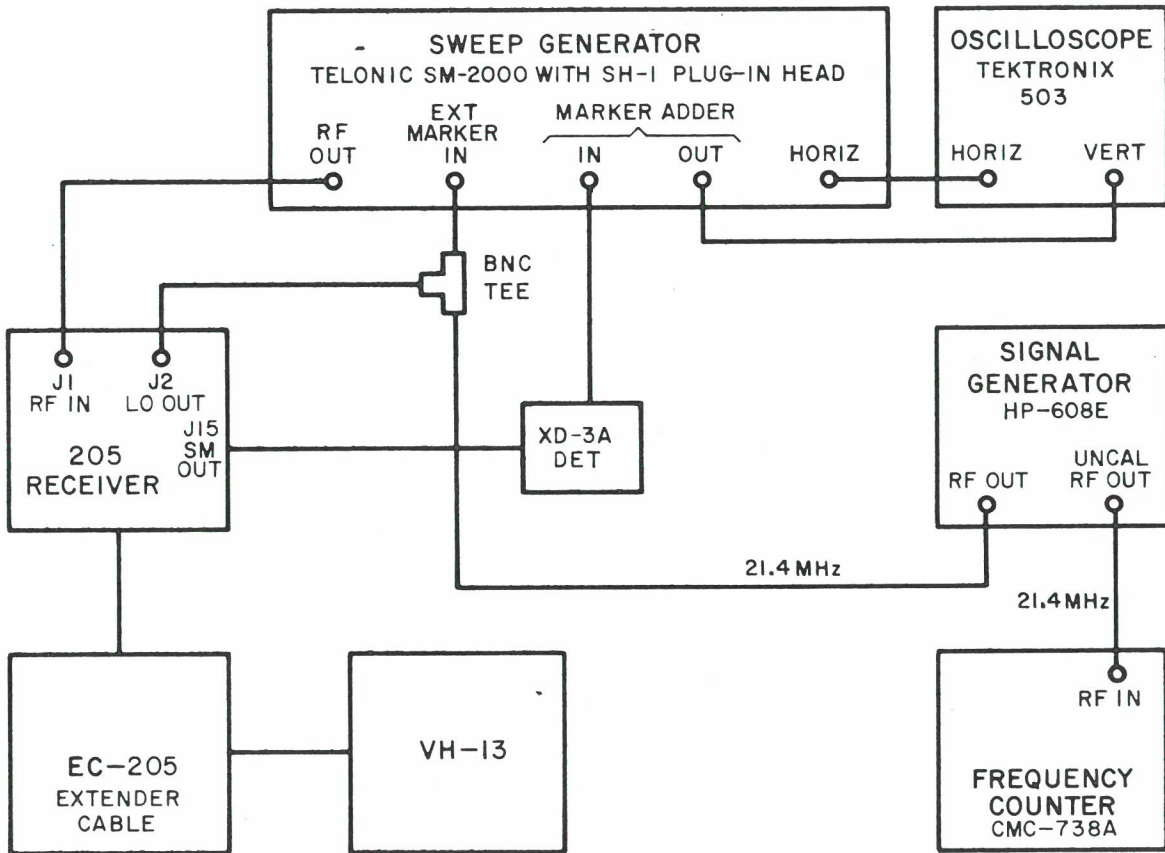

Figure 4-11. Test Equipment Connections, Tracking and Bandwidth Test

Table 4-2. Typical Transistor Element Voltages

Ref. Desig.	Type	Gate 1	Gate 2	Drain	Source	Emitter	Base	Collector
A1Q1	*TA7153	Pin 3 1.11	Pin 2 3.67	Pin 1 15.78	Pin 4 1.36			
A1Q2	2N3933					5.03	5.53	17.16
A1Q3	*2N5397	Pin 3 GND		Pin 2 12.76	Pin 1 1.06			
A1Q4	2N3478					8.90	9.64	17.09
A1Q5	2N3478					8.30	8.82	17.15
A1Q6	2N3478					6.03	6.75	16.40
A1A1Q1	2N5109					-13.52	-13.05	-1.53
A1A1Q2	2N5109					-0.74	GND	9.09

*Field effect transistor pin connections.



- 1. Drain
- 2. Gate No. 2
- 3. Gate No. 1
- 4. Source



- 1. Drain
- 2. Source
- 3. Gate
- 4. Bulk and Case

TEST CONDITIONS: 205 Receiver in MAN mode, 115 Vac input; VH-13 tuned to 180-MHz, no signal input; all readings positive with respect to ground unless otherwise specified. Measurements taken with a Dana Type 5500/112 Digital Voltmeter.

SECTION V

REPLACEMENT PARTS LIST

5.1 UNIT NUMBERING METHOD

The unit numbering method of assigning reference designations (electrical symbol numbers) has been used to identify assemblies, subassemblies (and modules), and parts. An example of the unit method follows:



Read from right to left as: First (1) resistor (R) of
first (1) subassembly (A)

As shown on the main chassis schematic, components which are an integral part of the main chassis have no subassembly designation.

5.2 REFERENCE DESIGNATION PREFIX

Partial reference designations have been used on the equipment and on the illustrations in this manual. The partial reference designations consist of the class letter(s) and identifying item number. The complete reference designations may be obtained by placing the proper prefix before the partial reference designations. Prefixes are provided on drawings and illustrations following the notation "REF DESIG PREFIX."

5.3 LIST OF MANUFACTURERS

<u>Mfr. Code</u>	<u>Name and Address</u>	<u>Mfr. Code</u>	<u>Name and Address</u>
01121	Allen-Bradley Company 1201 South 2nd Street Milwaukee, Wisconsin 53204	14632	Watkins-Johnson Company 700 Quince Orchard Road Gaithersburg, Maryland 20760
01351	Dynamic Gear Company, Incorporated 175 Dixon Avenue Amityville, New York 11701	14949	Trompeter Electronics, Incorporated 8936 Comanche Avenue Chatsworth, California 91311
02735	RCA Corporation Solid State Division Route 202 Somerville, New Jersey 08876	15818	Teledyne Semiconductor 1300 Terra Bella Avenue Mountain View, California 94040
04013	Taurus Corporation 1 Academy Hill Lambertville, New Jersey 08530	20093	Electrical Industries Division of Pepi, Incorporated 693 Central Avenue Murray Hill, New Jersey 07974
04941	Walsco Electronics Corporation 4 South Wyman Rockford, Illinois 61101	25088	Siemens America, Incorporated 186 Wood Avenue South Iselin, New Jersey 08830
07263	Fairchild Camera & Instrument Corp. Semiconductor Division 464 Ellis Street Mountain View, California 94040	27956	Relcom 3333 Hillview Avenue Palo Alto, California 94304

<u>Mfr. Code</u>	<u>Name and Address</u>	<u>Mfr. Code</u>	<u>Name and Address</u>
56289	Sprague Electric Company Marshall Street North Adams, Massachusetts 01247	80131	Electronic Industries Association 2001 Eye Street, N.W. Washington, D. C. 20006
70417	Chrysler Corporation Amplex Division 6501 Harper Avenue Detroit, Michigan 48211	80294	Bourns, Incorporated Instrument Division 6135 Magnolia Avenue Riverside, California 92506
71468	ITT Cannon Electric 666 E. Dyer Road Santa Ana, California 92702	81312	Winchester Electronics Division Litton Industries, Incorporated Main Street & Hillside Avenue Oakville, California 06779
71590	Centralab Electronics Division of Globe-Union Incorporated 5757 N. Green Bay Avenue Milwaukee, Wisconsin 53201	81349	Military Specifications
71744	Chicago Miniature Lamp Works 4433 Ravenswood Avenue Chicago, Illinois 60640	83086	New Hampshire Ball Bearings, Inc. Route 202 Peterborough, New Hampshire 03458
72136	Electro Motive Manufacturing Co., Inc. South Park & John Streets Willimantic, Connecticut 06226	88044	Aeronautical Standards Group Department of Navy & Air Force Silver Spring, Maryland
72982	Erie Technological Products, Inc. 644 West 12th Street Erie, Pennsylvania 16512	91293	Johanson Manufacturing Company P.O. Box 329 Boonton, New Jersey 07005
73138	Beckman Instruments, Incorporated Helipot Division 2500 Harbor Boulevard Fullerton, California 92634	91737	ITT Gremar Incorporated 922 South Lyon Street Santa Ana, California 92705
74868	Bunker Ramo Corporation The Amphenol RF Division 33 East Franklin Street Danbury, Connecticut 06810	96906	Military Standards
79136	Waldes Kohinoor Incorporated 47-16 Austel Place Long Island City, New York 11101	99848	Wilco Corporation 4030 West 10th Street P.O. Box 22248 Indianapolis, Indiana 46222

5.4 PARTS LIST

The parts list which follows contains all electrical parts used in the equipment and certain mechanical parts which are subject to unusual wear or damage. When ordering replacement parts from the Watkins-Johnson Company, specify the type and serial number of the equipment and the reference designation and description of each part ordered. The list of manufacturers provided in paragraph 5.3 and the manufacturer's part number for components are included as a guide to the user of the equipment in the field. These parts may not necessarily agree with the parts installed in the equipment; however, the parts specified in this list will provide satisfactory operation of the equipment. Replacement parts may be obtained from any manufacturer as long as the physical

and electrical parameters of the part selected agree with the original indicated part. In the case of components defined by a military or industrial specification, a vendor which can provide the necessary component is suggested as a convenience to the user.

NOTE

As improved semiconductors become available it is the policy of Watkins-Johnson to incorporate them in proprietary products. For this reason some transistors, diodes and integrated circuits installed in the equipment may not agree with those specified in the parts lists and schematic diagrams of this manual. However, the semiconductors designated in the manual may be substituted in every case with satisfactory results.

5.4.1 VH-13 Tuning Head, Main Chassis

REF DESIG	DESCRIPTION	QTY. PER ASSY.	MANUFACTURER'S PART NO.	MFR. CODE
A1	RF TUNER (100-180 MHz)	1	71281	14632
A2	SHAPING AMPLIFIER	1	79844-3	14632
A3	GEAR TRAIN ASSEMBLY	1	8588	14632
J1	CONNECTOR, RECEPTACLE, MULTIPIN	1	SRE-14SNSS	81312
MP1	KNOB SPINNER	1	23625-1	14632
MP2	WINDOW	1	11448-4	14632
MP3	WINDOW	1	11449-1	14632
MP4	LOCK ASSEMBLY	1	22247-1	14632
P1	CONNECTOR, PLUG, PUSH-ON SERIES, Part of W1	2	19699-1	91737
P2	Same as P1, Part of W2			
P3	CONNECTOR, PLUG, MULTIPIN	1	DAM-11W1P	71468
P3A1	CONNECTOR, PLUG, COAXIAL INSERT, Part of W3	1	DM53740-5001	71468
P4	CONNECTOR, PLUG, MULTIPIN	1	DAM-15P	71468
P5	CONNECTOR, PLUG, BNC SERIES Part of W1	2	PL-25	14949
P6	Same as P5, Part of W2			
P7	CONNECTOR, PLUG, MB SERIES, Part of W3	1	45775	74868
W1	CABLE & CONNECTOR ASSEMBLY	1	30020-1122	14632
W2	CABLE & CONNECTOR ASSEMBLY	1	30020-1121	14632
W3	CABLE & CONNECTOR ASSEMBLY	1	30020-1123	14632

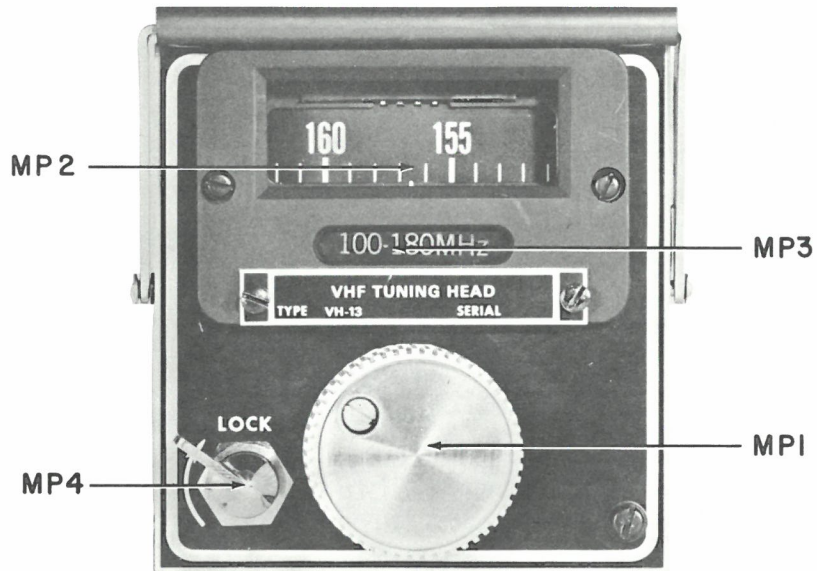

Figure 5-1. Type VH-13 Tuning Head, Front View,
Location of Components

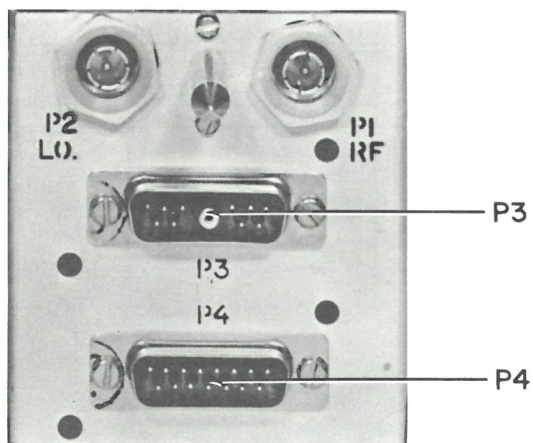

Figure 5-2. Type VH-13 Tuning Head, Rear View,
Location of Components

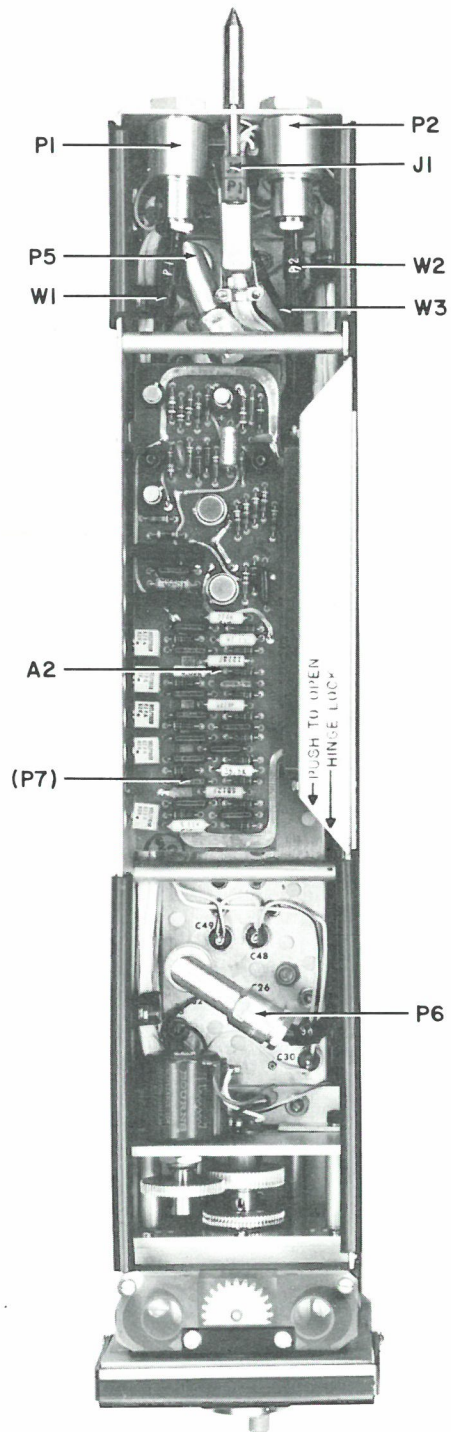

Figure 5-3. Type VH-13 Tuning Head, Top View, Location of Components

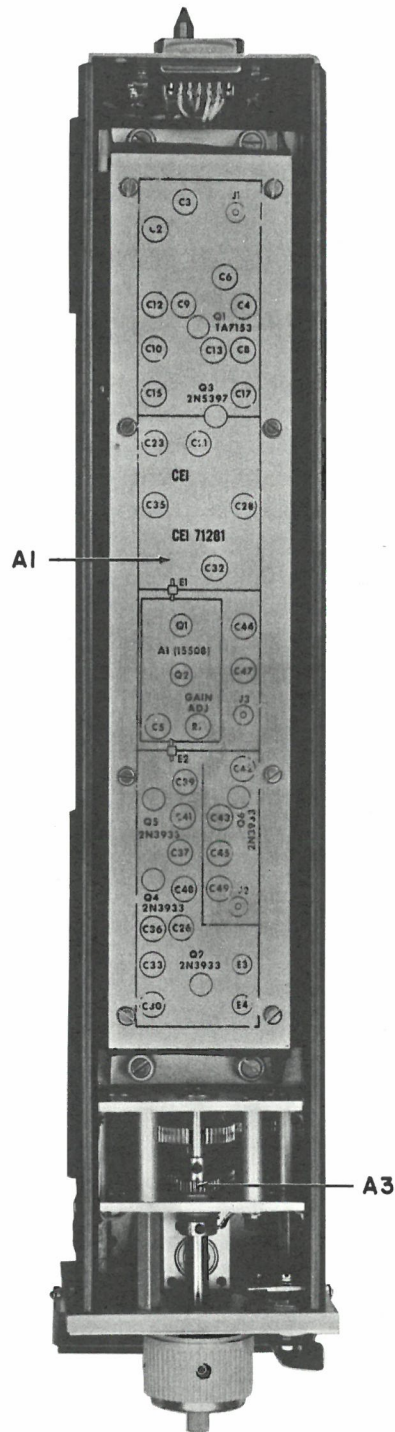

Figure 5-4. Type VH-13 Tuning Head, Bottom View, Location of Components

5.4.2 Type 71281 100 MHz-180 MHz Tuner

REF DESIG PREFIX A1

REF DESIG	DESCRIPTION	QTY. PER ASSY.	MANUFACTURER'S PART NO.	MFR. CODE
A1	MIXER/IF AMPLIFIER	1	15508	14632
C1	CAPACITOR, CERAMIC, DISC: 0.01 μ F, 20%, 200V	5	8131-026-Z5U0-103M	72982
C2	CAPACITOR, CERAMIC, FEEDTHRU: 1000 pF, GMV, 500V	14	FA5C-102W	01121
C3	CAPACITOR, VARIABLE, AIR: 0.8-10 pF, 250V	5	2954	91293
C4	Same as C2			
C5	Same as C1			
C6	Same as C3			
C7	CAPACITOR, MICA, DIPPED: 220 pF, 5%, 500V	4	CM05FD221J03	81349
C8	Same as C2			
C9	CAPACITOR, CERAMIC, STANDOFF: 470 pF, 20%, 500V	10	SS5A-4712	01121
C10	Same as C2			
C11	Same as C1			
C12	CAPACITOR, CERAMIC, FEEDTHRU: 470 pF, 20%, 500V	1	FA5C-4712	01121
C13	Same as C9			
C14	CAPACITOR, MICA, DIPPED: 330 pF, 5%, 500V	3	CM05FD331J03	81349
C15	Same as C9			
C16	Same as C7			
C17	Same as C2			
C18	CAPACITOR, ELECTROLYTIC, TANTALUM:100 μ F, 20%, 25V	1	109D107X0025F2	56289
C19	CAPACITOR, MICA, DIPPED: 15 pF, 5%, 500V	1	CM05CD150J03	81349
C20	CAPACITOR, MICA, DIPPED: 20 pF, 5%, 500V	1	CM05ED200J03	81349
C21	Same as C9			
C22	CAPACITOR, CERAMIC, TUBULAR: 5.6 pF, \pm 0.25 pF, 500V	1	301-000-C0H0-569C	72982
C23	Same as C2			
C24	Same as C7			
C25	CAPACITOR, MICA, DIPPED: 820 pF, 5%, 500V	1	DM15-821J	72136
C26	Same as C3			
C27	Same as C1			
C28	Same as C3			
C29	CAPACITOR, CERAMIC, TUBULAR: 1.0 pF, \pm 0.1 pF, 500V	1	301-000-C0K0-109B	72982
C30	Same as C2			
C31	CAPACITOR, MICA, DIPPED: 1000 pF, 5%, 500V	1	DM15-102J	72136
C32	Same as C2			
C33	Same as C2			

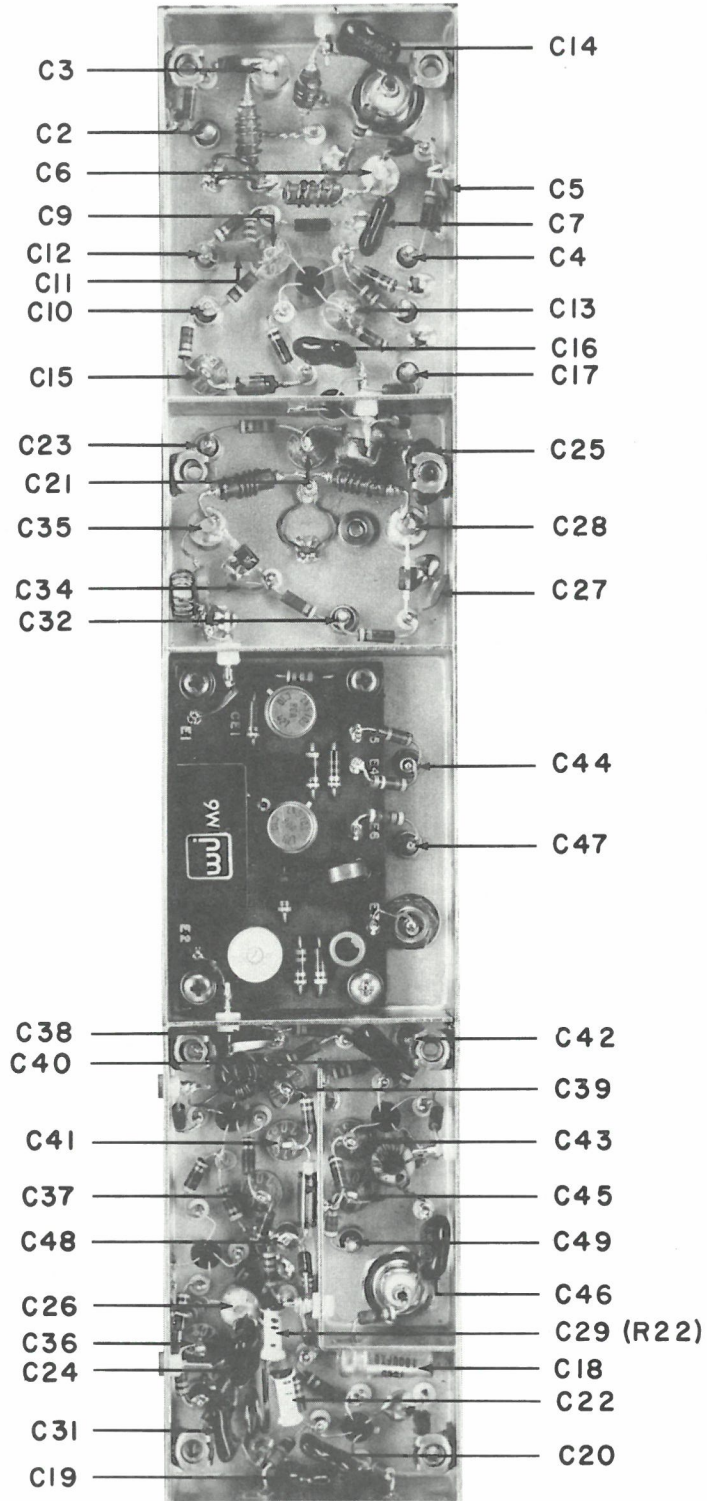

Figure 5-5. Type 71281 100-180 MHz Tuner (A1), Location of Components

REF DESIG PREFIX A1

REF DESIG	DESCRIPTION	QTY. PER ASSY.	MANUFACTURER'S PART NO.	MFR: CODE
C34	Same as C1			
C35	Same as C3			
C36	Same as C9			
C37	Same as C9			
C38	Same as C14			
C39	Same as C9			
C40	Same as C7			
C41	Same as C9			
C42	Same as C2			
C43	Same as C9			
C44	Same as C2			
C45	Same as C9			
C46	Same as C14			
C47 thru C49	Same as C2			
CR1	DIODE	1	15780-1	14632
CR2	DIODE	1	1N462A	80131
CR3	DIODE	1	BB109	25088
CR4	DIODE	2	1N4003	80131
CR5	Same as CR4			
E1	TERMINAL, INSULATED, FEEDTHRU	2	SFU-16	04013
E2	Same as E1			
E3	TERMINAL, INSULATED, FEEDTHRU	2	AB-S-40WPP	20093
E4	Same as E3			
J1	CONNECTOR, RECEPTACLE, BNC SERIES	2	UG-1094/U	81349
J2	Same as J1			
J3	CONNECTOR, RECEPTACLE, MB SERIES	1	46025	74868
L1	COIL, FIXED	1	15720-1	14632
L2	COIL, FIXED	3	21210-59	14632
L3	COIL, FIXED: 0.56 μ H	1	202-11	99848
L4	COIL, FIXED	1	22292-3	14632
L5	COIL, FIXED	1	22295-6	14632
L6	Same as L2			
L7	COIL, FIXED	1	15720-2	14632
L8	Same as L2			

Change I 3/17/75

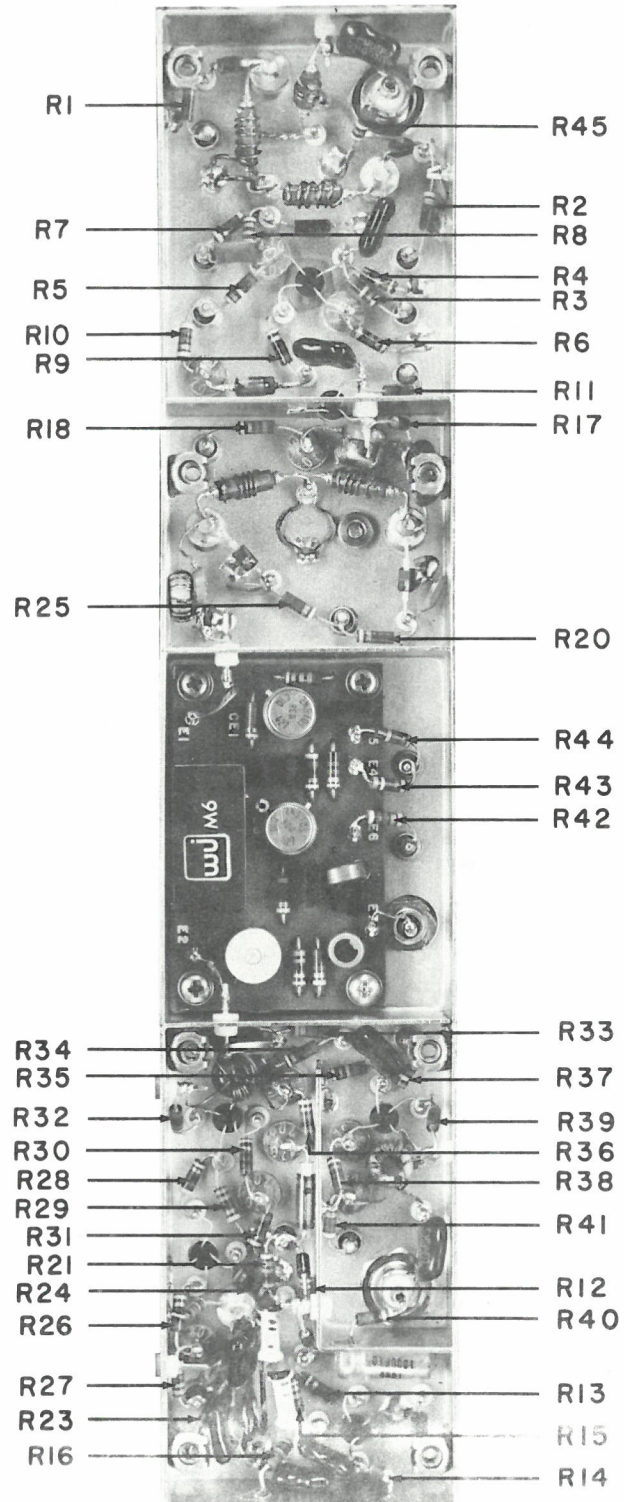

Figure 5-6. Type 71281 100-180 MHz Tuner (A1),
Location of Components

REF DESIG PREFIX A1

REF DESIG	DESCRIPTION	QTY. PER ASSY.	MANUFACTURER'S PART NO.	MFR. CODE
L9	COIL, FIXED	1	1131-40	14632
L10	COIL, FIXED	1	21210-58	14632
MP1	COVER	1	22139-3	14632
P1	CONNECTOR, PLUG, MULTIPIN	1	SRE-14PNSSH13	81312
Q1	TRANSISTOR	1	TA7153	02735
Q2	TRANSISTOR	4	2N3478	80131
Q3	TRANSISTOR	1	2N5397	80131
Q4	Same as Q2			
Q5	Same as Q2			
Q6	Same as Q2			
R1	RESISTOR, FIXED, COMPOSITION: 2.2 k Ω , 5%, 1/4W	5	RCR07G222JS	81349
R2	Same as R1			
R3	RESISTOR, FIXED, COMPOSITION: 150 k Ω , 5%, 1/4W	2	RCR07G154JS	81349
R4	RESISTOR, FIXED, COMPOSITION: 10 k Ω , 5%, 1/4W	1	RCR07G103JS	81349
R5	Same as R3			
R6	RESISTOR, FIXED, COMPOSITION: 300 Ω , 5%, 1/4W	1	RCR07G301JS	81349
R7	RESISTOR, FIXED, COMPOSITION: 4.7 k Ω , 5%, 1/4W	1	RCR07G472JS	81349
R8	RESISTOR, FIXED, COMPOSITION: 33 k Ω , 5%, 1/4W	1	RCR07G333JS	81349
R9	RESISTOR, FIXED, COMPOSITION: 10 Ω , 5%, 1/4W	7	RCR07G100JS	81349
R10	RESISTOR, FIXED, COMPOSITION: 470 Ω , 5%, 1/4W	3	RCR07G471JS	81349
R11	RESISTOR, FIXED, COMPOSITION: 2 k Ω , 5%, 1/4W	1	RCR07G202JS	81349
R12	RESISTOR, FIXED, COMPOSITION: 270 Ω , 5%, 1/4W	1	RCR07G271JS	81349
R13	Same as R9			
R14	RESISTOR, FIXED, COMPOSITION: 1.8 k Ω , 5%, 1/4W	2	RCR07G182JS	81349
R15	RESISTOR, FIXED, COMPOSITION: 18 k Ω , 5%, 1/4W	2	RCR07G183JS	81349
R16	Same as R15			
R17	Same as R9			
R18	RESISTOR, FIXED, COMPOSITION; 560 Ω , 5%, 1/4W	1	RCR07G561JS	81349
R19	RESISTOR, FIXED, COMPOSITION: 68 k Ω , 5%, 1/4W	1	RCR07G683JS	81349
R20	Same as R1			
R21	RESISTOR, FIXED, COMPOSITION: 30 k Ω , 5%, 1/4W	1	RCR07G303JS	81349
R22	RESISTOR, FIXED, COMPOSITION: 39 k Ω , 5%, 1/4W	2	RCR07G393JS	81349
R23	Same as R1			
R24	RESISTOR, FIXED, COMPOSITION: 47 Ω , 5%, 1/4W	2	RCR07G470JS	81349

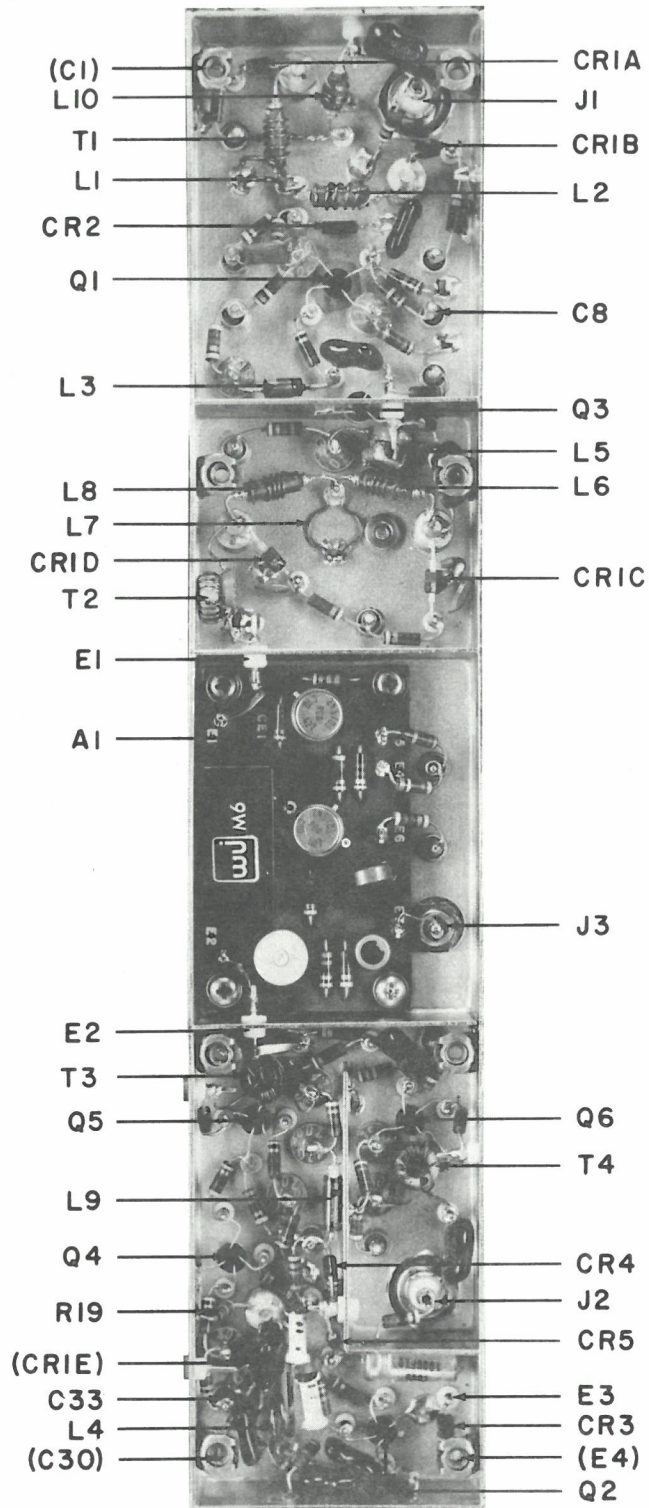

Figure 5-7. Type 71281 100-180 MHz Tuner (A1),
Location of Components

REF DESIG PREFIX A1

REF DESIG	DESCRIPTION	QTY. PER ASSY.	MANUFACTURER'S PART NO.	MFR. CODE
R25	Same as R1			
R26	Same as R9			
R27	RESISTOR, FIXED, COMPOSITION: 330 Ω , 5%, 1/4W	1	RCR07G331JS	81349
R28	Same as R24			
R29	RESISTOR, FIXED, COMPOSITION: 3.3 k Ω , 5%, 1/4W	1	RCR07G332JS	81349
R30	Same as R9			
R31	RESISTOR, FIXED, COMPOSITION: 1 k Ω , 5%, 1/4W	1	RCR07G102JS	81349
R32	Same as R9			
R33	RESISTOR, FIXED, COMPOSITION: 820 Ω , 5%, 1/4W	1	RCR07G821JS	81349
R34	RESISTOR, FIXED, COMPOSITION: 82 Ω , 5%, 1/4W	1	RCR07G820JS	81349
R35	RESISTOR, FIXED, COMPOSITION: 27 k Ω , 5%, 1/4W	1	RCR07G273JS	81349
R36	RESISTOR, FIXED, COMPOSITION: 100 Ω , 5%, 1/4W	1	RCR07G101JS	81349
R37	Same as R22			
R38	Same as R14			
R39	Same as R9			
R40	RESISTOR, FIXED, COMPOSITION: 51 Ω , 5%, 1/4W	1	RCR07G510JS	81349
R41	Same as R10			
R42	Same as R10			
R43	RESISTOR, FIXED, COMPOSITION: 3.9 k Ω , 5%, 1/4W	1	RCR07G392JS	81349
R44	RESISTOR, FIXED, COMPOSITION: 240 Ω , 5%, 1/4W	1	RCR07G241JS	81349
R45	RESISTOR, FIXED, COMPOSITION: 100 k Ω , 5%, 1/4W	1	RCR07G104JS	81349
T1	TRANSFORMER	1	11464-46	14632
T2	TRANSFORMER	1	22295-7	14632
T3	TRANSFORMER	1	22294-4	14632
T4	TRANSFORMER	1	22294-1	14632

5.4.2.1 Part 15508 Mixer/IF Amplifier

REF DESIG PREFIX A1A1

REF DESIG	DESCRIPTION	QTY. PER ASSY.	MANUFACTURER'S PART NO.	MFR. CODE
C1	CAPACITOR, CERAMIC, DISC: 1000 pF, 10%, 200V	3	CK05BX102K	81349
C2	Same as C1			
C3	CAPACITOR, CERAMIC, DISC: 0.01 μ F, 10%, 200V	2	CK06BX103K	81349
C4	Same as C3			
C5	CAPACITOR, VARIABLE, CERAMIC: 9-35 pF, 350V	1	538-011-D9-35	72982
C6	Same as C1			
Q1	TRANSISTOR	2	2N5109	80131
Q2	Same as Q1			
R1	RESISTOR, FIXED, COMPOSITION: 8.2 k Ω , 5%, 1/4W	1	RCR07G822JS	81349
R2	RESISTOR, FIXED, COMPOSITION: 510 Ω , 5%, 1/4W	1	RCR07G511JS	81349
R3	RESISTOR, FIXED, COMPOSITION: 47 Ω , 5%, 1/4W	2	RCR07G470JS	81349
R4	RESISTOR, FIXED, COMPOSITION: 5.6 Ω , 5%, 1/4W	1	RCR07G5R6JS	81349
R5	Same as R3			
R6	RESISTOR, FIXED, COMPOSITION: 150 Ω , 5%, 1/4W	1	RCR07G151JS	81349
R7	RESISTOR, VARIABLE, FILM: 100 Ω 30%, 1/2W	1	62PR100	73138
R8	RESISTOR, FIXED, COMPOSITION: 33 Ω , 5%, 1/4W	1	RCR07G330JS	81349
T1	TRANSFORMER	1	21428-7	14632
U1	DOUBLE BALANCED MIXER	1	M6	27956

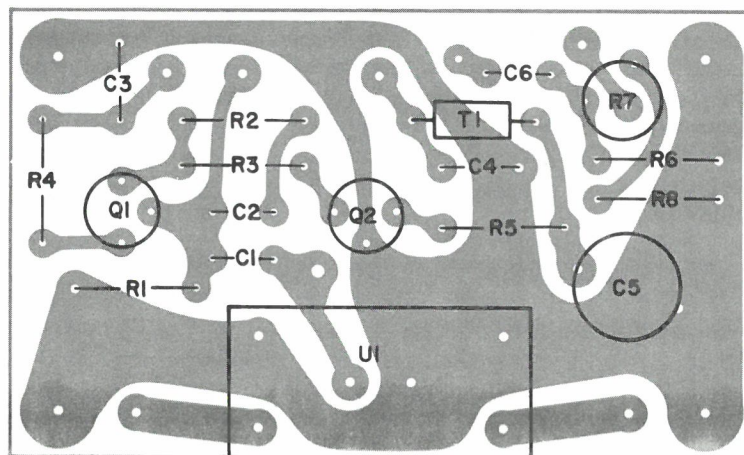

Figure 5-8. Part 15508 Mixer/IF Amplifier (A1A1),
Location of Components

5.4.3 Type 79844-3 100-180 MHz Shaping Amplifier

REF DESIG PREFIX A2

REF DESIG	DESCRIPTION	QTY. PER ASSY.	MANUFACTURER'S PART NO.	MFR. CODE
C1	CAPACITOR, ELECTROL., TANTALUM: 4.7 μ F, 10%, 100V	1	109D475X9100C2	56289
C2	CAPACITOR, CERAMIC, DISC: 1000 pF, 10%, 200 V	1	CK05BX102K	81349
C3	CAPACITOR, CERAMIC, DISC: 5000 pF, 20%, 100 V	1	C023B101E502M	56289
CR1	DIODE	18	1N458A	80131
CR2	Same as CR1			
CR3	Same as CR1			
CR4	NOT USED			
CR5	Same as CR1			
CR6	Same as CR1			
CR7	Same as CR1			
CR8	Same as CR1			
CR9	Same as CR1			
CR10	Same as CR1			
CR11	Same as CR1			
CR12	Same as CR1			
CR13	Same as CR1			
CR14	Same as CR1			
CR15	Same as CR1			
CR16	Same as CR1			
CR17	Same as CR1			
CR18	Same as CR1			
CR19	Same as CR1			
Q1	TRANSISTOR	3	2N2907	80131
Q2	TRANSISTOR	2	U1899E	15818
Q3	Same as Q2			
Q4	Same as Q1			
Q5	Same as Q1			
R1	RESISTOR, FIXED, COMPOSITION: 5.6 k Ω , 5%, 1/4W	1	RCR07G562JS	81349
R2	RESISTOR, FIXED, COMPOSITION: 4.7 k Ω , 5%, 1/4W	1	RCR07G472JS	81349
R3	RESISTOR, VARIABLE, WIRE-WOUND: 5 k Ω , 10%, 1W	2	3005P-1-502	80294
R4*	RESISTOR, FIXED, FILM: 12.1 k Ω , 1%, 1/4W	2	RN60D1212F	81349
R5	Same as R3			
R6*	RESISTOR, FIXED, FILM: 18.2 k Ω , 1%, 1/4W	1	RN60D1822F	81349
R7*	RESISTOR, FIXED, FILM: 68.1 k Ω , 1%, 1/4W	3	RN60D6812F	81349

* Nominal value; final value factory selected.

REF DESIG PREFIX A2

REF DESIG	DESCRIPTION	QTY. PER ASSY.	MANUFACTURER'S PART NO.	MFR. CODE
R8	RESISTOR, FIXED, COMPOSITION: 12 k Ω , 5%, 1/4W	1	RCR07G123JS	81349
R9	RESISTOR, FIXED, COMPOSITION: 10 k Ω , 5%, 1/4W	1	RCR07G103JS	81349
R10	RESISTOR, FIXED, COMPOSITION: 1 M Ω , 5%, 1/4W	4	RCR07G105JS	81349
R11	Same as R10			
R12	RESISTOR, FIXED, COMPOSITION: 100 Ω , 5%, 1/4W	2	RCR07G101JS	81349
R13	RESISTOR, FIXED, COMPOSITION: 2.7 k Ω , 5%, 1/4W	1	RCR07G272JS	81349
R14	RESISTOR, FIXED, COMPOSITION: 22 M Ω , 5%, 1/4W	2	RCR07G226JS	81349
R15*	RESISTOR, FIXED, COMPOSITION: 330 Ω , 5%, 1/4W	1	RCR07G331JS	81349
R16	Same as R14			
R17	RESISTOR, FIXED, COMPOSITION: 3.9 M Ω , 5%, 1/4W	2	RCR07G395JS	81349
R18	Same as R10			
R19	Same as R17			
R20	RESISTOR, FIXED, COMPOSITION: 470 k Ω , 5%, 1/4W	2	RCR07G474JS	81349
R21	Same as R10			
R22	Same as R20			
R23	RESISTOR, FIXED, COMPOSITION: 2.2 M Ω , 5%, 1/4W	1	RCR07G225JS	81349
R24*	Same as R7			
R25*	RESISTOR, FIXED, FILM: 86.6 k Ω , 1%, 1/4W	1	RN60D8662F	81349
R26*	Same as R4			
R27	RESISTOR, VARIABLE, FILM: 2 k Ω , 30%, 1/2W	5	62PAR2K	73138
R28*	RESISTOR, FIXED, FILM: 1.50 k Ω , 1%, 1/4W	1	RN60D1501F	81349
R29*	RESISTOR, FIXED, FILM: 75 k Ω , 1%, 1/4W	1	RN60D7502F	81349
R30*	RESISTOR, FIXED, FILM: 56.2k Ω , 1%, 1/4W	1	RN60D5622F	81349
R31*	RESISTOR, FIXED, FILM: 9.09k Ω , 1%, 1/4W	1	RN60D9091F	81349
R32	Same as R27			
R33*	RESISTOR, FIXED, FILM: 4.12k Ω , 1%, 1/4W	1	RN60D4121F	81349
R34*	Same as R7			
R35*	RESISTOR, FIXED, FILM 39.2 k Ω , 1%, 1/4W	1	RN60D3922F	81349
R36*	RESISTOR, FIXED, FILM: 8.06k Ω , 1%, 1/4W	1	RN60D8061F	81349
R37	Same as R27			
R38*	RESISTOR, FIXED, FILM: 5.36 k Ω , 1%, 1/4W	1	RN60D5361F	81349
R39*	Same as R29			
R40*	RESISTOR, FIXED, FILM: 36.5k Ω , 1%, 1/4W	1	RN60D3652F	81349
R41*	RESISTOR, FIXED, FILM: 6.8k Ω , 1%, 1/4W	1	RN60D6811F	81349

* Nominal value; final value to be factory selected.

Figure 5-9

VH-13

REF DESIG PREFIX A2

REF DESIG	DESCRIPTION	QTY. PER ASSY.	MANUFACTURER'S PART NO.	MFR. CODE
R42	Same as R27			
R43*	RESISTOR, FIXED, FILM: 7.15kΩ, 1%, 1/4W	1	RN60D7151F	81349
R44*	RESISTOR, FIXED, FILM: 100 kΩ, 1%, 1/4W	1	RN60D1003F	81349
R45*	RESISTOR, FIXED, FILM: 30.1 kΩ, 1%, 1/4W	1	RN60D3012F	81349
R46*	RESISTOR, FIXED, FILM: 5.11 kΩ, 1%, 1/4W	1	RN60D5111F	81349
R47	Same as R27			
R48*	Same as R31			
R49	Same as R12			
U1	INTEGRATED CIRCUIT	2	U5B7741393	07263
U2	Same as U1			
VR1	VOLTAGE REGULATOR	1	1N759A	80131

* Nominal value; final value to be factory selected.

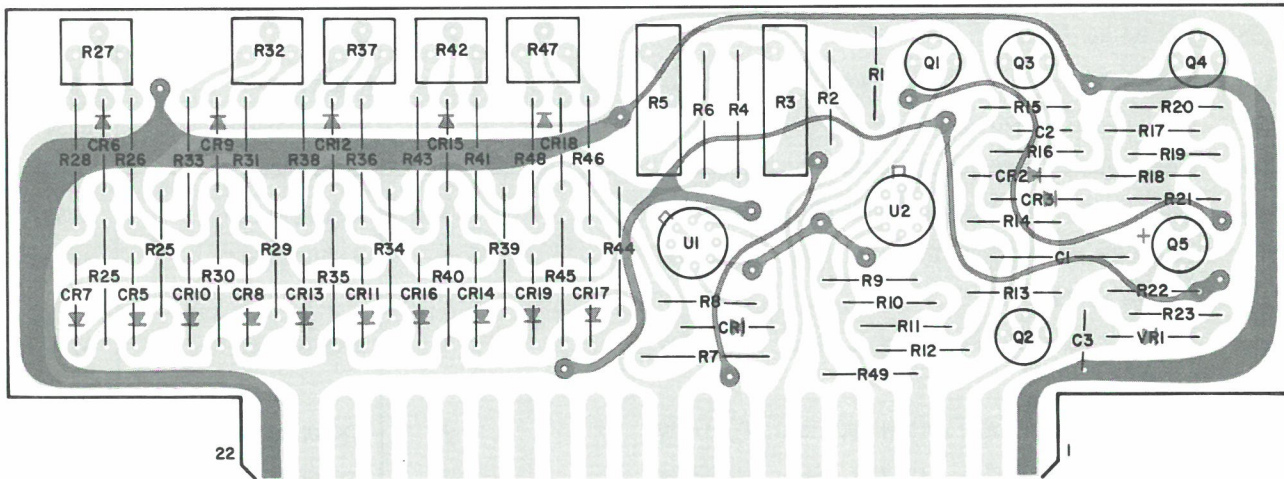

Figure 5-9. Type 79844-3 Shaping Amplifier (A2), Location of Components

5.4.4 Type 8588 Gear Train Assembly

REF DESIG PREFIX A3

REF DESIG	DESCRIPTION	QTY. PER ASSY.	MANUFACTURER'S PART NO.	MFR. CODE
DS1	LAMP, INCANDESCENT: 6V, 0.06A	3	CM8-683	71744
DS2	Same as DS1			
DS3	Same as DS1			
R1	RESISTOR, VARIABLE, PRECISION: 10 k Ω , 10%, 2W	1	8106-R10K-L.25	73138

Note: For mechanical parts, see exploded view

REF DESIG	DESCRIPTION	QTY. PER ASSY.	MANUFACTURER'S PART NO.	MFR. CODE
1	LIGHT BOARD ASSEMBLY	1	15531	14632
2	LAMP, INCANDESCENT	REF	CM-683	71744
3	LIGHT BAR	1	13963	14632
4	GUIDE PLATE	1	14122-1	14632
5	TOP GEAR PLATE	1	15652-1	14632
6	#2-56 x 1/4 PAN HEAD MACHINE SCREW	7	MS519573	96906
7	#2 LOCKWASHER	9	MS35338-134	96906
8	#2 FLAT WASHER	3	MS15795-802	96906
9	TENSION SPRING	2	ARC232	73682
10	#2-56 x 1/4 FILLISTER HEAD MACHINE SCREW	2	NAS620C2	80205
11	COLLAR	1	11581-10	14632
12	#4-40 x 1/8 SETSCREW	13	SSCR4-40x1/8HT TR	56878
13	TENSION SPRING	1	3502-14-47	78189
14	THRUST WASHER	1	TT504	70417
15	SHAFT	1	15641-1	14632
16	SUPPORT PLATE	1	15655-1	14632
17	BEARING	6	SFR-33MM	83086
18	BEVEL GEAR	1	11135-2	14632
19	PINION BEVEL GEAR	1	11136-1	14632
20	TENSION SPRING	1	15654-1	14632
21	SHAFT	1	12974-7	14632
22	TAPE CHAMBER	1	15356-1	14632
23	DIAL, TAPE	1	32266-1	14632
24	#6 FLAT WASHER	5	MS15795-805	96906
25	#6 LOCKWASHER	3	MS35338-136	96906
26	#6-32 x 1/4 PAN HEAD MACHINE SCREW	2	MS51957-26	96906
27	TAPE DRIVE GEAR	1	14065	14632
28	GUIDE PLATE	1	14122-1	14632
29	ANGLE PLATE	1	15357-1	14632
30	#2-56 x 1/4 FLAT HEAD MACHINE SCREW	4	MS35249-10	96906
31	SHIM	1	SSS-23	01351
32	#6-32 x 3/8 HEXAGON SOCKET CAP SCREW	3	MS16995-17	96906
33	SHOULDER SPACER	3	20755-71	14632
34	FRONT GEAR PLATE	1	22245-1	14632

Revised 3/17/75

REF DESIG	DESCRIPTION	QTY. PER ASSY.	MANUFACTURER'S PART NO.	MFR. CODE
35	SPACER	4	20757-32	14632
36	SHAFT	1	12974-8	14632
37	RETAINING RING	1	5100-18	79136
38	ANTIBACKLASH GEAR, 64P-60T	1	20178-2	14632
39	SPUR GEAR, 64P-30T	1	20189-16	14632
40	CLUTCH BEARING	1	11582-7	14632
41	SPUR GEAR, 64P-60T	1	20189-18	14632
42	SCREW	REF	Part of Potentiometer	-
43	ANTIBACKLASH GEAR, 64P-60T	1	20178-3	14632
44	RETAINING RING	REF	Part of Potentiometer	-
45	NUT	REF	Part of Potentiometer	-
46	WASHER	REF	Part of Potentiometer	-
47	REAR GEAR PLATE	1	22246-1	14632
48	#6-32 x 1/2 FLAT HEAD MACHINE SCREW	2	MS24693-C28	96906
49	SPACER	REF	Part of Potentiometer	-
50	RETAINING RING	REF	Part of Potentiometer	-
51	POTENTIOMETER	REF	8106R-10K-L-.25	73138

Revised 3/17/75

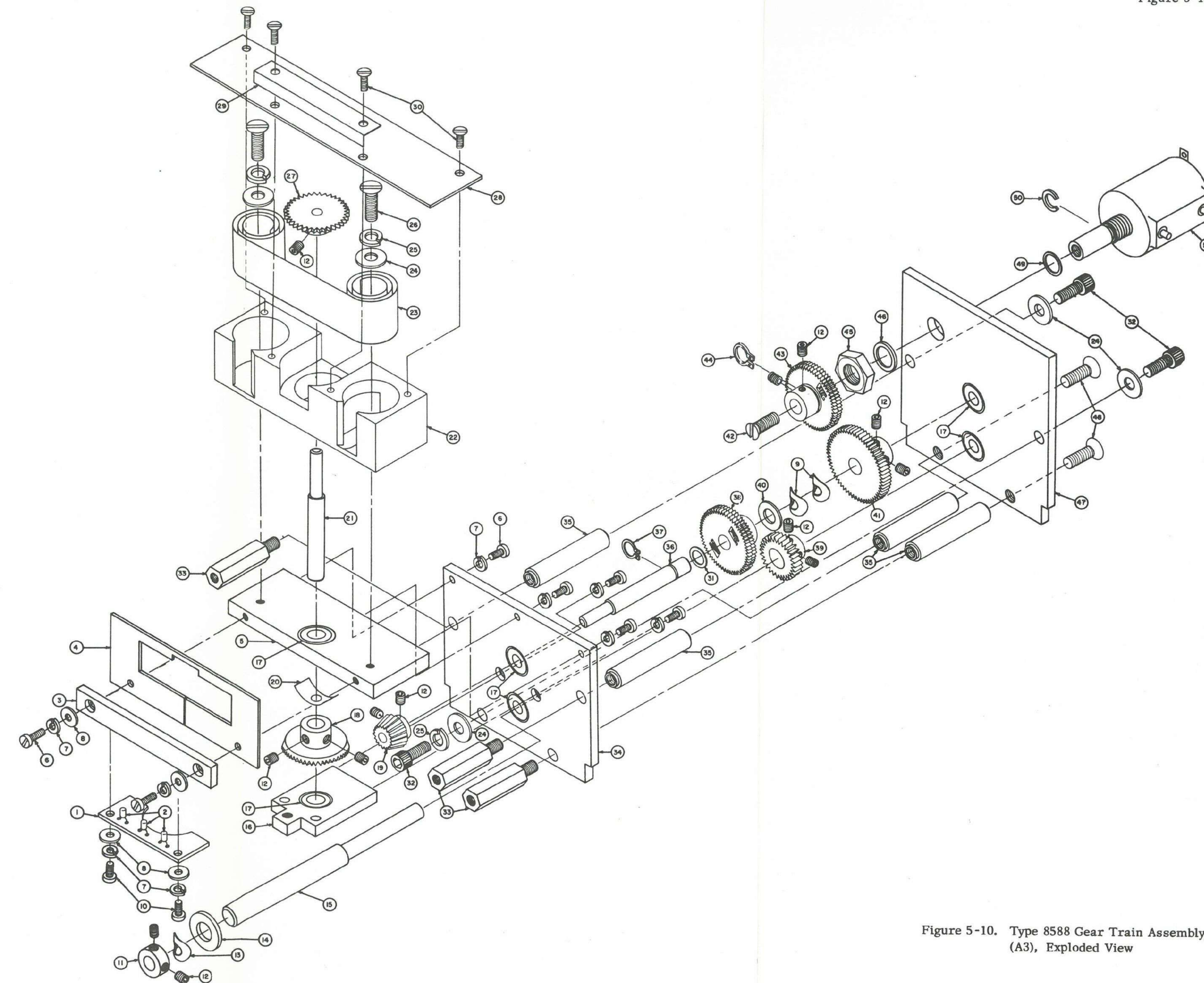
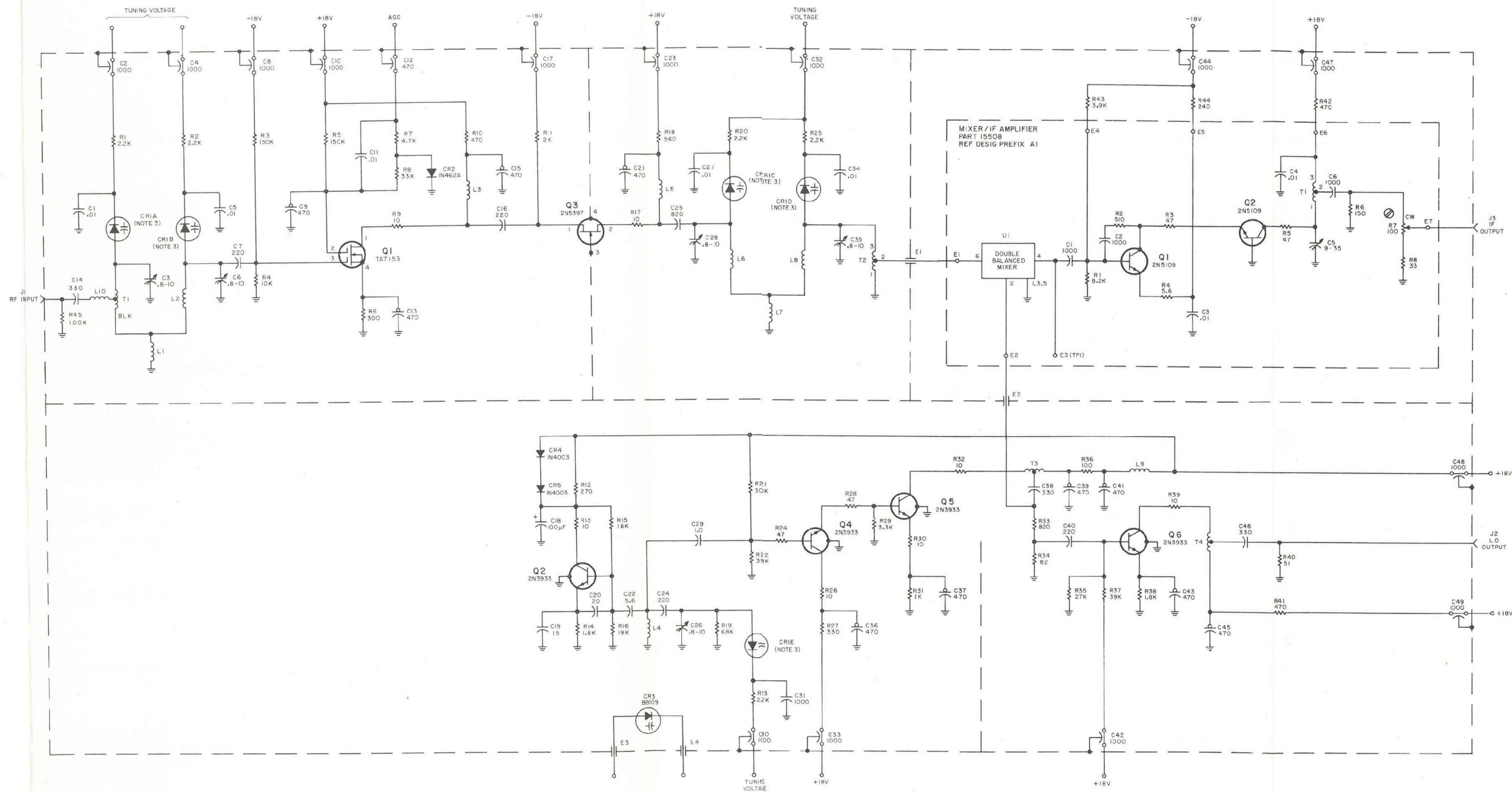

Figure 5-10. Type 8588 Gear Train Assembly (A3), Exploded View

SECTION VI

SCHEMATIC DIAGRAMS



- NOTES:
- UNLESS OTHERWISE SPECIFIED:
 - a) RESISTANCE IS MEASURED IN OHMS, $\pm 5\%$, 1/4W
 - b) CAPACITANCE IS MEASURED IN pF.
 - THE FOLLOWING NOTATIONS ARE USED ON POTENTIOMETERS:
 - a) CW INDICATES CLOCKWISE ROTATION.
 - b) \odot INDICATES SCREWDRIVER ADJUSTMENT.
 - SEE DWG 15780-1 FOR REQUIREMENTS OF MATCHED SET OF 5 DIODES FOR CR1.
 - ON PLUG P1, THE FEMALE GUIDE PIN IS NEXT TO PIN A AS SHOWN IN DETAIL B.
 - FOR WIRING TO PLUG SEE DETAIL A.

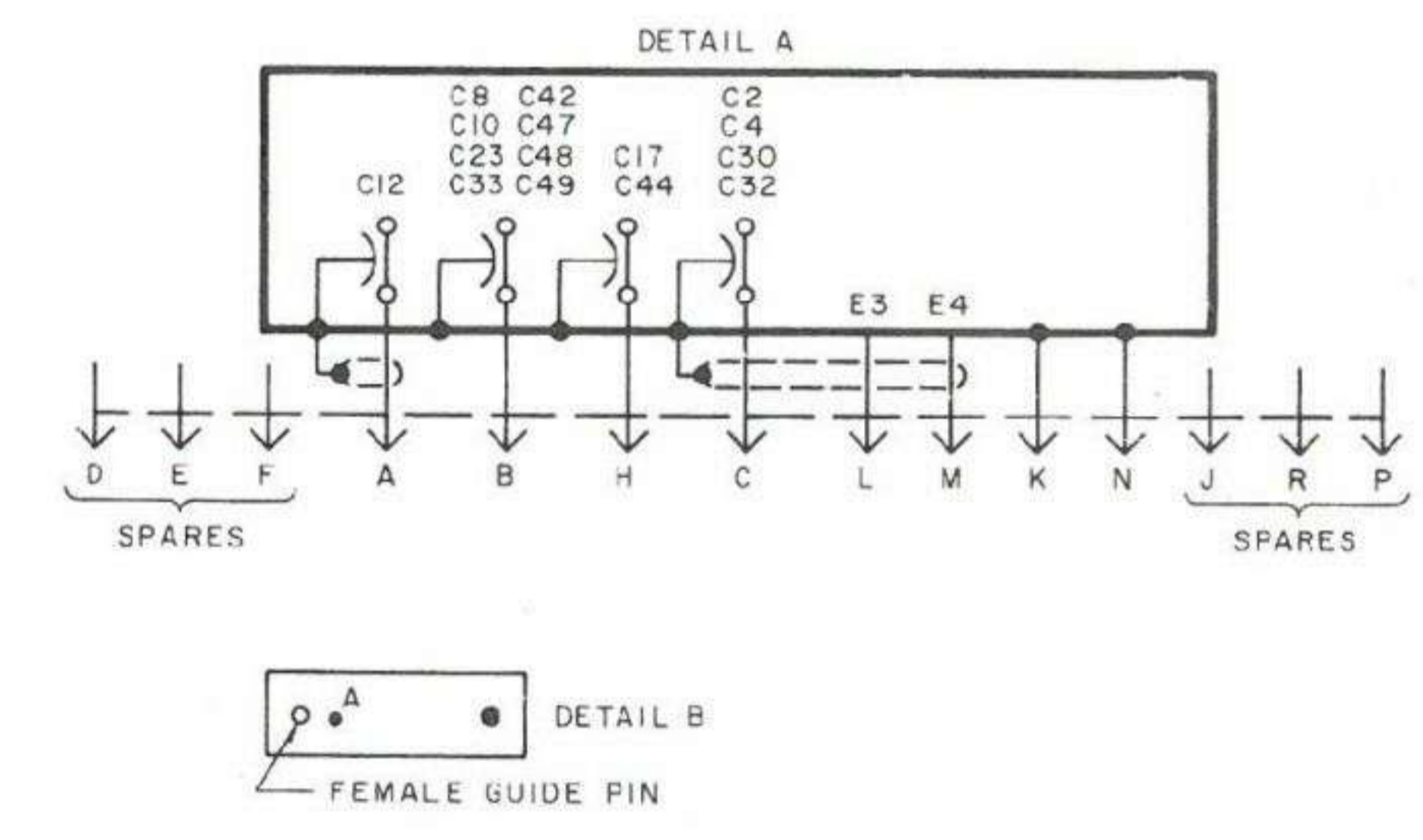

Change 1 3/17/75

Figure 6-1. Type 71281 100-180 MHz Tuner (A1), Schematic Diagram

Figure 6-2



R4	12.1K	R35	39.2K
R6	18.2K	R36	8.06K
R7	68.1K	R38	5.36K
R24	68.1K	R39	75K
R25	86.6K	R40	36.5K
R26	12.1K	R41	6.81K
R28	1.50K	R43	7.15K
R29	75K	R44	100K
R30	56.2K	R45	30.1K
R31	9.09K	R46	5.11K
R33	4.12K	R48	9.09K
R34	68.1K	R15	330

- NOTES:
- UNLESS OTHERWISE SPECIFIED:
 a) RESISTANCE IS MEASURED IN OHMS, $\pm 5\%$, 1/4 W.
 b) CAPACITANCE IS MEASURED IN μF .
 - ENCIRCLED NUMBERS ARE MODULE PIN NUMBERS.
 - CW ON POTENTIOMETERS DENOTE CLOCKWISE ROTATION OF ACTUATOR.
 - FOR U1, U2 PIN ARRANGEMENT, SEE DETAIL A.
 - DIFFERENCE BETWEEN TYPES IS SHOWN IN TABULATION BLOCK. ALL VALUES ARE NOMINAL; FINAL VALUES TO BE FACTORY SELECTED. ALL RESISTANCES IN TABULATION BLOCK ARE IN OHMS, $\pm 1\%$, 1/4 W.
 - SHAPING AMPLIFIERS WITH PREVIOUSLY ASSIGNED TYPE NUMBERS ARE LISTED BELOW WITH THEIR CORRESPONDING 79844 SERIES NUMBER. THESE OLD TYPE NUMBERS ARE LISTED FOR REFERENCE ONLY.

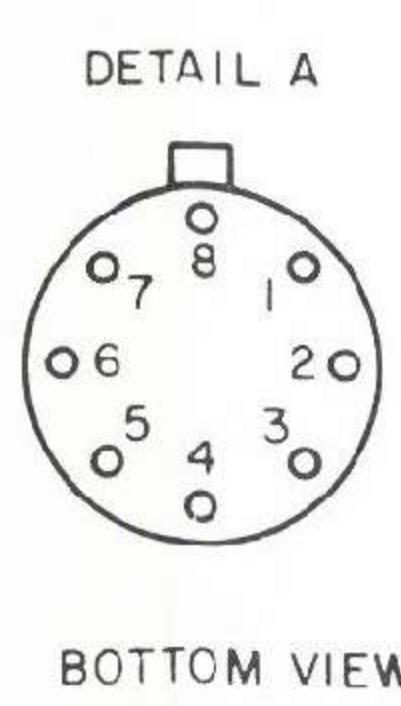

TUNING HEAD	OLD TYPE	79844-
VH-11	79618	-7
VH-12	79655	-2
VH-13	79656	-3
VH-14	79658	-4
VH-16	79844	-1
UH-11	79871	-5

Change 1 3/17/75

Figure 6-2. Type 79844-3 Shaping Amplifier (A2), Schematic Diagram

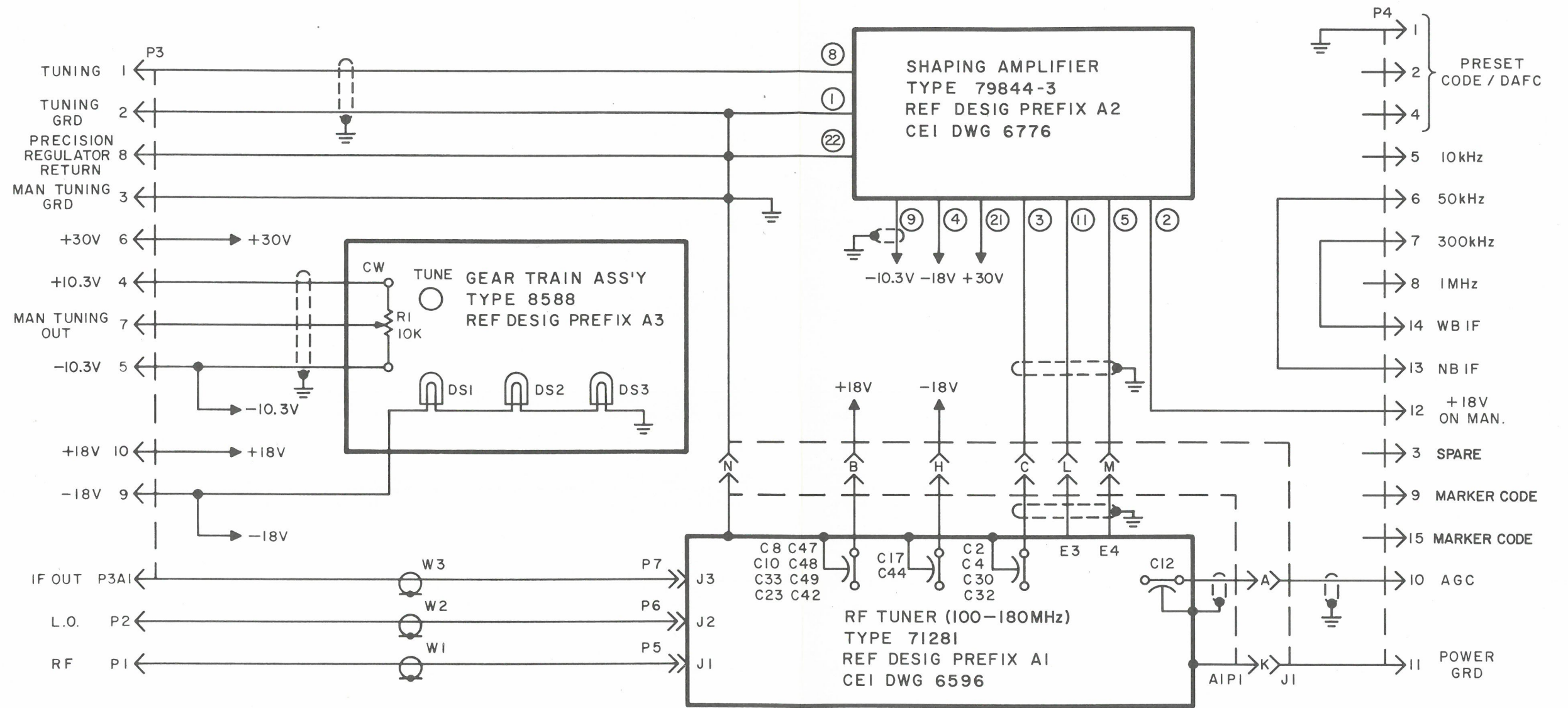

- NOTES:
1. ENCIRCLED NUMBERS ARE MODULE PIN NUMBERS.
 2. FOLLOWING NOTATIONS ARE USED ON POTENTIOMETERS:
 - a) CW INDICATES CLOCKWISE ROTATION OF CONTROL KNOB.
 - b) ○ INDICATES FRONT PANEL CONTROL.

Change 1 3/17/75

Figure 6-3. Type VH-13 Tuning Head. Main Chassis Schematic Diagram

