

198.50

100

# WJ-8888 RECEIVER



## FEATURES

The WJ-8888 is a highly versatile HF receiver which provides exceptional signal handling capabilities over the frequency range of 500 kHz to 30 MHz. The receiver has three operating modes: Local, Remote and Memory. In the Local mode, the receiver is tuned manually by the operator. In the Remote mode, the receiver accepts and stores a digital word which controls the tuned frequency, detection mode, gain mode, IF bandwidth, RF gain level and BFO frequency. In conjunction with the Local mode, the Memory mode enables the operator to store up to sixteen sets of receiver frequencies and control parameters which may be recalled as required.

The receiver is designed for the reception of AM, FM, CW, ISB, LSB and USB emissions. Up to six IF bandwidths may be selected via front panel push-button switches. Four standard IF bandwidths of 0.5, 2, 4 and 8 kHz are supplied with two IF bandwidths reserved for customer selection. The optional IF bandwidths are 0.2, 1, 3, 6, 12 or 16 kHz.

Additional features of the WJ-8888 include a unique manual tuning control where

the tuning rate varies in proportion to the rotational speed of the tuning control knob. The tuning knob and its associated circuitry provides the operator with the utmost in tuning accuracy. At slow rotational speeds, the operator can easily select increments as small as 10 Hz to facilitate the handling of narrowband signals. At higher rotational speeds, bandedge-to-bandedge tuning can be accomplished in a quick, efficient manner. Other features include automatic switching of sub-octave preselection filters to minimize intermodulation distortion and a synthesized local oscillator for maximum receiver stability.

The tuned frequency of the receiver is displayed on a front panel seven-digit LED readout. Resolution of the display is 10 Hz over the entire tuning range. Three selectable gain control modes are provided: Manual, Normal AGC, and Hold AGC. A meter on the front panel indicates relative signal strength or calibrated line audio output level. Front panel controls include: Main Tuning, RCVR Control, IF Bandwidth Select, Gain Mode

For Further Information Please Contact:

### WATKINS-JOHNSON COMPANY

700 Quince Orchard, Gaithersburg, Maryland 20760  
(301)948-7550, TWX 710-828-0546 TELEX 89-8402

JUNE 1974

Select, Detection Mode Select, RF Gain, ISB Audio Select, Audio Level, Squelch, and Variable BFO Control.

Variable audio output is available at a front panel phone jack and balanced LSB, USB, and Line Audio Outputs as well as the variable audio is available at a rear panel connector. An audio squelch circuit mutes the receiver audio output in the absence of incoming signals below the threshold set by the front panel Squelch Control. The receiver also provides a predetection IF output and a Signal Monitor output with a center frequency of 455 kHz. The 64-bit TTL-compatible I/O data is interfaced to the unit via connectors on the rear panel.

To enhance the receiver's versatility, a number of options are available in addition to the customer selected bandwidth options. The receiver may be ordered without the preselection sub-octave filters when the receiver is used in a low signal density environment or

when preselection is accomplished by the associated antenna network.

An optional logarithmic IF amplifier is available to provide a log video output to a rear panel BNC connector. The standard I/O interface module accepts a standard 64-bit serial synchronous data word. As a customer selected option, transmission of the 64-bit data word can be serial or parallel, synchronous or asynchronous. In systems where master/slave or remote operation of receiver groups is desired, the remote/slave receivers can be supplied without front panel control and frequency readout.

The WJ-8888 is designed for mounting in a standard 19-inch equipment rack and occupies 5.25 inches of vertical space. The standard unit operates on 115/220 Vac  $\pm 10\%$ , 48-62 Hz. An optional model is available for operation from a 400 Hz, 115/220 Vac prime power source.

## SPECIFICATIONS

Tuning Range . . . . .	0.5 - 30 MHz
Preselection . . . . .	Sub-octave filters automatically switched
Input Impedance . . . . .	50 ohms, unbalanced
Input V.S.W.R. . . . .	2.5:1, maximum
Oscillator Radiation . . . . .	10 $\mu$ V or less at receiver input
Noise Figure . . . . .	15 dB, maximum
IF Bandwidths, (3 dB) . . . . .	4 Bandwidths supplied, 6 positions available
Normally supplied . . . . .	0.5, 2, 4 and 8 kHz
Optional . . . . .	0.2, 1, 3, 6, 12 or 16 kHz
Detection Modes . . . . .	AM Noise Limiter, AM, CW fixed, CW variable USB, LSB, ISB, FM
Gain Control Modes . . . . .	Manual, Normal AGC, Hold AGC
AGC and Manual Range . . . . .	100 dB, minimum, for input signals above 2 $\mu$ V
AGC Threshold . . . . .	2.0 $\mu$ V, minimum
AGC Attack Time . . . . .	20 ms
AGC Release Time . . . . .	Normal AGC, 0.1 seconds; Hold AGC, 2 seconds
Control Modes . . . . .	Local, Memory and Remote
Sensitivity	
AM Sensitivity . . . . .	The input signal levels specified in Table 1, 50% AM modulated at 400 Hz rate will produce a 10 dB (S+N)/N ratio at the audio output.
CW Sensitivity . . . . .	The CW input signal levels specified in Table 1, will produce a 16 dB (S+N)/N ratio at the audio output.
FM Sensitivity . . . . .	The input signal levels specified in Table 1, FM modulated at a deviation equal to 30% of the IF bandwidth, at a rate equal to 10% of the IF bandwidth or 400 Hz, whichever is less, will produce a 17 dB (S+N)/N ratio at the audio output.
LSB, USB, ISB . . . . .	0.50 $\mu$ V for 10 dB (S+N)/N or greater in 2.8 kHz bandwidth.
Outputs	
Line Audio . . . . .	1 mW, minimum, transformer coupled, balanced, into 600 ohms at the specified sensitivity levels
Audio Distortion . . . . .	Less than 5%
Audio Amplifier Frequency Response . . . . .	Within 3 dB from 100 Hz to 15 kHz

Phones . . . . .	10 mW, minimum, into 600 Ω front panel adjusted
ISB (LSB, USB) . . . . .	Two, each provides 1 mW, minimum, transformer coupled, balanced, into 600 Ω at 0.5 μV input level
IF . . . . .	455 kHz, 50 mV, minimum, at the above sensitivity levels
Signal Monitor . . . . .	455 kHz center frequency, bandwidth limited by first IF filter
IF Rejection . . . . .	Greater than 100 dB
Image Rejection . . . . .	Greater than 100 dB
Unwanted Sideband Rejection . . . . .	50 dB at 350 Hz into unwanted sideband
Intermodulation	
Third Order Input Intercept Point . . . . .	+20 dBm, min. for signal separation 50 kHz
Second Order Input Intercept Point . . . . .	+60 dBm, minimum
Cross Modulation . . . . .	With desired signal at 50 μV, an undesired signal at 50 mV greater than 50 kHz away, AM modulated 30% produces an output at least 20 dB below the output level of desired signal.
Tuning Speed (Remote) . . . . .	5 mSec minimum to 15 mSec maximum, including VCO and IF filter settling time
Manual Tuning . . . . .	Variable rate, depending on rotation speed of tuning knob. Rate is linear at low rotational speeds and logarithmic above one revolution per second. The minimum tuning increment is 10 Hz.
Frequency Selection (Local) . . . . .	Single tuning knob
Frequency Stability . . . . .	6 x 10 <sup>-8</sup> per day, 2 x 10 <sup>-6</sup> per year
Frequency Display . . . . .	7 Digit, LED (dot matrix) display
Remote Control . . . . .	Via Input/Output TTL serial synchronous differential pair, 64-bit word; format as shown below:

DATA WORD FORMAT

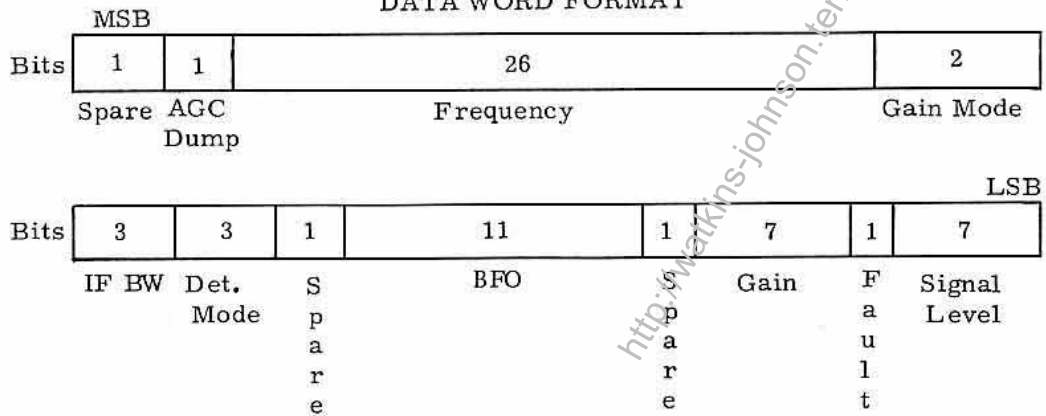

Remote Control Interface:	
Input Trigger . . . . .	Differential pair, TTL strobe pulse, positive logic, 5 ms minimum pulse width; from controlling device to command receiver to supply clock signal for synchronous transfer of data
Clock Output . . . . .	Differential pair, TTL clock train, 250 kHz, 10% duty cycle square wave; effects serial data transfer to/from controller
Receiver Address . . . . .	One differential pair, discrete, TTL level Logic 1 = receiver addressed Logic 0 = receiver not addressed
Memory Mode . . . . .	Four channel memory capacity supplied. The entire 64-bit word is stored. Complete operating mode of the receiver may be internally stored and recalled later.

Optional Memory . . . . .

AC Power Interrupt . . . . .

Non-Remote Control Functions . . . . .

Signal Meter . . . . .

Size . . . . .

Weight . . . . .

Operating Temperature . . . . .

Power Consumption . . . . .

Input Power Requirements . . . . .

Up to a total of sixteen channels in groups of four channels.

While the receiver is in the Local Mode, all the above functions are placed in a separate memory and reappear when power returns.

Phone level, squelch, memory channel select and RF/Audio meter

Indicates RF input signal level or line audio output level

16 inches wide or 19 inches wide, 5-1/4 inches high and 16 inches deep

Approximately 40 pounds

0° - 50° C (32° F to 122° F)

Approximately 80 watts

115/220 Vac ± 10%, 48-62 Hz, 400 Hz operation available as an option.

TABLE 1  
SENSITIVITY

IF Bandwidth kHz	Input Level	
	Microvolts	dBm
0.2	0.28	-118
0.5	0.45	-114
1.0	0.64	-111
2.0	0.89	-108
3.0	1.2	-105.5
4.0	1.3	-105
6.0	1.7	-102.5
8.0	1.8	-102
12.0	2.4	-99.5
16.0	2.5	-99

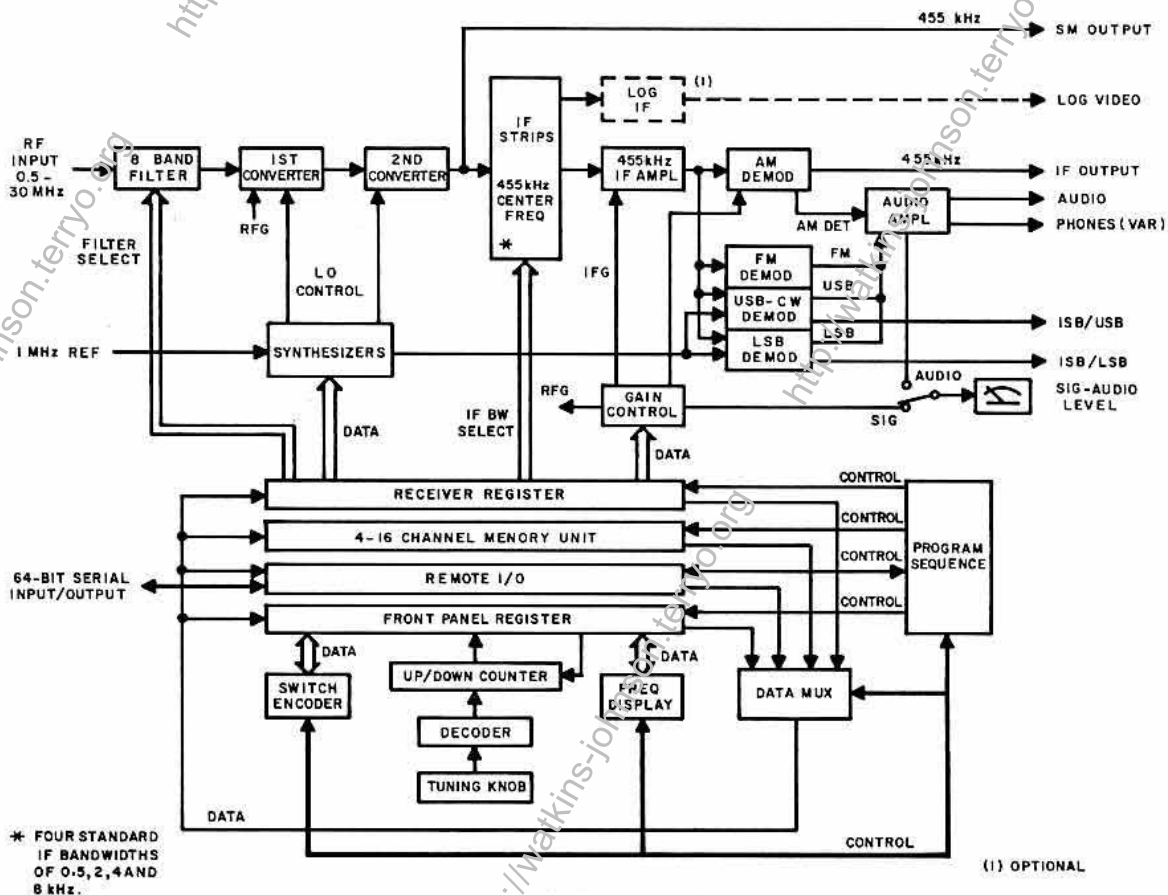

WJ-8888 RECEIVER-SIMPLIFIED BLOCK DIAGRAM

(1) OPTIONAL