

May 1997

## Correlative-vector DF Processor WJ-8996-1



The WJ-8996-1 represents the next generation in light-weight, manportable Direction Finding (DF) processors. State-of-the-art design and manufacturing techniques combine to yield a low power, light-weight unit with extraordinary capabilities. The processor contains four complete RF channels to allow modulation-independent acquisition of short duration signals. A correlative-vector DF algorithm is implemented that offers improved performance and antenna flexibility. Previously, such algorithms were only available on much larger systems.

WJ designed the WJ-8996-1 primarily for manportable missions. The mechanical design minimizes weight while maintaining durability.

The WJ-8996-1 functions as a core DF processor. Although the basic unit does not contain a front panel, front-panel operation is easy via a laptop computer or handheld controller.

The unit is extremely reliable and easily maintained. A built-in calibration source constantly monitors the response of the four channels and implements the needed corrections. Also an extensive Built-in Test (BIT) capability notifies the operator or remote host of any detected fault. The fundamental construction of the WJ-8996-1 makes it easy to maintain and service.

### Features

- Lightweight/lowpower*
- 20 to 2000 MHz frequency range (tunable to 0.5 MHz)*
- Correlative-vector DF technique for high accuracy/antennaversatility*
- 4 independent RF channels*
- Ruggedization to MIL-STD-810C*
- DSP technology to obtain high processing gain/DF sensitivity*
- RS-232 interface*
- Signal intercept & acquisition capabilities*
- Capability for netted operations*
- CE certification*

<b>HEIGHT</b>	3.5in.(8.89cm)	<b>DEPTH*</b>	16in.(40.64cm)
<b>WIDTH</b>	8.5in.(21.59cm)	<b>WEIGHT**</b>	13lbs(5.89kg)

\*with battery cover  
\*\*not including battery

#### WATKINS-JOHNSON COMPANY

700 Quince Orchard Road, Gaithersburg, Maryland 20878-1794  
Phone: (800) WJHELPS or +(301) 948-7550  
FAX: +(301) 921-9479 Email: wj.helps@wj.com Website: www.wj.com

**All International sales of WJ equipment are subject to USA export license approval. This material provides up-to-date general information on product performance and use. It is not contractual in nature, nor does it provide warranty of any kind.**

## Functional Description

The WJ-8996-1 DF Processor uses one of the most accurate and versatile DF techniques available. This technique is based on the ability to learn the response of the DF antenna array to received signals over all angles and frequencies. This response is referred to as the database, or the manifold of the antenna array. For each antenna element, a complex voltage vector describes the amplitude and phase of that element. Once the database is accurately established, a Line-of-Bearing (LOB) on a received signal is calculated by measuring the voltage vectors and comparing, or correlating, these vectors to those contained in the database. The point at which the best match or correlation is achieved is taken as the LOB. This DF technique is referred to as Correlative Vector DF.

The Correlative-vector DF technique permits the use of a large range of DF antennas. The WJ-8996-1 processor works with various WJ manportable antenna arrays such as the WJ-9881-X series, the WJ-9887 low-profile series, and the WJ-9896 HF monopole array. In addition, the unit is easily integrated with customer-supplied antenna arrays or DF antennas from other vendors. A user can also configure up to a total of four WJ-8996-1 units into a single network. The operator can use LOB data from the outstations to calculate a fix on transmitter positions.

The following figure shows a functional block diagram of the WJ-8996-1. The unit consists of three primary sections: RF Assembly, DC/DC Options Board, and Digital Board.

The RF Assembly houses four complete RF front ends. These *RF Channels* simultaneously sample the outputs from up to four antenna elements. This information is digitized and used in the DF algorithms. The Local Oscillators (LOs) are coherently split between the RF channels. Direct Digital Synthesis technology improves tuning speed and resolution. A Calibration Channel permits real time calibration of the amplitude and phase differences between the RF Channels. This calibration is accomplished by injecting the same calibration signal at the antenna outputs, and measuring the differences between the channels.

The Digital Board contains the Digital Signal Processing (DSP) Processor (TMS320C31) and the Control Processor (MC68340FE). The operational tasks of the WJ-8996-1 are divided among the various processors in an optimal fashion. The Control Processor manages the overall operation of the unit while the DSP Processor performs the majority of the signal processing functions. The board also contains hardware necessary for netting operations.

The DC/DC Options Board contains the power supplies and associated filtering. In addition, this board contains demodulation circuitry for AM, FM, CW, LSB, and USB detection modes.

## Options and Future Enhancements

The fundamental WJ-8996-1 design easily incorporates a variety of upgrades to increase capabilities and performance. See WJ-8991/SYS data sheet for details of options available. For detailed specifications, contact the factory.

Specifications

<b>SYSTEM (DF processor with typical antenna)</b>	
Frequency Range .....	20 to 1200 MHz
Accuracy .....	2 to 5° rms (antenna & site dependent; 3° rms, typical)
Sensitivity .....	<10 mV/m, typical
Power Consumption .....	<20 W, typical
<b>PROCESSOR</b>	
Frequency Range .....	20 to 2000 MHz (Tuning allowed to 0.5 MHz)
Tuning Resolution .....	100 Hz, synthesized
Demodulation .....	AM, FM, CW, USB, LSB
Internal Reference Accuracy .....	±5 parts in 10 <sup>-6</sup> (0 to 50°C)
Input VSWR .....	2.0:1, typical
Noise Figure .....	16 dB (20 to 1200 MHz) max 17 dB (>1200 MHz) max
3rd-order Intercept Point .....	-20 dBm
Dynamic Range .....	110 dB
Sampling Rate .....	100 kHz (12 bits)
Instantaneous Dynamic Range .....	60 dB, typical
Internally Generated Spurious .....	< -100 dBm equivalent input, typical
Power Source .....	11 to 36 Vdc (designed for battery operations)
Battery .....	BA-5590/U
Control Processor .....	MC68340
DSP Processor .....	TMS320C31
Digital Bandwidths (kHz) .....	25, 12.5, 6.25, 3.125, 1.563, 0.781, 0.391, 0.195
Operating Temperature .....	-20 to +60°C
Storage Temperature .....	-40 to +70°C
Shock & Vibration .....	Designed to MIL-STD-810C
Humidity .....	95% RH, noncondensing

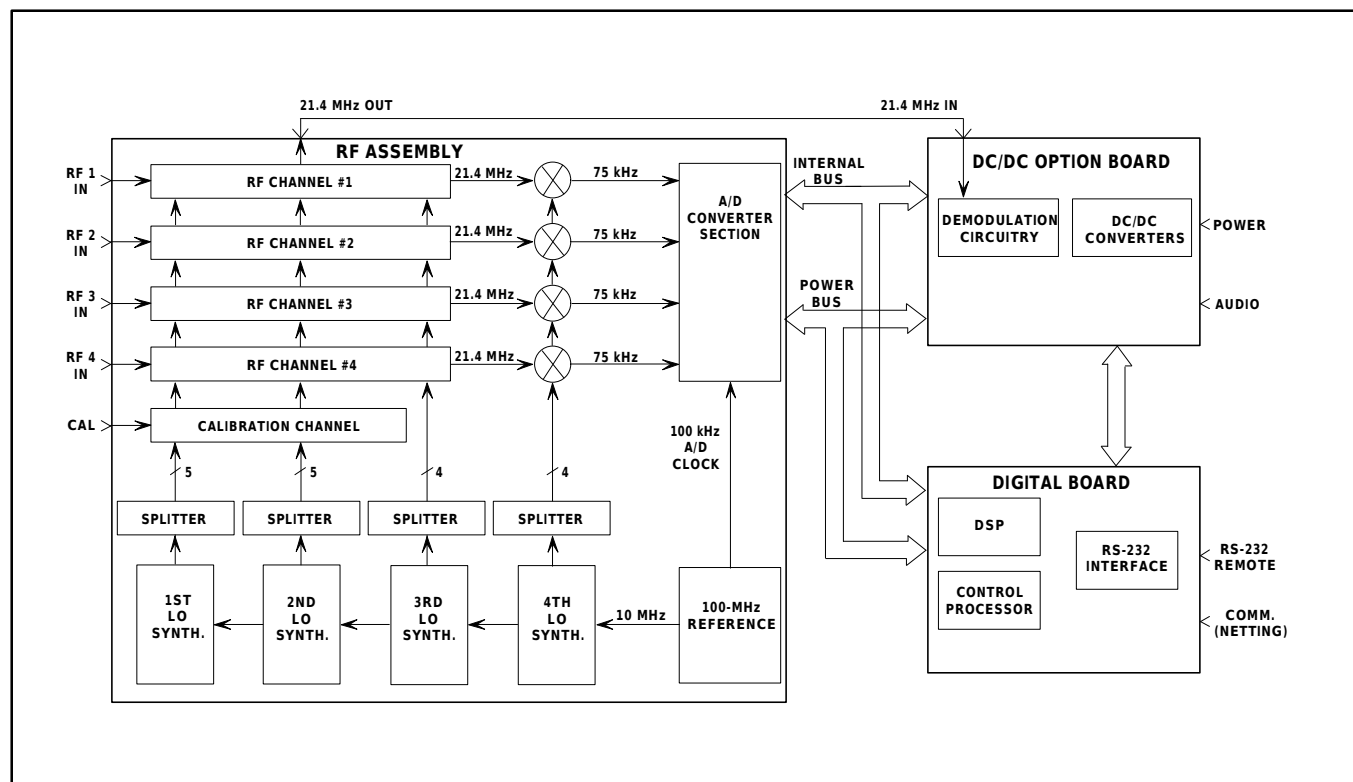

WJ-8996-1 Functional Block Description

## Front-panel Connectors

Connector	Reference Designator	Description
<b>CHAN 1</b> <b>CHAN 2</b> <b>CHAN 3</b> <b>CHAN 4</b> <b>CAL</b> <b>POWER</b>	<b>J1</b> <b>J2</b> <b>J3</b> <b>J4</b> <b>J5</b> <b>J6</b>	<b>Channel 1 input from DF element 1. BNC-50W</b> <b>Channel 2 input from DF element 2. BNC-50W</b> <b>Channel 3 input from DF element 3. BNC-50W</b> <b>Channel 4 input from DF element 4. BNC-50W</b> <b>Calibration signal output. BNC-50W</b> <b>Power input. 6-pin environmental connector - JTL07RE-10-98P</b> <b>1 - GND</b> <b>2 - +V</b> <b>3 - +BATT</b> <b>4 - GND</b> <b>5 - +CHARGE</b> <b>6 - -CHARGE</b>
<b>REMOTE</b>  <b>EXTERNAL/CONTROL</b>	<b>J7</b>  <b>J8</b>	<b>2 RS-232 serial interfaces - JTL07RE-10-13S</b> <b>Antenna control outputs &amp; external control inputs - JTL07RE-10-13S</b> <b>1 - CAL</b> <b>2 - Antenna Control C3</b> <b>3 - Antenna Control C2</b> <b>4 - Antenna Control C1</b> <b>5 - Antenna Control C0</b> <b>6 - GND</b> <b>7 - +5V</b> <b>8 - -5V</b> <b>9 - Reserved</b> <b>10 - Reserved</b> <b>11 - Reserved</b> <b>12 - Reserved</b> <b>13 - Reserved</b>
<b>AUDIO</b>	<b>J9</b>	<b>Audio output - GC283</b> <b>A - GND</b> <b>B - Output</b> <b>C - Push to Talk (PTT)</b> <b>D - Input</b> <b>E - Not used</b> <b>F - Not used</b>
<b>COMM</b>	<b>J10</b>	<b>Communications port - GC283</b> <b>A - GND</b> <b>B - Input</b> <b>C - Push to Talk (PTT)</b> <b>D - Output</b> <b>E - Not used</b> <b>F - Not used</b>